

# *Programming*

# *Manual*

*Table of Contents*

**1) Chapter One ..... 12**

- Basic Assembly Language Programming Concepts..... 12**
- Binary Numbers ..... 12
- Grouping Bits into Bytes..... 13
- Hexadecimal Representation of Binary ..... 14
- The ACSII Character Set ..... 15
- Boolean Logic..... 16
  - Logical And ..... 16
  - Logical Or ..... 17
  - Logical Exclusive Or..... 17
  - Logical Complement..... 17
- Signed Numbers ..... 18
- Storing Numbers in Decimal Form ..... 19
- Computer Arithmetic..... 20
- Microprocessor Programming..... 20
  - Machine Language..... 20
  - Assembly Language..... 22
- Writing in Assembly Language ..... 22
- Basic Programming Concepts..... 23
  - Selection Between Paths..... 24
  - Looping ..... 24
  - Subroutines ..... 24

**2) Chapter Two ..... 26**

- Architecture of the 6502 ..... 26**
- Microprocessor Architecture ..... 26
- The 6502 Registers ..... 26
  - The Accumulator ..... 27
  - The X and Y Index Registers..... 29
  - The Status Register ..... 29
  - Abbrev ..... 30
  - Name ..... 31
  - The Stack Pointer..... 31
  - The Program Counter ..... 33
- Addressing Modes ..... 33
- Instructions ..... 35
- The 6502 System Design..... 38
  - Pipelining ..... 38
  - Memory Order of Multiple-Byte Values ..... 39
  - Memory-Mapped Input/Output..... 39
  - Interrupts ..... 39
- NMOS Process ..... 40
- Bugs and Quirks ..... 40

**3) Chapter Three ..... 41**

- Architecture of the 65C02 ..... 41**
- The 65C02 Architecture..... 41
- Addressing Modes ..... 41
- Instructions ..... 42
- CMOS Process ..... 42
- Bugs and Quirks ..... 42

**4) Chapter Four..... 44**

- Sixteen-Bit Architecture The 65816 and the 65802..... 44**

<b>The Western Design Center</b>	
<b>Power-On Status: 6502 Emulation Mode</b> .....	<b>45</b>
<b>The Full-Featured 65x Processor: The 65816 in Native Mode</b> .....	<b>45</b>
The Program Bank Register .....	47
The Data Bank Register .....	48
The Direct Page Register .....	48
The Stack Pointer.....	48
Accumulator and Index Registers .....	48
Switching Registers Between Eight and Sixteen Bits.....	50
The Status Register .....	50
6502/65C02 Addressing Modes on the 65816.....	51
New 65816 Addressing Modes .....	52
Instructions .....	54
Interrupts.....	55
<b>The 65802 Native Mode</b> .....	<b>55</b>
Emulation Mode.....	58
Emulation Mode Registers.....	60
<b>Switching Between 6502 Emulation and Native Modes</b> .....	<b>61</b>
Switching from Emulation to Native Mode .....	61
Switching from Native to Emulation Mode .....	61
<b>65802/65816 Bugs and Quirks</b> .....	<b>62</b>
<b>5) Chapter Five</b> .....	<b>64</b>
<b>SEP, REP, and Other Details</b> .....	<b>64</b>
The Assembler Used in This Book .....	66
Address Notation.....	68
<b>6) Chapter Six</b> .....	<b>69</b>
<b>First Examples: Moving Data</b> .....	<b>69</b>
<b>Loading and Storing Registers</b> .....	71
Effect of Load and Store Operations on Status Flags.....	73
Moving Data Using the Stack.....	73
Push.....	74
Pushing the Basic 65x Registers .....	76
Pull.....	76
Pulling the Basic 65x Registers .....	76
Pushing and Pulling the 65816's Additional Registers.....	78
Pushing Effective Addresses.....	79
Other Attributes of Push and Pull .....	79
<b>Moving Data Between Registers</b> .....	79
Transfers.....	79
Exchanges.....	86
<b>Storing Zero to Memory</b> .....	86
Block Moves .....	87
<b>7) Chapter Seven</b> .....	<b>89</b>
<b>Simple Addressing Modes</b> .....	<b>89</b>
Immediate Addressing .....	90
Absolute Addressing .....	92
Direct Page Addressing.....	94
Indexing.....	95
Absolute Indexed with X and Absolute Indexed with Y Addressing .....	98
Direct Page Indexed with X and Direct Page Indexed with Y Addressing .....	101
Accumulator Addressing .....	103
Implied Addressing.....	103
Stack.....	104
Direct Page Indirect Addressing.....	104
Absolute Long Addressing.....	105

<b>The Western Design Center</b>	
<b>Absolute Long Indexed with X Addressing</b> .....	108
<b>Direct Page Indirect Long</b> .....	109
<b>Block Move</b> .....	110
<b>8) Chapter Eight</b> .....	<b>111</b>
<b>The Flow of Control</b> .....	<b>111</b>
<b>Jump Instructions</b> .....	112
<b>Conditional Branching</b> .....	114
Branching Based on the Zero Flag.....	115
Branching Based on the Carry Flag.....	117
Branching Based on the Negative Flag.....	118
Branching Based on the Overflow Flag.....	119
Limitations of Conditional Branches.....	119
<b>Unconditional Branching</b> .....	119
<b>9) Chapter Nine</b> .....	<b>122</b>
<b>Built-In Arithmetic Functions</b> .....	<b>122</b>
<b>Description</b> .....	<b>122</b>
<b>Increment and Decrement</b> .....	123
<b>Addition and Subtraction: Unsigned Arithmetic</b> .....	127
<b>Comparison</b> .....	130
<b>Signed Arithmetic</b> .....	134
<b>Signed Comparisons</b> .....	136
<b>Decimal Mode</b> .....	137
<b>10) Chapter Ten</b> .....	<b>139</b>
<b>Logic and Bit Manipulation Operations</b> .....	<b>139</b>
<b>Logic Functions</b> .....	139
Logical AND.....	140
Logical OR.....	142
Logical Exclusive-Or.....	143
<b>Bit Manipulation</b> .....	145
<b>Shifts and Rotates</b> .....	146
<b>11) Chapter Eleven</b> .....	<b>154</b>
<b>The Complex Addressing Modes</b> .....	<b>154</b>
Relocating the Direct Page.....	155
Assembler Addressing Mode Assumptions.....	156
Direct Page Indirect Indexed With Y Addressing.....	158
Direct Page Indexing Indirect Addressing.....	161
Absolute Indexed Indirect Addressing.....	163
Direct Page Indirect Long Indexed with Y Addressing.....	165
Stack Relative Addressing.....	166
Stack Relative Indirect Indexed Addressing.....	168
Push Effective Instructions.....	169
<b>12) Chapter Twelve</b> .....	<b>174</b>
<b>The Basic Building Block:</b> .....	<b>174</b>
The Subroutine.....	174
The Jump-To-Subroutine Instruction.....	175
The Return-from-Subroutine Instruction.....	175
JRS Using Absolute Indexed Indirect Addressing.....	177
The Long Jump to Subroutine.....	178
Return from Subroutine Long.....	178
Branch to Subroutine.....	179
Coding a Subroutine: How and When.....	180
6502 Eight-Bit Negation – A Library Example.....	180
65C02, 65802, and 65816 Eight-Bit Negation.....	181

<b>The Western Design Center</b>	
6502 Sixteen-Bit Negation .....	181
65802 and 65816 Sixteen-Bit Negation.....	181
<b>Parameter Passing</b> .....	182
<b>13) Chapter Thirteen</b> .....	<b>192</b>
<b>Interrupts and System Control Instructions</b> .....	<b>192</b>
<b>Interrupts</b> .....	192
Processing Interrupts .....	197
Interrupt Response Time .....	200
<b>Status Register Control Instruction</b> .....	201
<b>No Operation Instructions</b> .....	202
<b>14) Chapter Fourteen</b> .....	<b>204</b>
<b>Selected Code Samples</b> .....	<b>204</b>
<b>Multiplication</b> .....	204
6502 Multiplication.....	205
65C02 Multiplication .....	205
65802 and 65816 Multiplication .....	205
<b>Division</b> .....	208
6502 Division .....	209
65C02 Division.....	211
65802/65816 Division .....	211
<b>Calling an Arbitrary 6502 Routine</b> .....	213
<b>Testing Processor Type</b> .....	219
<b>Compiler-Generated 65816 Code for a RecursiveProgram</b> .....	220
The Same Example Hand-Coded in Assembly Language .....	224
<b>The Sieve of Eratosthenes Benchmark</b> .....	226
<b>15) Chapter Fifteen</b> .....	<b>230</b>
<b>DEGUG16 – A 65816 Programming Tool</b> .....	<b>230</b>
<b>Declarations</b> .....	232
<b>LIST</b> .....	234
<b>FLIST</b> .....	236
<b>FRMOPRND</b> .....	238
<b>POB</b> .....	243
<b>STEP</b> .....	244
<b>PUTHEX</b> .....	246
<b>CLRLN</b> .....	248
<b>UPDATE</b> .....	249
<b>PRINTLN</b> .....	251
<b>TRACE</b> .....	252
<b>EBRKIN</b> .....	254
<b>CHKSPCL</b> .....	259
<b>DUMPREGS</b> .....	263
<b>PUTRTEG8</b> .....	265
<b>TABLES</b> .....	266
<b>16) Chapter Sixteen</b> .....	<b>276</b>
<b>Design and Debugging</b> .....	<b>276</b>
<b>Debugging Checklist</b> .....	276
Decimal Flag .....	276
Adjusting Carry Prior to Add / Subtract .....	276
65x Left-to-Right Syntax.....	276
65x Branches .....	277
6502 Jump Bug.....	277
Interrupt-Handling Code.....	277
65802/65816: Emulation Versus Native Mode .....	277
65802/65816: Eight-Bit Versus Sixteen-Bit Registers .....	278
65802/65816: The Direct Page .....	278

<b>The Western Design Center</b>	
65802/65816: Stack Overruns Program or Data .....	278
65802/65816: JSR/JSL and RTS/RTL.....	278
65802/65816: MVN/MVP .....	278
Return Address .....	279
Inconsistent Assembler Syntax .....	279
<b>Generic Bugs: They Can Happen Anywhere.....</b>	<b>279</b>
Uninitialized Variables .....	279
Missing Code .....	279
Failure to Increment the Index in a Loop.....	279
Failure to Clean Up Stack.....	280
Immediate Data Versus Memory Location.....	280
Initializing the Stack Pointer from a Subroutine .....	280
<b>Top-Down Design and Structured Programming .....</b>	<b>280</b>
<b>Documentation .....</b>	<b>281</b>

**17) Chapter Seventeen..... 283**

<b>The Addressing Modes .....</b>	<b>283</b>
Absolute Addressing .....	288
Absolute Indexed, X Addressing .....	289
Absolute Indexed, Y Addressing .....	290
Absolute Indexed Indirect Addressing .....	291
Absolute Indirect Addressing .....	292
Absolute Indirect Long Addressing .....	293
JMP [addr].....	293
Absolute Long Addressing .....	294
Absolute Long Indexed, X Addressing .....	295
Accumulator Addressing.....	296
Block Move Addressing .....	297
Direct Page Addressing .....	298
Direct Page Indexed, X Addressing .....	299
Direct Page Indexed, Y Addressing .....	300
Direct Page Indexed Indirect, X Addressing.....	301
Direct Page Indirect Addressing .....	302
Direct Page Indirect Long Addressing .....	303
Direct Page Indirect Indexed, Y Addressing.....	304
Direct Page Indirect Long Indexed, Y Addressing.....	305
Immediate Addressing.....	306
Implied Addressing .....	307
Program Counter Relative Addressing.....	308
Program Counter Relative Long Address .....	309
Stack (Absolute) Addressing .....	310
Stack (Direct Page Indirect) Addressing .....	312
Stack (Interrupt) Addressing.....	314
Stack (Program Counter Relative) Addressing .....	316
Stack (Pull) Addressing .....	317
Stack (Push) Addressing.....	319
Stack (RTI) Addressing.....	321
Stack (RTL) Addressing.....	322
Stack (RTS) Addressing .....	323
Stack Relative Addressing.....	324
Stack Relative Indirect Indexed, Y Addressing .....	325

**18) Chapter Eighteen..... 326**

<b>The Instruction Sets.....</b>	<b>326</b>
<b>Add With Carry.....</b>	<b>327</b>
Opcode .....	327
Bytes.....	327
Cycles.....	327
<b>And Accumulator with Memory.....</b>	<b>328</b>
Second.....	328

## The Western Design Center

Operand.....	328
<b>Shift Memory or Accumulator Left.....</b>	<b>329</b>
<b>Branch if Carry Clear.....</b>	<b>330</b>
<b>Branch if Carry Set.....</b>	<b>331</b>
<b>Branch if Equal.....</b>	<b>332</b>
<b>Test Memory Bits against Accumulator.....</b>	<b>333</b>
<b>Branch if Minus.....</b>	<b>334</b>
<b>Branch if Not Equal.....</b>	<b>335</b>
<b>Branch if Plus.....</b>	<b>336</b>
<b>Branch Always.....</b>	<b>337</b>
<b>Software Break.....</b>	<b>338</b>
<b>Branch Always Long.....</b>	<b>340</b>
<b>Branch if Overflow Clear.....</b>	<b>341</b>
<b>Branch if Overflow Set.....</b>	<b>342</b>
<b>Clear Carry Flag.....</b>	<b>343</b>
<b>Clear Decimal Mode Flag.....</b>	<b>344</b>
<b>Clear Interrupt Disable Flag.....</b>	<b>345</b>
<b>Clear Overflow Flag.....</b>	<b>346</b>
<b>Compare Accumulator with Memory.....</b>	<b>347</b>
<b>Co-Processor Enable.....</b>	<b>349</b>
<b>Compare Index Register X with Memory.....</b>	<b>350</b>
<b>Compare Index Register Y with Memory CPY.....</b>	<b>351</b>
<b>Decrement.....</b>	<b>352</b>
<b>Decrement Index Register X.....</b>	<b>353</b>
<b>Decrement Index Register Y.....</b>	<b>354</b>
<b>Exclusive-OR Accumulator with Memory.....</b>	<b>355</b>
<b>Increment.....</b>	<b>357</b>
<b>Increment Index Register X.....</b>	<b>358</b>
<b>Increment Index Register Y.....</b>	<b>359</b>
<b>Jump.....</b>	<b>360</b>
<b>Jump to Subroutine Long (Inter-Bank).....</b>	<b>361</b>
<b>Jump to Subroutine.....</b>	<b>362</b>
<b>Load Accumulator from Memory.....</b>	<b>363</b>
<b>Load Index Register X from Memory.....</b>	<b>364</b>
<b>Load Index Register Y from Memory.....</b>	<b>365</b>
<b>Logical Shift Memory or Accumulator Right.....</b>	<b>366</b>
<b>Block Move Next.....</b>	<b>367</b>
<b>Block Move Previous.....</b>	<b>368</b>
<b>MVP.....</b>	<b>368</b>
<b>No Operation.....</b>	<b>369</b>
<b>OR Accumulator with Memory.....</b>	<b>370</b>
<b>Push Effective Absolute Address.....</b>	<b>372</b>
<b>Push Effective Indirect Address.....</b>	<b>373</b>
<b>Push Effective PC Relative Indirect Address.....</b>	<b>374</b>
<b>PER.....</b>	<b>374</b>
<b>Push Accumulator.....</b>	<b>375</b>
<b>Push Data Bank Register.....</b>	<b>376</b>
<b>Push Direct Page Register.....</b>	<b>377</b>
<b>Push Program Bank Register.....</b>	<b>378</b>
<b>Push Processor Status Register.....</b>	<b>379</b>
<b>Push Index Register.....</b>	<b>380</b>
<b>Push Index Register.....</b>	<b>381</b>
<b>Pull Accumulator.....</b>	<b>382</b>
<b>Pull Data Bank Register.....</b>	<b>383</b>
<b>Pull Direct Page Register.....</b>	<b>384</b>
<b>Pull Status Flags.....</b>	<b>385</b>
<b>Pull Index Register X from Stack.....</b>	<b>386</b>
<b>Pull Index Register Y from Stack.....</b>	<b>387</b>
<b>Reset Status Bits.....</b>	<b>388</b>
<b>Rotate Memory or Accumulator Left.....</b>	<b>389</b>

## The Western Design Center

Rotate Memory or Accumulator Right.....	390
Return from Interrupt.....	391
Return from Subroutine Long.....	393
Return from Subroutine.....	394
Subtract with Borrow from Accumulator.....	395
Set Carry Flag.....	397
Set Decimal Mode Flag.....	398
Set Interrupt Disable Flag.....	399
Set Status Bits.....	400
Store Accumulator to Memory.....	401
Stop the Processor.....	402
Store Index Register X to Memory.....	403
Store Index Register Y to Memory.....	404
Store Zero to Memory.....	405
Transfer Accumulator to Index Register X.....	406
Transfer Accumulator to Index Register Y.....	407
Transfer 16-Bit Accumulator to Direct Page Register.....	408
Transfer Accumulator to Stack Pointer.....	409
Transfer Direct Page Register to 16-Bit Accumulator.....	410
Test and Reset Memory Bits Against Accumulator.....	411
Test and Set Memory Bits Against Accumulator.....	412
Transfer Stack Pointer to 16-Bit Accumulator.....	413
Transfer Stack Pointer to Index Register X.....	414
Transfer Index Register X to Accumulator.....	415
Transfer Index Register X to Stack Pointer.....	416
Transfer Index Register X to Y.....	417
Transfer Index Register Y to Accumulator.....	418
Transfer Index register Y to X.....	419
Wait for Interrupt.....	420
Reserved for Future Expansion.....	421
Exchange the B and A Accumulators.....	422
Exchange Carry and Emulation Bits.....	423
<b>19) Chapter Nineteen.....</b>	<b>424</b>
<b>Instruction Lists.....</b>	<b>424</b>
<b>Processor.....</b>	<b>434</b>
Addressing mode box:.....	434
Operation column:.....	434
Bytes, cycles, and status codes:.....	435
<b>Op Code Matrix Legend.....</b>	<b>437</b>

## Table of Figures

FIGURE 1-1 BINARY REPRESENTATION.....	13
FIGURE 1-2 BIT NUMBERS.....	14
FIGURE 1-3 ANDING BITS.....	16
FIGURE 1-4 ORING BITS.....	17
FIGURE 1-5 EXCLUSIVE ORING BITS.....	17
FIGURE 1-6 COMPLEMENTING BITS.....	18
FIGURE 1-7 COMPLEMENTING BITS USING EXCLUSIVE OR.....	18
FIGURE 1-8 MULTIPLE-PRECISION ARITHMETIC.....	21
FIGURE 1-9 TYPICAL ASSEMBLER SOURCE CODE.....	23
FIGURE 2-1 6502 PROGRAMMING MODEL.....	28
FIGURE 2-2 INITIALIZING THE STACK POINTER TO \$FF.....	32
FIGURE 2-3 AFTER PUSHING THE ACCUMULATOR.....	33
FIGURE 2-4 INDEXING: BASE PLUS INDEX.....	35
FIGURE 2-5 INDIRECTION: OPERAND LOCATES INDIRECT ADDRESS.....	36
FIGURE 4-1 65816 NATIVE MODE PROGRAMMING MODEL.....	46
FIGURE 4-2 RESULTS OF SWITCHING REGISTER SIZE.....	51



## The Western Design Center

FIGURE 4-3 65802 NATIVE MODE PROGRAMMING MODEL .....	57
FIGURE 4-4 65816 EMULATION MODE PROGRAMMING MODEL.....	60
FIGURE 6-1 STACK MEMORY .....	75
FIGURE 6-2. PUSH .....	77
FIGURE 6-3 REGISTER TRANSFERS BETWEEN DIFFERENT-SIZED REGISTERS .....	83
FIGURE 7-1 IMMEDIATE ADDRESSING: 8 VS. 16 BITS .....	91
FIGURE 7-2 ABSOLUTE ADDRESSING.....	93
FIGURE 7-3 ZERO PAGE ADDRESSING.....	94
FIGURE 7-4 INDEXING .....	97
FIGURE 7-5 INDEXING BEYOND THE END OF THE BANK .....	98
FIGURE 7-6 ABSOLUTE INDEXING WITH A GENERIC INDEX REGISTER .....	100
FIGURE 7-7 DIRECT PAGE INDEXING WITH A GENERIC INDEX REGISTER.....	102
FIGURE 7-8 DIRECT PAGE INDIRECT ADDRESSING .....	105
FIGURE 7-9 ABSOLUTE LONG ADDRESSING .....	108
FIGURE 7-10 DIRECT PAGE INDIRECT LONG ADDRESSING.....	110
FIGURE 8-1 JUMP'S ABSOLUTE INDIRECT ADDRESSING MODE .....	113
FIGURE 8-2. RELATIVE BRANCH CALCULATION .....	115
FIGURE 8-3. LINKED LIST .....	117
FIGURE 10-1 THE AND OPERATION.....	140
FIGURE 10-2 SHIFT AND ROTATE LEFT.....	148
FIGURE 10-3 SHIFT AND ROTATE RIGHT.....	149
FIGURE 11-1 POSTINDEXING.....	159
FIGURE 11-2 PREINDEXING.....	162
FIGURE 11-3 ABSOLUTE INDEXED INDIRECT.....	165
FIGURE 11-4 POSTINDEXED LONG.....	167
FIGURE 11-5 STACK RELATIVE .....	168
FIGURE 11-6 STACK RELATIVE INDIRECT INDEXED.....	169
FIGURE 11-7 PEA ADDRESSING.....	170
FIGURE 11-8 PEI ADDRESSING .....	171
FIGURE 11-9. PER ADDRESSING .....	172
FIGURE 12-1 JSR .....	176
FIGURE 12-2 RTS.....	177
FIGURE 12-3 JSL.....	178
FIGURE 12-4 RTL .....	179
FIGURE 13-1 I/O MANAGEMENT: INTERRUPTS VS. POLLING.....	193
FIGURE 13-2 INTERRUPT PROCESSING .....	194
FIGURE 13-3BREAK SIGNATURE BYTE ILLUSTRATION .....	197
FIGURE 13-4 6522 VIA INTERRUPT FLAG REGISTER.....	198
FIGURE 14-1 STACK SNAPSHOT AFTER PEI (12) INSTRUCTION.....	218
FIGURE 15-1 DISASSEMBLY OUTPUT.....	231
FIGURE 15-2 TRACER OUTPUT.....	231
FIGURE 17-1 6502/65C02 PROGRAMMING MODEL .....	284
FIGURE 17-2. 65802 NATIVE MODE PROGRAMMING MODEL.....	285
FIGURE 17-3 65816 NATIVE MODE PROGRAMMING MODEL.....	286
FIGURE 17-4 65816 EMULATION MODE PROGRAMMING MODEL.....	287
FIGURE 18-1 AND TRUTH TABLE.....	328
FIGURE 18-2 ASL .....	329
FIGURE 18-3 65802/65816 STACK AFTER BRK.....	339
FIGURE 18-4 STACK AFTER COP.....	349
FIGURE 18-5EXCLUSIVE OR TRUTH TABLE.....	355
FIGURE 18-6 LSR.....	366
FIGURE 18-7 LOGICAL OR TRUTH TABLE .....	370
FIGURE 18-8 ROL.....	389
FIGURE 18-9 ROR.....	390
FIGURE 18-10NATIVE MODE STACK BEFORE RTI.....	391
FIGURE 18-11 STACK BEFORE RTL.....	393
FIGURE 18-12 STACK BEFORE RTS .....	394

Table of Tables

TABLE 1-1 DECIMAL AND HEX NUMBERS ..... 15  
TABLE 1-2 TRUTH TABLE FOR AND ..... 17  
TABLE 1-3 TRUTH TABLE FOR OR ..... 17  
TABLE 1-4 TRUTH TABLE FOR EXCLUSIVE OR ..... 17  
TABLE 1-5 TRUTH TABLE FOR COMPLEMENT ..... 18  
TABLE 1-6 THE EIGHT-BIT RANGE OF TWO’S-COMPLEMENT NUMBERS ..... 19  
TABLE 1-7 THE FIRST 16 BCD NUMBERS ..... 20  
TABLE 2-1 STATUS REGISTER CONDITION CODE FLAGS..... 30  
TABLE 2-2 STATUS REGISTER MODE SELECT FLAGS..... 31  
TABLE 2-3 6502 ADDRESSING MODES ..... 34  
TABLE 2-4 6502 INSTRUCTIONS ..... 37  
TABLE 3-1 THE 65C02’S NEW ADDRESSING MODES..... 41  
TABLE 3-2. NEW 65C02 INSTRUCTIONS ..... 42  
TABLE 4-1 THE FOUR POSSIBLE NATIVE MODE REGISTER COMBINATIONS..... 49  
TABLE 4-2 ADDRESSING MODES: ZERO PAGE VS. DIRECT PAGE ..... 52  
TABLE 4-3 THE 65816/65802’S NEW ADDRESSING MODES..... 53  
TABLE 4-4 NEW 65816/65802 INSTRUCTIONS ..... 54  
TABLE 4-5 INTERRUPT VECTOR LOCATIONS..... 55  
TABLE 6-1 DATA MOVEMENT INSTRUCTION ..... 70  
TABLE 7-1 LIST OF SIMPLE ADDRESSING MODES..... 89  
TABLE 8-1. BRANCH AND JUMP INSTRUCTIONS..... 111  
TABLE 9-1 ARITHMETIC INSTRUCTIONS ..... 122  
TABLE 9-2. EQUALITIES..... 131  
TABLE 10-1 LOGIC INSTRUCTIONS ..... 139  
TABLE 11-1 COMPLEX ADDRESSING MODES ..... 154  
TABLE 11-2 COMPLEX PUSH INSTRUCTIONS..... 154  
TABLE 11-3 ASSEMBLER SYNTAX FOR COMPLETE MEMORY ACCESS ..... 157  
TABLE 12-1 SUBROUTINE INSTRUCTIONS ..... 174  
TABLE 13-1. INTERRUPT AND SYSTEM CONTROL INSTRUCTIONS..... 192  
TABLE 13-2 INTERRUPT VECTORS..... 195  
TABLE 13-3 RESET INITIALIZATION..... 201  
TABLE 17-1 OPERAND SYMBOLS ..... 284  
TABLE 18-1 OPERAND SYMBOLS ..... 326  
TABLE 18-2 65X FLAGS ..... 326

Part 1  
Basics

# 1) Chapter One

## Basic Assembly Language Programming Concepts

This chapter reviews some of the key concepts that must be mastered prior to learning to program a computer in assembly language. These concepts include the use of the **binary** and **hexadecimal** number systems; **boolean logic**; how memory is **addressed** as **bytes** of data; how characters are represented as **ASCII** codes; **binary-coded decimal (BCD) number** systems, and more. The meaning of these terms is explained in this chapter. Also discussed is the use of an **assembler**, which is a program used to write machine-language programs, and programming techniques like **selection**, **loops**, and **subroutines**.

Since the primary purpose of this book is to introduce you to programming the 65816 and the other members of the 65x family, this single chapter can only be a survey of this information rather than a complete guide.

### Binary Numbers

In its normal, everyday work, most of the world uses the *decimal*, or *base ten*, number system, and everyone takes for granted that this system is the “natural” (or even the only) way to express the concept of numbers. Each place in a decimal number stands for a power of ten: ten to the 0 power is 1, ten to the 1<sup>st</sup> power is ten, ten to the 2<sup>nd</sup> power is 100, and so on. Thus, starting from a whole number’s right-most digit and working your way left, the first digit is multiplied by the zero power of ten, the second by the first power of ten, and so on. The right-most digits are called the **low-order** or **least significant** digits in a **positional notation** system such as this, because they contribute least to the total magnitude of the number; conversely, the leftmost digits are called the **high-order** or **most significant** digits, because they add the most weight to the value of the number. Such a system is called a **positional notation** system because the position of a digit within a string of numbers determines its value.

Presumably, it was convenient and natural for early humans to count in multiples of ten because they had ten fingers to count with. But it is rather inconvenient for digital computers to count in decimal; they have the equivalent of only one finger, since the representation of numbers in a computer is simply the reflection of electrical charges, which are either on or off in a given circuit. The all or nothing nature of digital circuitry lends itself to the use of the **binary**, or **base two**, system of numbers, with one represented by “on” and zero represented by “off”. A one or a zero in binary arithmetic is called a **binary digit**, or a **bit** for short.

Like base ten digits, base two digits can be strung together to represent numbers larger than a single digit can represent, using the same technique of positional notation described for base ten numbers above. In this case, each binary digit is such a base two number represents a power of two, with a whole number’s right-most bit representing two to the zero power (ones), the next bit representing two to the first power (twos), the next representing two to the second power (fours), and so on (Figure 1-1 Binary Representation)

## Grouping Bits into Bytes

As explained, if the value of a binary digit, or bit, is a one, it is stored in a computer’s memory by switching to an “on” or charged state, in which case the bit is described as being **set**; if the value of a given bit is a zero, it is marked in memory by switching to an “off” state, and the bit is said to be **reset**.

While memory may be filled with thousands or even millions of bits, a microprocessor must be able to deal with them in a workable size.

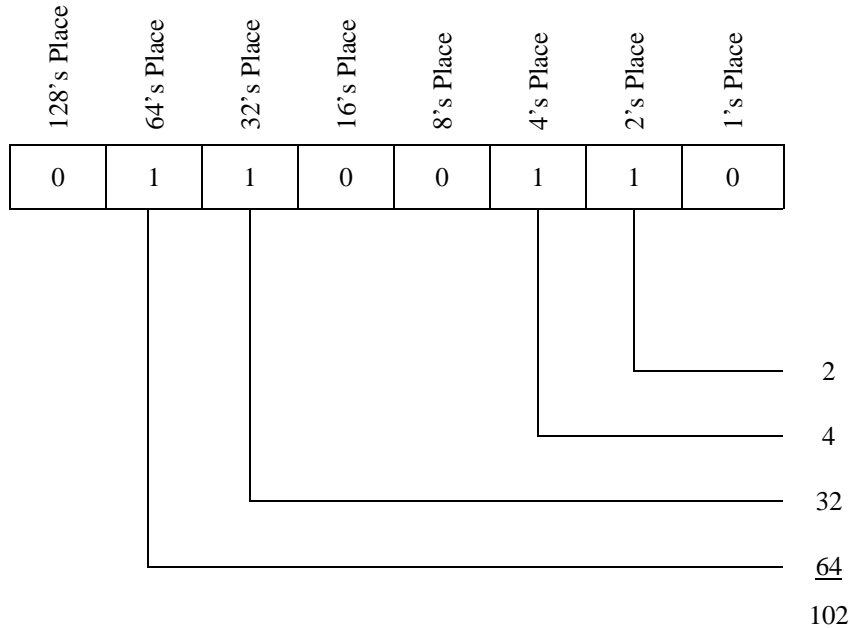

**Figure 1-1 Binary Representation**

The smallest memory location that can be individually referenced, or **addressed**, is usually, and always in the case of the 65x processors, a group of eight bits. This basic eight-bit unit of memory is known as a **byte**. Different types of processors can operate on different numbers of bits at any given time, with most microprocessors handling one, two, or four bytes of memory in a single operation. The 6502 and 65C02 processors can handle only eight bits at a time. The 65816 and 65802 can process either eight or sixteen bits at a time.

Memory is organized as adjacent, non-overlapping bytes, each of which has its own specific **address**. An address is the unique, sequential identifying number used to reference the byte at a particular location. Addresses start at zero and continue in ascending numeric order up to the highest addressable location.

As stated, the 65802 and 65816 can optionally manipulate two adjacent bytes at the same time; a sixteen-bit data item stored in two contiguous bytes is called a **double byte** in this book. A more common but misleading usage is to describe a sixteen-bit value as a **word**; the term word is more properly used to describe the number of bits a processor fetches in a single operation, which may be eight, sixteen, thirty-two, or some other number of bits depending on the type of processor.

It turns out that bytes – multiples of eight bits – are conveniently sized storage units for programming microprocessors. For example, a single byte can readily store enough information to uniquely represent all of the characters in the normal computer character set. An eight-bit binary value can be easily converted to two hexadecimal (base sixteen) digits; this fact provides a useful intermediate notation between the binary and decimal number systems. A double byte can represent the entire range of memory addressable by the 6502, 65C02, and 65802, and one complete **bank** – 64K bytes – on the 65816. Once you’ve adjusted to it, you’ll find that there is a consistent logic behind the organization of a computer’s memory into eight-bit bytes.

Since the byte is one of the standard units of a computer system, a good question to ask at this point would be just how large a decimal number can you store in eight bits? The answer is 255. The largest binary number you can store in a given number of bits is the number represented by that many one-bits. In the case of

## The Western Design Center

the byte, this is 11111111, or 255 decimal (or  $2^8 - 1$ ). Larger numbers are formed by storing longer bit-strings in consecutive bytes.

The size of a computer's memory is typically expressed in bytes, which makes sense because the byte is the smallest addressable unit. And since a byte is required to store the representation of a single alphanumeric character, you can get an easy visualization of about how much storage 64K of memory is by thinking of that many characters. The **K** stands for one thousand (from the Greek *kilo* meaning thousand, as in kilogram or kilometer); however, since powers of two are always much more relevant when discussing computer memories, the symbol K in this context actually stands for 1024 bytes, the nearest power-of-two approximation of 1000, so 64K is 65,536 bytes, 128K is 131,072 bytes, and so on. Within a given byte (or double byte) it is often necessary to refer to specific bits within the word. Bits are referred to by number. The low-order, or right-most bit, is called bit zero; this corresponds to the one's place. The next-higher-order bit is bit one, and so on. The high-order bit of a byte is therefore bit seven; of a double byte, bit fifteen. The convention of calling the lower-order bit the "right-most" is consistent with the convention used in decimal positional notation; normal decimal numbers are read from left to right, from high-order to low-order. Figure 1.2 illustrates the bit numbers for bytes and double bytes, as well as the relative weights of each bit position.

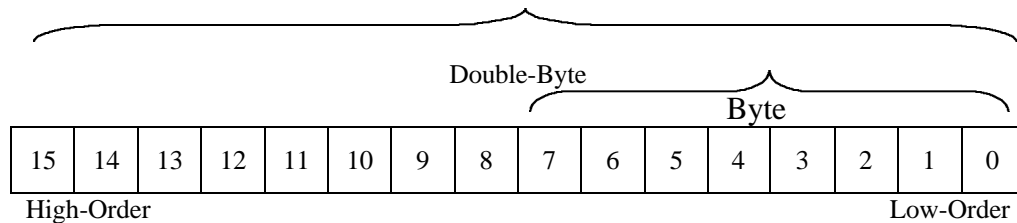

Figure 1-2 Bit Numbers

## Hexadecimal Representation of Binary

While binary is a convenient number system for computers to use, it is somewhat difficult to translate a series of ones and zeros into a number that is meaningful. Any number that can be represented by eight binary bits can also be represented by two **hexadecimal** (or **hex** for short) digits. Hexadecimal numbers are base sixteen numbers. Since base two uses the digits zero through one, and base ten the digits zero through nine, clearly base sixteen must use digits standing for the numbers zero through fifteen. Table 1.1 is a chart of the sixteen possible four-bit numbers, with their respective decimal and hexadecimal representations.

<i>Binary</i>	<i>Decimal</i>	<i>Hexadecimal</i>
0000	0	0
0001	1	1
0010	2	2
0011	3	3
0100	4	4
0101	5	5
0110	6	6
0111	7	7
1000	8	8
1001	9	9
1010	10	A
1011	11	B
1100	12	C
1101	13	D
1110	14	E
1111	15	F

**Table 1-1 Decimal and Hex Numbers**

Because the positional notation convention reserves only a single place for each multiplier of the power of that base, the numbers ten through fifteen must be represented by a single base-sixteen digit. Rather than create entirely new symbols for digits, the first six letters of the alphabet were chosen to represent the numbers ten through fifteen. Each of the sixteen hex digits corresponds to one of the possible combinations of four binary digits.

Binary numbers larger than 1111 are converted to hexadecimal by first separating the bits into groups of four, starting from the right-most digit and moving left. Each group of four bits is converted into its corresponding hex equivalent. It is generally easier to work with a hexadecimal number like F93B than its binary counterpart 111100100111011. Hexadecimal numbers are often used by machine language programming tools such as assemblers, monitors, and debuggers to represent memory addresses and their contents. The value of hexadecimal numbers is the ease with which they can be converted to and from their binary equivalents once the table has been memorized.

While a hexadecimal 3 and a decimal 3 stand for the same number, a hexadecimal 23 represents two decimal sixteen's plus 3, or 35 decimal. To distinguish a multiple-digit hex number from a decimal one, either the word hexadecimal should precede or follow it, or a '\$' should prefix it, as in \$23 for decimal 35, or \$FF to represent 255. A number without any indication of base is presumed to be decimal. An alternative notation for hexadecimal numbers is to use the letter **H** as a suffix to the number (for example, FFH); however, the dollar-sign prefix is generally used by assemblers for the 65x processors.

## The ASCII

Characters – letters, numbers, and punctuation – are stored in the computer as number values, and translated to and from readable form on input or output by hardware such as keyboards, printers, and CRTs. There are 26 English-language lower-case letters, another 26 upper-case ones, and a score or so of special characters, plus the ten numeric digits, any of which might be typed from a keyboard or displayed on a screen or printer, as well as stored or manipulated internally. Further, additional codes may be needed to tell a terminal or printer to perform a given function, such as cursor or print head positioning. These **control codes** including **carriage return**, which returns the cursor or print head to the beginning of a line; **line feed**, which moves the cursor or print head down a line; **bell**, which rings a bell; and **back space**, which moves the cursor or print head back one character.

The **American Standard Code for Information Interchange** abbreviated **ASCII** and pronounced AS key, was designed to provide a common representation of characters for all computers. An ASCII code is stored in the low-order seven bits of a byte; the most significant bit is conventionally a zero, although a system can be designed either to expect it to be set or to ignore it. Seven bits allow the ASCII set to provide 128 different character codes, one for each English letter and number, most punctuation marks, the most commonly use mathematical symbols, and 32 control codes.

## The Western Design Center

The use of different bit values, or numbers, to store character codes, is entirely analogous to the “decoder ring” type of cipher: the letter ‘A’ is one, ‘B’ is two, and so on; but in the case of the ASCII character set, the numbers assigned to the letters of the alphabet are different, and there are different codes for upper- and lower-case letters.

There is an ASCII chart in Appendix F of this book. Notice that since the decimal digits 0 through 9 are represented by \$30 to \$39, they can be easily converted between their binary representations and their actual values by the addition or subtraction of \$30. The letters are arranged in alphabetical order, the capital letters from A through Z represented by \$41 through \$5A and the lower-case letters from a through z represented by \$61 through \$7A. This allows letters to be placed in alphabetical order by numerically sorting their ASCII values, and characters to be converted between upper- and lower-case by the addition or subtraction of \$20. Finally, notice that the control characters from Ctrl-@ and Ctrl-A through Ctrl-Z and on to Ctrl-\_ run from zero to \$1F and allow easy conversion between the control characters and the equivalent printing characters by the addition or subtraction of \$40.

To print a character on an output device, you must send it the ASCII value of the character: to print an ‘A’, you must send \$41 to the screen, not \$A, which is the ASCII code for a line feed; and to print an ‘8’, you must send \$38, not \$8, which is the ASCII code for a backspace. The space character, too, has an ASCII code: \$20.

Since any memory value – take \$41 for example – could represent either an ASCII code (for ‘A’ in this case) or a number (decimal 65), the interpretation of the data is defined by the code of the program itself and how it treats each piece of data it uses within a given context.

## Boolean Logic

Logical operations interpret the binary on/off states of a computer’s memory as the values **true** and **false** rather than the numbers one and zero. Since the computer handles data one or two bytes at a time, each logical operation actually manipulates a set of bits, each with its own position.

Logical operations manipulate binary “flags”. There are three logical operations that are supported by 65x microprocessor instructions, each combining two operands to yield a logical (true or false) result: and, or, and exclusive or.

### *Logical And*

The **AND** operator yields **true** only if *both* of the operands are themselves true; otherwise, it yields false. Remember, true is equivalent to one, and false equivalent to zero. Within the 65x processors, two strings of eight, or in the case of the 65816, eight or sixteen, individual logical values may be ANDed, generating a third string of bits; each bit in the third set is the result of ANDing the respective bit in each of the first two operands. As a result, the operation is called **bitwise**.

When considering bitwise logical operations, it is normal to use binary representation. When considered as a *numeric* operation on two binary numbers, the result given in Figure 1.3 makes little sense. By examining each bit of the result, however, you will see that each has been determined by ANDing the two corresponding operand bits.

	11011010	\$DA
AND	01000110	\$45
equals	01000010	\$42

**Figure 1-3 ANDing Bits**



## The Western Design Center

A **truth table** can be drawn for two-operand logical operations. You find the result of ANDing two bits by finding the setting of one bit on the left and following across until you're under the setting of the other bit. Table 1.2 shows the truth table for AND.

0	1	<i>Second Operand</i>
		<i>First Operand</i>
		0    0
		1    0    1

**Table 1-2 Truth Table for AND**

### Logical Or

The **OR** operator yields a one or true value if either (or both) of the operands is true. Taking the same values as before, examine the result of the logical OR operation in Figure 1.4. The truth table for the OR function is shown in Table 1.3.

	11011010	\$DA
OR	01000110	\$45
equals	11011110	\$DE

**Figure 1-4 ORing Bits**

### Logical Exclusive Or

The **exclusive OR** operator is similar to the previously-described OR operation; in this case, the result is true only if one or the other of the operands is true, but not if both are true or (as with OR) neither is true. That is, the result is true only if the operands are *different*, as Figure 1.5 illustrates using the same values as before. The truth table for exclusive OR is shown in Table 1.4.

0	1	<i>Second Operand</i>
		<i>First Operand</i>
		0    0    1
		1    1    1

**Table 1-3 Truth Table for OR**

	11011010	\$DA
EOR	01000110	\$45
equals	10011100	\$9C

**Figure 1-5 EXCLUSIVE ORing Bits**

0	1	<i>Second Operand</i>
		<i>First Operand</i>
		0    0    1
		1    1    0

**Table 1-4 Truth Table for EXCLUSIVE OR**

### Logical Complement

As Figure 1.6 shows, the logical **complement** of a value is its inverse: the complement of true is false, and the complement of false is true.

$$\begin{array}{rcl}
 & & 11011010 & \$DA \\
 \text{COMPLEMENTED} & \text{-----} & & \\
 \text{equals} & & 00100101 & \$25
 \end{array}$$

**Figure 1-6 COMPLEMENTING Bits**

While the 65x processors have no complement or **not** function built in, **exclusive ORing** a value with a string of ones (\$FF or \$FFFF) produces the complement, as Figure 1.7 illustrates.

$$\begin{array}{rcl}
 & & 11011010 & \$DA \\
 \text{EOR} & & 11111111 & \$FF \\
 \text{equals Complement} & \text{-----} & 00100101 & \$25
 \end{array}$$

**Figure 1-7 COMPLEMENTING Bits Using Exclusive OR**

Since complement has only one operand, its truth table, drawn in Table 1.5, is simpler than the other truth tables.

operand	result
0	1
1	0

**Table 1-5 Truth Table for COMPLEMENT**

## Signed Numbers

Many programs need nothing more than the whole numbers already discussed. But others need to store and perform arithmetic on both positive and negative numbers.

Of the possible systems for representing signed numbers, most microprocessors, among them those in the 65x family, use **two's complement**. Using two's-complement form, positive numbers are distinguished from negative ones by the most significant bit of the number: a zero means the number is positive; a one means it is negative.

To negate a number in the two's-complement system, you first complement each of its bits, then add one. For example, to negate one (to turn plus-one into minus-one):

$$\begin{array}{rcl}
 00000001 & \text{To negate +1,} \\
 11111110 & \text{complement each bit} \\
 \quad \quad +1 & \text{and add one.} \\
 \hline
 11111111 & \text{The result is - 1.}
 \end{array}$$

So \$FF is the two's-complement representation of minus-one. When converting to two's complement by hand, an easier technique than the two-step process is to copy zeroes from the right (least significant bit) until the first one is reached; copy that one, and then change every zero to a one and every one to a zero as you continue to the left. Try it on the example above.

Now, instead of using eight bits to represent the integers from zero to 255, two's-complement arithmetic uses eight bits to represent signed numbers from -128 (\$80) to +127 (\$7F), as Table 1.6 shows. There is always one more negative than positive number in a two's-complement system.

Decimal	Hexadecimal	Binary
+127	\$7F	0111 1111
+126	\$7E	0111 1110
+125	\$7D	0111 1101
.	.	.
.	.	.
.	.	.
+1	1	0000 0001
0	0	0000 0000
-1	\$FF	1111 1111
-2	\$FE	1111 1110
-3	\$FD	1111 1101
.	.	.
.	.	.
.	.	.
-126	\$82	1000 0010
-127	\$81	1000 0001
-128	\$80	1000 0000

**Table 1-6 The Eight-Bit Range of Two's-Complement Numbers**

Another practical way to think of negative two's-complement numbers is to think of negative numbers as the (unsigned) value that must be added to the corresponding positive number to produce zero as the result. For example, in an eight-bit number system, the value that must be added to one to produce zero (disregarding the carry) is \$FF;  $1 + \$FF = \$100$ , or 0 if only the low-order eight bits is considered. \$FF must therefore be the two's-complement value for minus one.

The introduction of two's-complement notation creates yet another possibility in interpreting the data stored at an arbitrary memory location. Since \$FF could represent either the unsigned number 255 or the negative integer minus-one, it's important to remember that it is only the way in which a program interprets the data stored in memory that gives it its proper value – signed or unsigned.

### Storing Numbers in Decimal Form

Computers use numbers in binary form most efficiently. But when a program calls for decimal numbers to be entered or output frequently, storing numbers in their decimal form – rather than converting them to binary and back – may be preferable. Further, converting floating-point decimal numbers to a binary floating-point form and back can introduce errors: for example, 8 minus 2.1 could result in 5.90000001 rather than the correct answer, 5.9.

As a result, some programs, such as accounting applications, store numbers in decimal form, each decimal digit represented by four bits, yielding two decimals digits per byte, as Table 1.7 shows. This form is called **binary-coded decimal** BCD lies somewhere between the machine's native binary and abstractions such as the ASCII character codes for numbers.

Since four bits can represent the decimal numbers from zero to fifteen, using the same number of bits to represent only the numbers from zero through nine wastes six combinations of the binary digits. This less than optimal use of storage is the price of decimal accuracy and convenience.

Binary	Hexadecimal	Decimal	BCD
0000 0000	0	0	0000 0000
0000 0001	1	1	0000 0001
0000 0010	2	2	0000 0010
0000 0011	3	3	0000 0011
0000 0100	4	4	0000 0100
0000 0101	5	5	0000 0101
0000 0110	6	6	0000 0110
0000 0111	7	7	0000 0111
0000 1000	8	8	0000 1000
0000 1001	9	9	0000 1001
0000 1010	A	10	0001 0000
0000 1011	B	11	0001 0001
0000 1100	C	12	0001 0010
0000 1101	D	13	0001 0011
0000 1110	E	14	0001 0100
0000 1111	F	15	0001 0101

**Table 1-7 The First 16 BCD Numbers**

The 65x processors have a special decimal mode which can be set by the programmer. When decimal mode is set, numbers are added and subtracted with the assumption that they are BCD numbers: in BCD mode, for example, 1001+1 (9+1) yields the BCD results of 0001 0000 rather than the binary result of 1010 (1010 has no meaning in the context of BCD number representation).

Obviously, in different context 0001 0000 could represent either 10 decimal or \$10 hexadecimal (16 decimal); in this case, the interpretation is dependent on whether the processor is in decimal mode or not.

### Computer Arithmetic

Binary arithmetic is just like decimal arithmetic, except that the highest digit isn't nine, it's one. Thus 1+0=1, while 1+1=0 with a carry of 1, or binary 10. Binary of 10 is equivalent of a decimal 2. And 1-0=1, while during the subtraction of binary 1 from binary 10, the 1 can't be subtracted from the 0, so a borrow is done, getting the 1 from the next position (leaving it 0); thus, 10-1=1.

Addition and subtraction are generally performed in one or more main processor registers, called accumulators. On the 65x processors, they can store either one or, optionally on the 65802 and 65816, two bytes. When two numbers are added that cause a carry from the highest bit in the accumulator, the result is larger than the accumulator can hold. To account for this, there is a special one-bit location, called a **carry bit**, which holds the carry out of the high bit from an addition. Very large numbers can be added by adding the low-order eight or sixteen bits (whichever the accumulator holds) of the numbers, and then adding the next set of bit plus the carry from the previous addition, and so on. Figure 1.8 illustrates this concept of multiple-precision arithmetic.

### Microprocessor Programming

You have seen how various kinds of data are represented and, in general, how this data can be manipulated. To make those operations take place, a programmer must instruct the computer on the steps it must take to get the data, the operations to perform on it, and finally the steps to deliver the results in the appropriate manner. Just as a record player is useless without a record to play, so a computer is useless without a program to execute.

### Machine Language

The microprocessor itself speaks only one language, its **machine language**, which inevitably is just another form of binary data. Each chip design has its own set of machine language instructions, called its **instruction set**, which defines the function that it can understand and execute. Whether you program in machine language, in its corresponding assembly language, or in a higher level language like BASIC or Pascal, the instructions that the microprocessor ultimately executes are always machine language instructions. Programs in assembly and higher-level languages are translated (by assemblers, compilers and interpreters) to machine language before the processor can execute them.

## The Western Design Center

Each machine language instruction in the 65x series of microprocessors is one to four bytes long. The first byte of each instruction is called the **operation code (opcode)** for short; it specifies the operation the computer is to do. Any additional bytes in the instruction make up the **operand**, typically all or part of an address to be accessed, or a value to be processed.

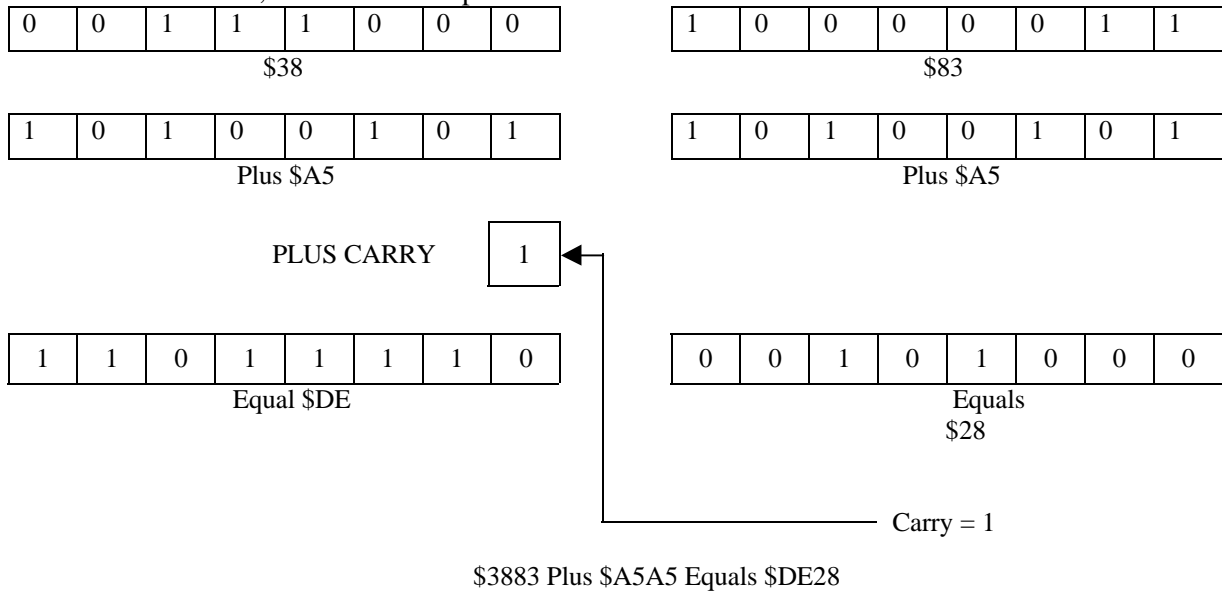

**Figure 1-8 Multiple-Precision Arithmetic**

## The Western Design Center

### *Assembly Language*

Writing long strings of hexadecimal or binary instructions to program a computer is obviously not something you would want to do if you could at all avoid it. The 65816's 256 different opcodes, for example, would be difficult to remember in hexadecimal form – and even harder in binary form. **Assembly language**, and programs which translate assembly language to machine code (called **assemblers**) were devised to simplify the task of machine programming.

Assembly language substitutes a short word – known as a **mnemonic** (which means memory aid) – for each binary machine code instruction. So while the machine code instruction 1010 1010, which instructs the 65x processor to transfer the contents of the A accumulator to the X index register, may be hard to remember, its assembler mnemonic TAX (for “Transfer A to X”) is much easier.

The entire set of 65x opcodes are covered alphabetically by mnemonic label in Chapter Eighteen, while Chapter Five through Thirteen discuss them in functional groups, introducing each of them, and providing examples of their use.

To write an assembly language program, you first use a text editing program to create a file containing the series of instruction mnemonics and operands that comprise it; this is called the **source program**, **source code** or just **source**. You then use this as the input to the assembler program, which translates the assembler statements into machine code, storing the generated code in an output file. The machine code is either in the form of **executable object code**, which is ready to be executed by the computer, or (using some development systems), a **relocatable object module**, which can be linked together with other assembled object modules before execution.

If this were all that assembly language provided, it would be enough to make machine programming practical. But just as the assembler lets you substitute instruction mnemonics for binary operation codes, it lets you use names for the memory locations specified in operands so you don't have to remember or compute their addresses. By naming routines, instructions which transfer control to them can be coded without having to know their addresses. By naming constant data, the value of each constant is stated only in one place, the place where it is named. If a program modification requires you to change the values of the constants, changing the definition of the constant in that one place changes the value wherever the name has been used in the program. These symbolic names given to routines and data are known as **labels**.

As your source program changes during development, the assembler will resolve each label reference anew each time an assembly is performed, allowing code insertions and deletions to be made. If you hard-coded the addresses yourself, you would have to recalculate them by hand each time you inserted or deleted a line of code.

The use of an assembler also lets you **comment** your program within the source file – that is, to explain in English what it is you intend the adjacent assembly statements to do and accomplish.

More sophisticated **macro assemblers** take symbol manipulation even further, allowing special labels, called **macro instructions** (or just **macros** for short), to be assigned to a whole series of instructions. *Macro* is a Greek word meaning *long*, so a macro instruction is a “long” instruction. Macros usually represent a series of instructions which will appear in the code frequently with slight variations. When you need the series, you can type in just the macro name, as though it were an instruction mnemonic; the assembler automatically “expand” the macro instruction to the previously-defined string of instructions. Slight variations in the expansion are provided for by a mechanism that allows macro instructions to have operands.

### **Writing in Assembly Language**

In addition to understanding the processor you're working with, you must also have a good knowledge of the particular assembler you are using to program in assembly language. While the specific opcodes used are carved in the silicon die of the processor itself, the mnemonics for those opcodes are simple conventions and may vary slightly from one assembler to another (although the mnemonics proposed by a processor's manufacturer will tend to be seen as the standard). Varying even more widely are assembler **directives** – assembler options which can be specified in the midst of code. These options tell the assembler such things as where to locate the program in memory, which portions of the source listing to print, or what labels to assign to constants.

## The Western Design Center

Nevertheless, most microcomputer assemblers have a great deal in common. They generally provide four columns, or **fields**, for different types of information about an operation: a label which can be used to symbolically identify the location of the code; the opcode; the operand; and space for comments. Figure 1.9 illustrates some typical assembler source code, with the different fields highlighted.

While an opcode or directive appears in every assembler statement, the operand field may or may not be required by any particular opcode, since there are several one-byte instructions which consist solely of an opcode. The label and comment field are optional, added to make the program easier to read, write, debug, and modify later.

During assembly, the assembler checks the fields to be sure the information there is complete, of the proper type, and not out of order, and issues error messages to warn you problems. It also checks to be sure you have not tried to define the same label twice, and that you have not used a label you did not define.

## Basic Programming Concepts

There are several concepts which, in general terms, characterize the different ways a program can execute.

The most obvious concept is that of **straight-line execution**: a program starts in low memory and steps a few bytes higher into memory with execution of each new instruction until it reaches the end, never doubling back or jumping forward. Straight-line execution is clean and clear: it begins at the beginning, executes every instruction in the program once, and ends at the end. This type of execution is the default execution mode. The 65x processors have register called the **program counter**, which is automatically updated at the end of each instruction so that it contains the address of the next instruction to be executed.

<i>Label Field</i>	<i>Opcode Field</i>	<i>Operand Field</i>	<i>Comment Field</i>
	REP	#\$10	
	LONGI	ON	
	SEP	#\$20	
	LONGA	OFF	
LOOP	LDY	#0	
	LDA	(1,S),Y	get character from first string
	BEQ	PASS	if zero, end of string: match
	CMP	(3,S),Y	compare to corresponding char in 2 <sup>nd</sup> string
	BNE	FAIL	bra if not equal; probably failure
	INY		else do not pair
	BRA	LOOP	
;		matches shortest string	
PASS	PLP		they match up to shortest string;
	CLC		restore status, but clear carry
	BRA	EXIT	
FAIL	LDA	(3,S),Y	was last failure due to end of string2?
	BEQ	PASS	yes; let it pass
	PLP		restore status, but set carry (no match)
	SEC		

**Figure 1-9 Typical Assembler Source Code**

## The Western Design Center

### *Selection Between Paths*

Real-life problems – the kind you want to write computer programs to solve – are seldom straight and simple. A computer would be very limited with only straight-line execution capability, that is, if it could not make choices between different courses of action based on the conditions that exist while it is executing. Selection between paths provides computers with their decision-making capabilities. The 65x microprocessors carry out selection between paths by means of **conditional branch instructions**.

An example of selection between paths would be a tic-tac-toe program. Playing second, the program must choose where to place its first token from eight different squares. If the opponent has taken the center square, the program must respond differently than if a side square were taken.

Execution still begins at the beginning and ends at the end, in a single pass through the code, but whole groups of instructions on paths not taken are not executed.

### *Looping*

Let's say you write a program to convert a Fahrenheit temperature to Celsius. If you had only one temperature to convert, you wouldn't spend the time writing a program. What you want the program to do is prompt for a Fahrenheit temperature, convert it to Celsius, print out the result, then loop back and prompt for another Fahrenheit temperature, and so on – until you run out of temperatures to convert. This program uses a program concept called **looping** or **iteration**, which is simply the idea that the same code can be reexecuted repeatedly – with different values for key variables – until a given exit condition. In this case the exit condition might be the entry of a null or empty input string.

Often, it's not the whole program that loops, but just a portion of it. While a poker program could deal out 20 cards, one at a time, to four players, it would use much less program memory to deal out one card to each of the players, then loop back to do the same thing over again four more times, before going on to take bets and play the poker hands dealt.

Looping saves writing repetitive code over and over again, which is both tedious and uses up memory. The 65x microprocessors execute loops by means of **branch** and **jump** instructions.

Looping almost always uses the principle of selection between paths to handle exiting the loop. In the poker program, after each set of four cards has been dealt to the four players, the program must decide if that was the fifth set of four cards or if there are more to deal. Four times it will select to loop back and deal another set; the fifth time, it will select another path – to break out of the loop to begin prompting for bets.

### *Subroutines*

Even with loops, programmers could find themselves writing the same section of code over and over when it appears in a program not in quick succession but rather recurring at irregular intervals throughout the program. The solution is to make the section of code a **subroutine**, which the program can call as many times and from as many locations as it needs to by means of a **jump-to-subroutine** instruction. The program, on encountering the subroutine call, makes note of its current location for purposes of returning to it, then jumps to the beginning of the subroutine code. At the end of the subroutine code, a **return-from-subroutine** instruction tells the program to return from the subroutine to the instruction after the subroutine call. There are several different types of calls and returns available on the different 65x processors; all of them have a basic call and return instruction in common.

Programmers often build up large **libraries** of general subroutines that multiply, divide, output messages, send bytes to and receive bytes from a communications line, output binary numbers in ASCII, translate numbers from keyboard ASCII into binary, and so on. Then when one of these subroutines is needed, the programmer can get a copy from the library or include the entire library as part of his program.



Part 2  
Architecture

## 2) Chapter Two

### Architecture of the 6502

This chapter, and the two which follow, provide overviews of the architecture of the four 65x family processors: the 6502, the 65C02, and the 65802/65816. Each chapter discusses the register set and the function of the individual registers, the memory model, the addressing modes, and the kinds of operations available for each respective processor. Because each successive processor is a superset of the previous one, each of the next two chapters will build on the material already covered. Much of what is discussed in this chapter will not be repeated in the next two chapters because it is true of *all* 65x processors. As the original 65x machine, the 6502 architecture is particularly fundamental, since it describes a great number of common architectural features.

### Microprocessor Architecture

The number, kinds, and sizes of registers, and the types of operations available using them, defines the **architecture** of a processor. This architecture determines the way in which programming problems will be solved. An approach which is simple and straightforward on one processor may become clumsy and inefficient on another if the architectures are radically different.

A **register** is a special memory location within the processor itself, where intermediate results, addresses, and other information which must be accessed quickly are stored. Since the registers are within the processor itself, they can be accessed and manipulated much faster than external memory. Some instructions perform operations on only a single bit within a register; others on two registers at once; and others move data between a register within the processor and external memory. (Although the registers are indeed a special kind of memory, the term **memory** will be used only to refer to the addressable memory external to the microprocessor registers.)

The 6502 is not a **register-oriented** machine. As you will see, it has a comparatively small set of registers, each dedicated to a special purpose. The 6502 instead relies on its large number of addressing modes, particularly its direct-page indirect addressing modes, to give it power.

An **addressing mode** is a method, which may incorporate several intermediate calculations involving index registers, offset, and base addresses, for generating an instruction's **effective address** – the memory address at which data is read or written. Many 6502 instructions, such as those for addition, have many alternate forms, each specifying a different addressing mode. The selection of the addressing mode by you, the programmer, determines the way in which the effective address will be calculated.

There are three aspects to learning how to program the 6502 or any processor. Learning the different addressing modes available and how to use them is a big part. Learning the available instructions and operations, such as addition, subtraction, branching, and comparing, is another. But to make sense of either, you must begin by understanding what each of the different registers is and does, and how the memory is organized.

If you compare the different processors in the 65x family – the eight-bit 6502 and 65C02 and the sixteen-bit 65816 and 65802 – you will find they all have a basic set of registers and a basic set of addressing modes in common: the 6502's.

### The 6502 Registers

The 6502 registers are:

- The **accumulator**, or **A** register, is the primary user register and generally holds one of the operands, as well as the result, of any of the basic data-manipulation instructions.
- The **X** and **Y index** registers are used chiefly in forming effective addresses for memory accesses and as loop counters.
- The **processor status**, or **P**, register contains bit-fields to indicate various conditions, modes, and results within the processor.
- The **stack pointer**, or **S** register, is a pointer to the next available location on the system stack, a special area of memory for temporary data storage. In addition to being available to the user, the stack pointer and stack are also used automatically every time a subroutine is called or an interrupt occurs to store return information.

## The Western Design Center

- Finally, the **program counter**, or **PC**, is a pointer to the memory location of the instruction to be executed next.

These six basic 6502 registers are depicted in the **programmer model** diagrammed in Figure 2.1. Notice that, with the exception of the program counter (**PC**), all of them are eight-bit registers. Because they can contain only eight bits, or one byte, of data at a time, they can only perform operations, such as addition, on one byte at a time. Hence the 6502 is characterized as an “eight-bit” processor.

Although the user registers of the 6502 are only eight bits wide, all of the external addresses generated are sixteen bits. This gives the 6502 an **address space** of 64K ( $2^{16}=65,536$ ). In order to access data located anywhere in that 64K space with an eight bit processor, one instruction operand in calculating effective addresses is almost always found in memory – either in the code itself following an instruction, or at a specified memory location – rather than in a register, because operands in memory have no such limits. All that is needed to make a memory operand sixteen bits are two adjacent memory locations to put them in.

To allow programs longer than 256 bytes, the program counter, which always points to the location of the next instruction to be executed, is necessarily sixteen bits, or two bytes, wide. You may therefore locate a 6502 program anywhere within its 64K address space.

Now each of the 6502 registers will be described in more detail.

### *The Accumulator*

The accumulator (**A**) is the primary register in the 65x processor. Almost all arithmetic and most local operations are performed on the data in the accumulator, with the result of the operation being stored in the accumulator. For example to add two numbers which are stored in memory, you must first load one of them into the accumulator. Then you add the other to it and the result is automatically stored in the accumulator, replacing the value previously loaded there.

Because the accumulator is the primary user register, there are more addressing modes for accumulator operations than for any other register.

The 6502 accumulator is an eight-bit register. Only one byte is ever fetched from memory when the accumulator is loaded, or for operations which use two values – one from memory and the other in the accumulator (as in the addition example above).

6502 Programming Model

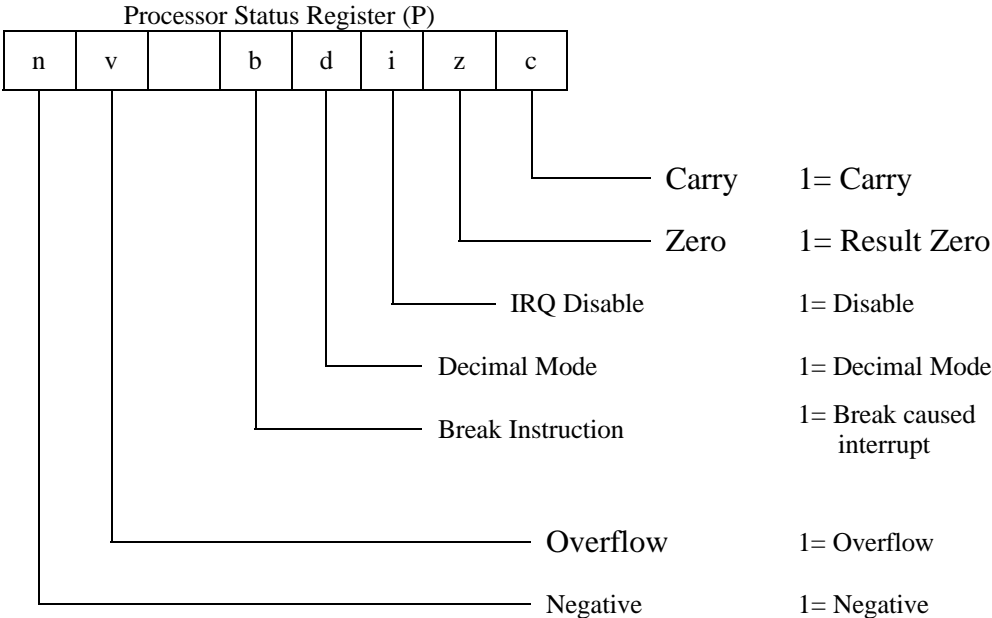
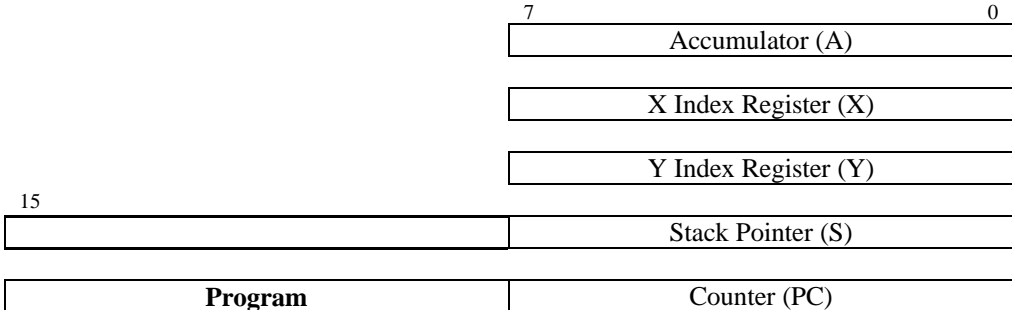

Figure 2-1 6502 Programming Model

## The Western Design Center

### *The X and Y Index Registers*

The index registers are generally used either as components in generating effective addresses when any of the indexed addressing modes are used, or as loop counters. They can be easily **incremented** or **decremented**; that is, the value in the index registers can, by means of a single instruction, be increased or decreased by the number one. They are, therefore, useful in accessing successive table locations, moving memory, and counting loop iterations. Unlike the accumulator, no logical or arithmetic operations (other than incrementing, decrementing, and comparing) may be performed upon them.

The use of indexing allows easy access to continuous series of memory locations, such as a multiple-byte objects. Indexing is performed by adding one of several forms of base addresses, specified in the operand field of an instruction, to the contents of an index register. While a constant operand is fixed when a program is created, the index registers are variable and their contents can be changed readily during the execution of a program. As a result, indexing provides an extremely flexible mechanism for accessing data in memory.

Although the X and Y index registers are basically similar, their capabilities are not identical. Certain instructions and addressing modes work only with one or the other of these registers. The **indirect indexed** addressing modes require the Y register. And while the X is primarily used with **direct page indexed** and **absolute indexed** addressing, it has its own unique (though infrequently used) **indexed indirect** addressing mode. These differences will become clear as you learn more about the different addressing modes.

### *The Status Register*

The status register (also called the **P** register, for **processor status**) contains a number of **flags** which describe, in part, the status of the microprocessor and its operations. A flag is, in this case, a single bit within the status register. Its value, set (a **one**) or reset (a **zero**), indicates one of two conditions. While the 6502's eight-bit status register could provide eight one-bit flags, only seven of them are used.

Figure 2.1 showed the 6502 **P** status register; Tables 2.1 and 2.2 describe the functions of its flags.

Table 2.1 describes the five status register **condition code** flags – **negative**, **zero**, **overflow**, **carry**, and **break**. Their values indicate various conditions that result from the execution of many 6502 instructions. Some instructions affect none of the condition code flags, others affect only some, and still others affect all. The effect that an instruction has on the condition flags is an important part of describing what the instruction does. These condition code flags are used to determine the success or failure of the **branch on condition** instructions.

Notice particularly the zero flag (z). It can sometimes confuse assembly programmers because a zero flag setting of one indicates a zero result while a zero flag setting of zero indicates a non-zero result.

<i>Name</i>	<i>Abbrev</i>	<i>Bit</i>	<i>Explicitly set or clear</i>	<i>Set or cleared to Reflect an operation result</i>
negative	n	7	-	Reflects most significant bit results (the sign of a two's-complement binary number): 0= High bit clear (positive result) 1= high bit set (negative result)
zero	z	1	-	Indicates zero or non-zero results: 0= non-zero result 1- zero result
overflow	v	6	Clear to reverse "set-overflow" hardware input	Indicates invalid carry into high bit of arithmetic result (two's-complement overflow): 0= two's-complement result ok 1= error if two's-complement arithmetic
carry	c	0	Clear before starting addition Set before starting subtraction	Arithmetic overflow: addition: carry out of high bit: 0= no carry 1= carry subtraction: borrow required to subtract: 0= borrow required 1= no borrow required Logic: receives bit shifted or rotated out; source of bit rotated in
break	b	4		Status register itself: no function; value unknown. Pushed status register after interrupt: indicates source of interrupt: 0= hardware interrupt 1= software interrupt (BRK) instruction)

**Table 2-1 Status Register Condition Code Flags**

In connection with the carry flag, it is important to know that the 6502 add operation has been designed to always add in the carry, and the subtract operation to always use the carry as a borrow flag, making it possible to do multiple-precision arithmetic where you add successively higher sets of bytes plus the previous adds carry or subtract successfully higher sets of bytes taking into the operation that previous subtract's borrow. The drawback to this scheme is that the carry must be zeroed before starting an add and set before starting a subtraction.

In the case of subtraction, the 6502's carry flag is an inverted borrow, unlike that of most other microprocessors. If a borrow occurred during the last operation, it is cleared; if a borrow did not result, it is set.

Finally, notice that in the status register itself, the break bit has no function. Only when an interrupt pushes the status register onto the stack is the break bit either cleared or set to indicate the type of interrupt responsible.

Table 2.2 describes the other two P register flags, the **mode select** flags: by explicitly setting or clearing them, you can change the operational modes of the processor.

<i>Name</i>	<i>Abbrev</i>	<i>Bit</i>	<i>Reason to explicitly set or clear</i>
decimal	d	3	Determines mode for add & subtract (not increment/decrement, through): Set to force decimal operations (BCD) Clear to return to binary operation
interrupt	i	2	Enables or disables processor's IRQ interrupt line: Set to disable interrupts by masking the IRQ line Clear to enable IRQ interrupts

**Table 2-2 Status Register Mode Select Flags**

The **decimal mode** flag toggles add and subtract operations (but *not* increment or decrement instructions) between binary and decimal (BCD). Most processors require a separate decimal-adjust operation after numbers represented in decimal format have been added or subtracted. The 65x processors do on-the-fly decimal adjustment when the decimal flag is set.

The **IRQ disable** or **interrupt disable** flag, toggles between enabling and disabling interrupts. Typically, the interrupt mask is set during time-critical loops, during certain I/O operations, and while servicing another interrupt.

### ***The Stack Pointer***

The stack pointer (**S**) implements directly in hardware a data structure known as a **stack** or **push-down stack**. The stack is a dedicated area of memory which is accessed by the user via push and pull instructions. Push stores the contents of a register onto the stack; pull retrieves a data item from the stack, storing it into a register.

The 6502's stack is limited to 256 bytes by the eight-bit width of its stack pointer. The chip confines it in memory between \$100 and \$1FF by fixing the high-order byte of the stack address at \$01. Software power-up routines generally initialize the 6502 stack pointer to \$FF, resulting in an initial stack location of \$1FF (*see* Figure 2.2).

The push and pull instructions are one-byte instructions: the instruction itself specifies the register affected and the value in the stack pointer register, added to \$100, specifies the stack memory location to be accessed.

When a push instruction is executed, data is moved from the register specified by the instructions opcode to the stack address pointed to by the stack pointer. As Figure 2.3 shows, the value in the stack pointer is then decremented so that it points to the next memory location – the location to which the next push instruction encountered will store its data.

The pull instruction reverses the process and retrieves data from the stack. When a pull instruction is executed, first the stack pointer is incremented, the register specified in the instruction opcode is loaded with the data at the incremented address point to by SP.

**Initializing the Stack Pointer to \$FF:  
Resulting Initial Stack of \$1FF**

Stack Pointer = \$FF

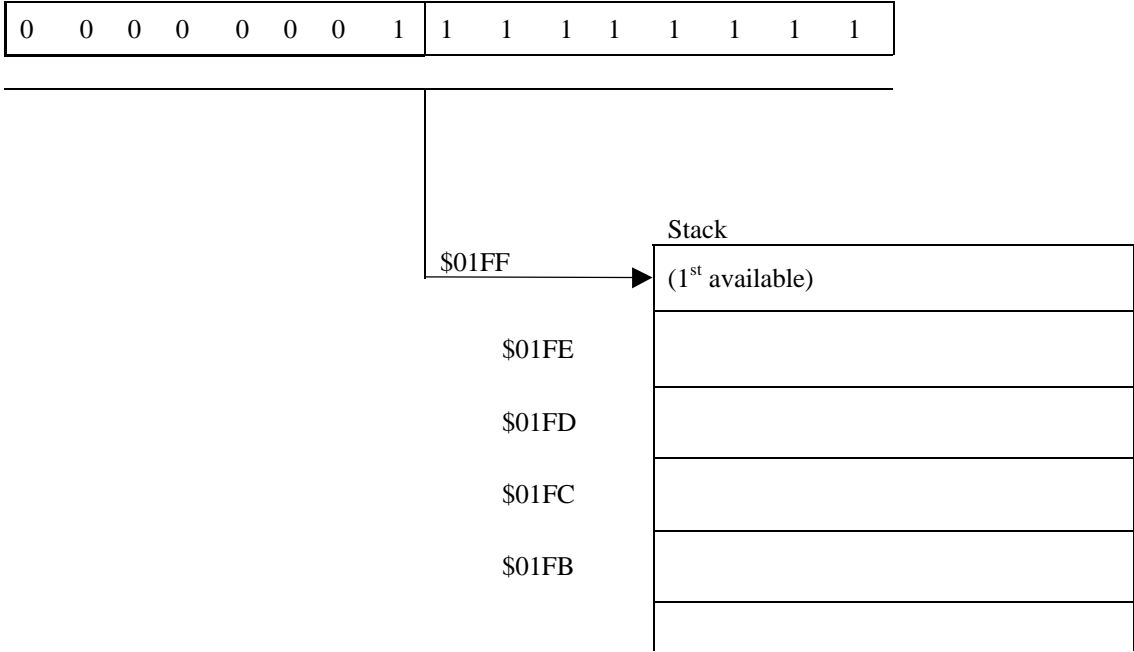

**Figure 2-2 Initializing the Stack Pointer to \$FF**

In addition to being available as a temporary storage area, the stack is also used by the system itself in processing interrupts, subroutine calls, and returns. When a subroutine is called the current value of the program counter is pushed automatically onto the stack; the processor executes a return instruction by reloading the program counter with the value on the top of the stack.

While data is pushed into subsequently lower memory locations on the 65x stacks, the location of the last data pushed is nonetheless referred to as the top of the stack.



## The Western Design Center

After Pushing the Accumulator

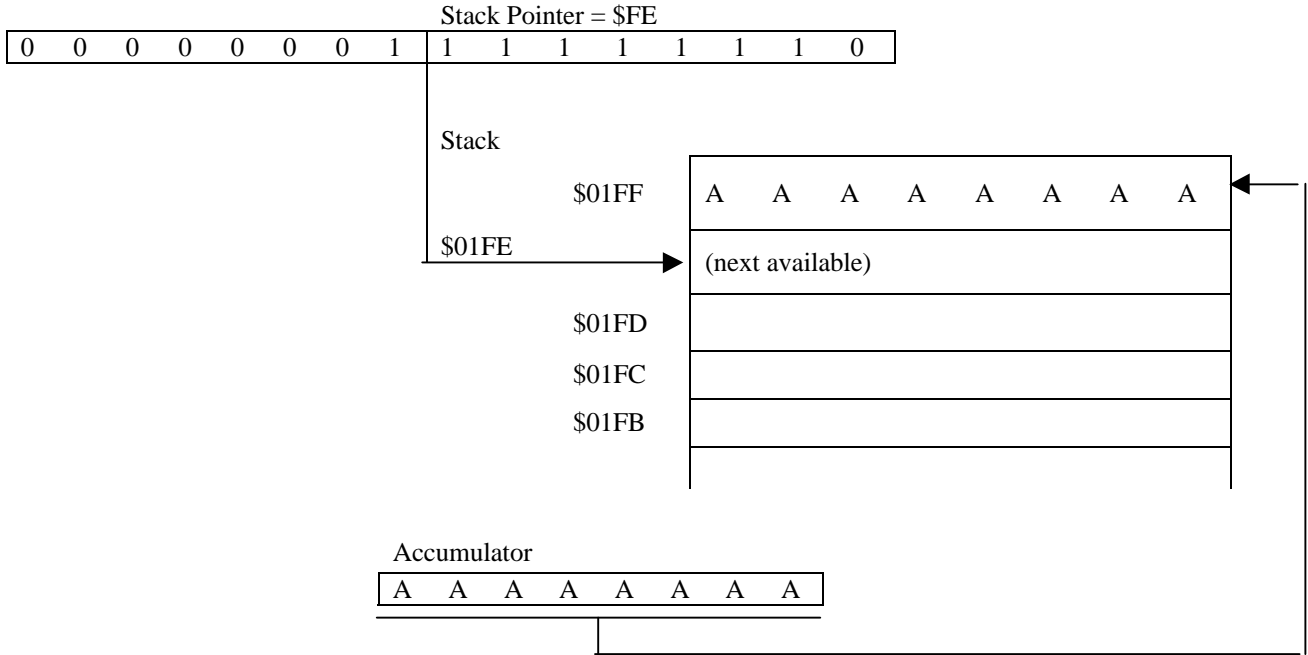

Figure 2-3 After Pushing the Accumulator

### The Program Counter

The program counter (PC) contains the address of the next byte in the instruction stream to fetch. Execution of a program begins when the program counter is set to the program's entry point (typically the address at which it is loaded). The processor fetches an instruction opcode from location, and proceeds to execute it. Based on the given opcode, the processor will need to fetch zero, one, or two bytes of operand from the successive locations following the instruction. When the operand has been fetched, the instruction is executed. The program counter is normally incremented to point to the next instruction in memory, except in the case of jump, branch, and call instructions, which pass control to a new location within the program by storing the new location to the program counter.

The 6502 program counter is sixteen bits wide, allowing for programs of up to 64K byte. If the program counter is still incremented past \$FFFF, it wraps around to \$0000.

### Addressing Modes

The fourteen different addressing modes that may be used with the 6502 are shown in Table 2.3. The availability of this many different addressing modes on the 6502 gives it much of its power: Each one allows a given instruction to specify its effective address – the source of the data it will reference – in a different manner.

Not all addressing modes are available for all instructions; but each instruction provides a separate opcode for each of the addressing modes its supports.

Addressing Mode	Syntax Example	
	Opcode	Operand
Implied	DEX	
Accumulator	ASL	A
Immediate	LDA	#55
Absolute	LDA	\$2000
Program Counter Relative	BEQ	LABEL12
Stack	PHA	
Zero Stack	LDA	\$81
Absolute Indexed with X	LDA	\$2000,X
Absolute Indexed with Y	LDA	\$2000,Y
Zero Page Indexed with X	LDA	\$55,X
Zero Page Indexed with Y	LDX	\$55,Y
Absolute Indirect	JMP	(\$1020)
Zero Page Indirect Indexed with Y (Postindexed)	LDA	(\$55),Y
Zero Page Indexed Indirect with X (Preindexed)	LDA	(\$55,X)

**Table 2-3 6502 Addressing Modes**

For some of the 6502 addressing modes, the entire effective address is provided in the operand field of the instruction; for many of them, however, formation of the effective address involves an address calculation, that is, the addition of two or more values. The addressing mode indicates where these values are to come from and how they are to be added together to form the effective address.

**Implied addressing** instructions, such as **DEY** and **INX**, need no operands. The register that is the source of the data is named in the instruction mnemonic and is specified to the processor by the opcode. **Accumulator addressing**, in which data to be referenced is in the accumulator, is specified to the assembler by the operand **A**. **Immediate addressing**, used to access data which is constant throughout the execution of a program, causes the assembler to store the data right into the instruction stream. **Relative addressing** provides the means for conditional branch instructions to require only two bytes, one byte less than jump instructions take. The one-byte operand following the branch instruction is an offset from the current contents of the program counter. **Stack addressing** encompasses all instructions, such as push or pull instructions, which use the stack pointer register to access memory. And **absolute addressing** allows data in memory to be accessed by means of its address.

Like the 6800 processor, the 6502 treats the zero page of memory specially. A **page** of memory is an address range \$100 bytes (256 decimal) long: the high bytes of the addresses in a given page are all the same, while the low bytes run from \$00 through \$FF. The **zero page** is the first page of memory, from \$0000 through \$00FF (the high byte of each address in the zero page is zero). **Zero page addressing**, a short form of absolute addressing, allows zero page operands to be referenced by just one byte, the lower-order byte, resulting both in fewer code bytes and in fewer clock cycles.

While most other processors provide for some form of **indexing**, the 6502 provides some of the broadest indexing possibilities. Indexed effective addresses are formed from the addition of a specified base address and index, as shown in Figure 2.4. Because the 6502's index registers (X and Y) can hold only eight bits, they are seldom used to hold index bases; rather, they are almost always used to hold the indexes themselves. The 6502's four simplest indexing modes add the contents of the X or Y register to an absolute or zero page base.

**Indirection** (Figure 2.5) is less commonly found in microprocessor repertoires, particularly among those microprocessors of the same design generation as the 6502. It lets the operand specify an address at which another address, the **indirect address**, can be found. It is at this second address that data will be referenced. The 6502 not only provides indirection for its jump instruction, allowing jumps to be vectored and revectorred, but it also combines indirection with indexing to give it real power in accessing data. It's as though the storage cells for the indirect addresses are additional 6502 registers, massively extending the 6502's register set and possibilities. In one addressing mode, indexing is performed before indirection; in another, after. The first provides indexing into an array of indirect addresses and the second provides indexing into array which is located by the indirect address.

The full set of 65x addressing modes are explained in detail in Chapters 7 and 11 and are reviewed in the Reference Section

**Indexing: Base plus Index**

For example

Base = \$2000  
 Index Register X = \$ 03  
 Effective Address = \$2003

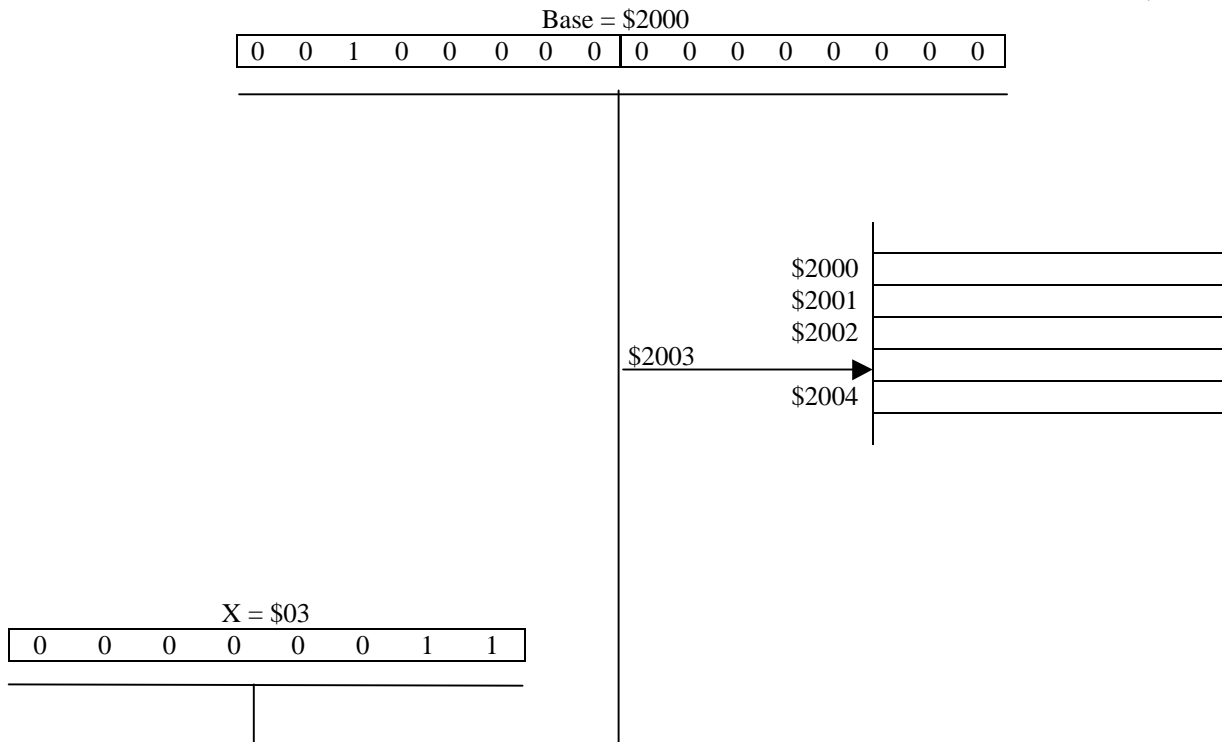

**Figure 2-4 Indexing: Base Plus Index**

**Instructions**

The 6502 has 56 operation mnemonics, as listed in Table 2.4, which combine with its many addressing modes to make 151 instructions available to 6502 programmers.

Arithmetic instructions are available, including comparisons, increment, and decrement. But missing are addition or subtraction instructions which do not involve the carry; as a result, you must clear the carry before beginning an add and set it before beginning subtraction.

**Indirection: Operand Locates Indirect Address**

For Example: Zero Page Operand = \$20  
Data at \$20.21 (Indirect Address) = \$3458  
Effective Address = \$3458

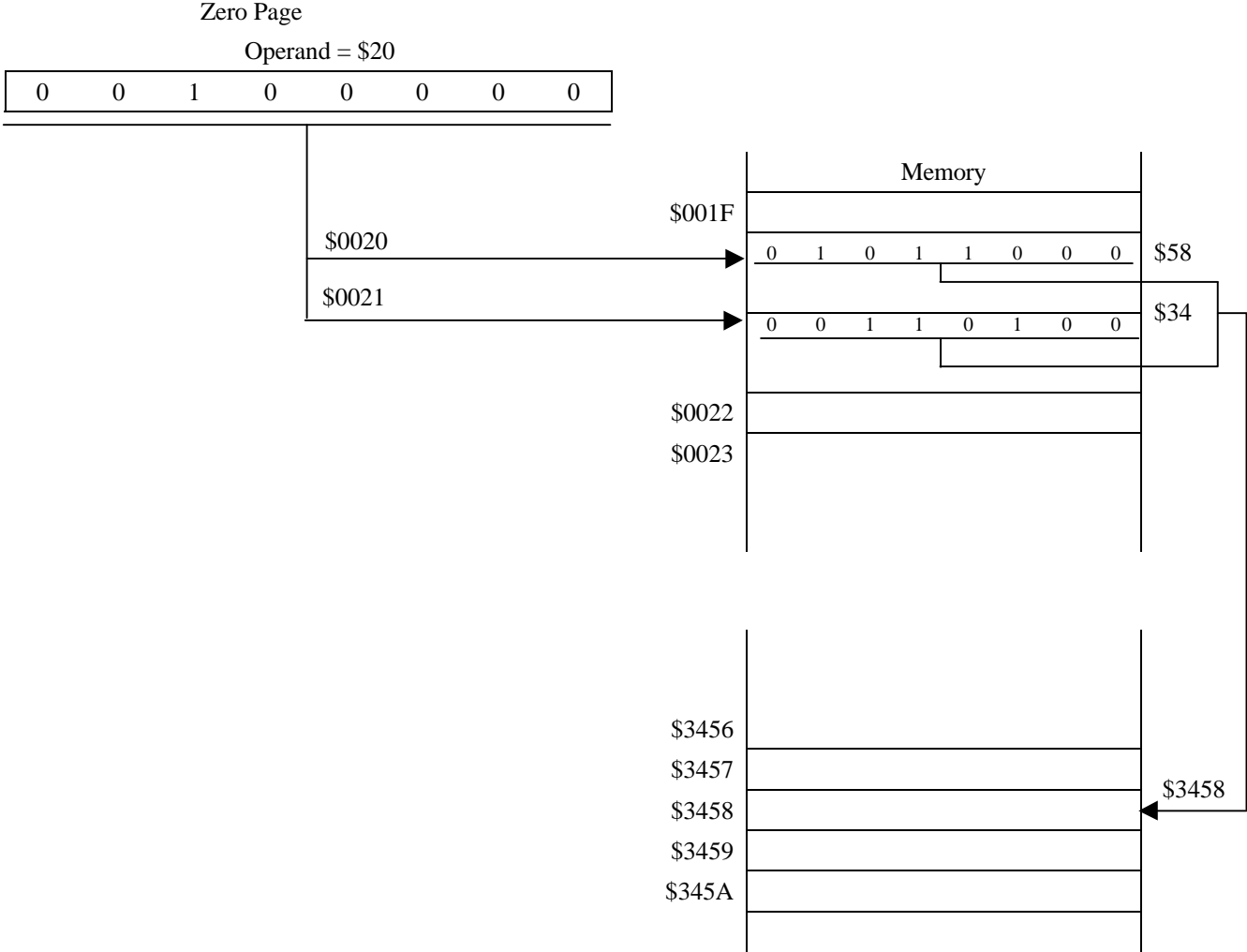

**Figure 2-5 Indirection: Operand Locates Indirect Address**

<i>Instruction Mnemonic</i>	<i>Description</i>
ADC	Add memory and carry to accumulator
AND	And accumulator with memory
ASL	Shift memory or accumulator left one bit
BCC	Branch if carry clear
BCS	Branch if carry set
BEQ	Branch if equal
BIT	Test memory bits against accumulator
BNE	Branch if negative
BPL	Branch if not equal
BRK	Branch if plus Software break (interrupt)
BVC	Branch if overflow clear
BVS	Branch if overflow set
CLC	Clear carry flag
CLD	Clear decimal mode flag
CLI	Clear interrupt-disable flag
CLV	Clear overflow flag
CMP	Compare accumulator with memory
CPX	Compare index register X with memory
CPY	Compare index register Y with memory
DEC	Decrement
DEX	Decrement index register X
DEY	Decrement index register Y
EOR	Exclusive-OR accumulator with memory
INC	Increment
INX	Increment index register X
INY	Increment index register Y
JMP	Jump
JSR	Jump to subroutine
LDA	Load accumulator from memory
LDX	Load index register X from memory
LDY	Load index register Y from memory
LSR	Logical shift memory or accumulator right
NOP	No operation
ORA	OR accumulator with memory
PHA	Push accumulator onto stack
PHP	Push status flags onto stack
PLA	Pull accumulator from stack
PLP	Pull status flags from stack
ROL	Rotate memory or accumulator left one bit
ROR	Rotate memory or accumulator right one bit
RTI	Return from interrupt
RTS	Return from subroutine
SBC	Subtract memory with borrow from accumulator
SEC	Set carry flag
SED	Set decimal mode flag
SEI	Set interrupt-disable flag
STA	Store accumulator to memory
STX	Store index register X to memory
STY	Store index register Y to memory
TAX	Transfer accumulator to index register X
TAY	Transfer accumulator to index register Y
TSX	Transfer stacker point to index register X
TXA	Transfer index register X to accumulator
TXS	Transfer index register X to stack pointer
TYA	Transfer index register Y to accumulator

**Table 2-4 6502 Instructions**

## The Western Design Center

Logic instructions available include shifts and rotates, as well as an instruction for bit comparing.

Branch instructions are entirely flag-based, not arithmetic-operation based, so there are no single branch-on-greater-than, branch-on-less-than-or-equal, or signed arithmetic branches. There is also no unconditional branch and no branch-to-subroutine. The unconditional branch can be imitated by first executing one of the 6502's many clear- or set- flag instructions, then executing a branch-on-the-flag's-condition instruction.

All three of the main user registers can be loaded from and stored to memory, but only the accumulator (not the index register) can be pushed onto and pulled from the stack (although the flags can also be pushed and pulled). On the other hand, single instructions let the accumulator value be transferred to either index register or loaded from either index register. One more transfer instruction is provided for setting the value of the stack pointer to the value in the X index register.

## The 6502 System Design

There are a number of other features of the 6502's design which make it unique and make systems designed with it stand apart from systems designed with other microprocessors.

### *Pipelining*

The 65x microprocessors have the capability of doing two things at once: the 6502 can be carrying on an internal activity (like an arithmetic or logical operation) even as it's getting the next instruction byte from the instruction stream or accessing data in memory.

A processor is driven by a **clock** signal which synchronizes events within the processor with memory accesses. A cycle is a basic unit of time within which a single step of an operation can be performed. The speed with which an instruction can be executed is expressed in the number of cycles required to complete it. The actual speed of execution is a function both of the number of cycles required for completion and the number of timing signals provided by the clock every second. Typical clock values for 65x processors start at one million cycles per second and go up from there.

As a result of the 6502's capability of performing two different but overlapping phases of a task within a single cycle, which is called **pipelining**, the 65x processors are much faster than non- pipelined processors.

Take the addition of a constant to the 6502's eight-bit accumulator as an example. This requires five distinct steps:

- Step 1: Fetch the instruction opcode ADC.
- Step 2: Interpret the opcode to be ADC of a constant.
- Step 3: Fetch the operand, the constant to be added.
- Step 4: Add the constant to the accumulator contents.
- Step 5: Store the result back to the accumulator.

Pipelining allows the 6502 to execute steps two and three in a single cycle: after getting an opcode, it increments the program counter, puts the new program address onto the address bus, and gets the next program byte, while simultaneously interpreting the opcode. The completion of steps four and five overlaps the next instruction's step one, eliminating the need for two additional cycles.

So the 6502's pipelining reduces the operation of adding a constant from five cycles to two!

The clock speed of a microprocessor has often been incorrectly presumed to be the sole determinant of its speed. What is most significant, however, is the memory cycle time. The 68000, for example, which typically operates at 6 to 12 megahertz (MHz, or millions of cycles per second) requires four clock periods to read or write data to and from memory. The 65x processors require only one clock period. Because the 6502 requires fewer machine cycles to perform the same functions, a one-megahertz 6502 has a throughput unmatched by the 8080 and Z80 processors until their clock rates are up to about four MHz.

The true measure of the relative speeds of various microprocessors can only be made by comparing how long each takes, in its own machine code, to complete the same operation.

## The Western Design Center

### *Memory Order of Multiple-Byte Values*

Multiple-byte values could be stored in memory in one of two ways: low-order byte first, followed by successively high order bytes; or high-order bytes first, followed by successively lower order bytes. The 6502, like the Intel and Zilog chip (the 8080, Z80, 8086, and so on), but unlike the Motorola chips (the 6800, 6809, 68000, and so on), puts the low-order byte first, into the lower memory address.

This seemingly unnatural order of the placement of multiple-byte values in memory as a \$30 followed by \$FE is not \$30FE but rather \$FE30. Multiple-byte values are written high-order first, to read from left to right; this is the opposite of how the bytes are placed in memory. This memory order, however, contributes to the success and speed of pipelining. Consider, as an example, the loading of the accumulator using absolute indexed addressing (two lines for a cycle indicate simultaneous operations due to pipelining):

- Cycle 1:Fetch the instruction opcode, LDA.
- Cycle 2:Fetch the operand byte, the low byte of an array base.  
Interpret the opcode to be LDA absolute indexed.
- Cycle 3:Fetch the second operand byte, the high array base byte.  
Add the contents of the index register to the low byte.
- Cycle 4:Add the carry from the low address add to the high byte.
- Cycle 5:Fetch the byte at the new effective memory address.

(NOTE: The 6502 also does a fetch during Cycle 4, before it checks to see if there was any carry; if there is no carry into the high byte of the address, as is often true, then the address fetched from was correct and there is no cycle five; the operation is a four-cycle operation in this case. Absolute indexed writes, however, always require five cycles.)

The low-high memory order means that the first operand byte, which the 6502 fetches before it even knows that the opcode is **LDA** and the addressing mode is absolute indexed, is the low byte of the address base, the byte which must be added to the index register value first; it can do that add while getting the high-byte.

Consider how high-low memory order would weaken the benefits of pipelining and slow the process down:

- Cycle 1:Fetch the instruction opcode, LDA.
- Cycle 2:Fetch an operand byte, the high byte of an array base.  
Interpret the opcode to be LDA absolute indexed.
- Cycle 3:Fetch the second operand byte, the low array base byte.  
Store the high byte temporarily.
- Cycle 4:Add the contents of the index register to the low byte.
- Cycle 5:Add the carry from the low address add to the high byte.
- Cycle 6:Fetch the byte at the new effective memory address.

### *Memory-Mapped Input/Output*

The 65x family (like Motorola's but unlike Zilog's and Intel's) accomplishes input and output not with special opcodes, but by assigning each input/output device a memory location, and by reading from or writing to that location. As a result, there's virtually no limit to the number of I/O devices which may be connected to a 65x system. The disadvantage of this method is that memory in a system is reduced by the number of locations which are set for I/O functions.

### *Interrupts*

**Interrupts** tell the processor to stop what it is doing and to take care of some more pressing matter instead, before returning to where it left off in regular program code. An interrupt is much like a doorbell: having one means you don't have to keep going to the door every few minutes to see if someone is there; you can wait for it to ring instead.

An external device like a keyboard, for example, might cause an interrupt to present input. Or a clock might generate interrupts to toggle the processor back and forth between two or more routines, letting it do several tasks "at once." A special kind of interrupt is **reset** (the panic button), which is generally used out of

## The Western Design Center

frustration to force the processor into re-initialization. Reset generally does not return to the interrupted code after it has been served, however.

The 6502 has three **interrupt vectors** – memory addresses that hold the locations of routines which are automatically executed upon recognition of an interrupt by the processor. The first of these is used for reset.

The second vector is used both by **maskable interrupts** – those which you can force the processor to ignore, either temporarily or permanently, by setting the **i** interrupt bit in the status register - and by **software interrupts** - which are caused by the execution of the break instruction (**BRK**). If any hardware can cause a maskable interrupt, the **interrupt service routine** pointed to by this vector must still determine the source of the interrupt. It must poll a status flag on each possible hardware source as well as check the stacked register's **b** flag, which is set and pushed when a break instruction is executed. When it finds the source of the interrupt, it must then branch to a routine which will respond to the interrupt in a way appropriate to the source (getting a character from a communications port, for example).

The third vector is used by **nonmaskable interrupts**, those which interrupt regardless of the **i** bit in the status register. The non-maskable interrupt is usually reserved for a single high-priority or time-critical interrupt, such as refresh of a CRT screen or to warn of impending power failure.

The 6502 was designed to service interrupts as fast as possible. Because interrupts cannot be served until the current instruction is completed (so no data is lost), the worst case is the longest instruction time and the 6502's instructions each take very few cycles to execute. As a result, the 6502 and its successors have the lowest interrupt **latency** – the time between interrupt occurrence and interrupt-handling response – of any eight-bit or sixteen-bit processors.

## NMOS Process

The 6502 is fabricated using the **NMOS** (pronounced “EN moss”) process (for N-channel Metal-Oxide Semiconductor). Still one of the most common of the technologies used in large-scale and very-large-scale integrated circuits, NMOS was, at the time the 6502 was designed and for many years after, the most cost-efficient of the MOS technologies and the easiest process for implementation of relatively high-speed parts. This made NMOS popular among designers of microcomputers and other devices in which hardware was an important design factor.

Most of the current generation of 8-, 16-, and 32-bit processors were originally implemented in NMOS. Some, like the 6502, are still only available in NMOS process versions. Others, like all of the recently designed members of the 65x family (65C02, 65802, and 65816) were produced exclusively using the CMOS process.

## Bugs and Quirks

The 6502 has a number of features which the less enthusiastic might be inclined to call bugs or quirks.

The one most clearly a bug involves using indirect addressing with the jump instruction, when its operand ends in \$FF. To use an example,

JMP (\$20FF)

should cause the program counter to get, as its new low byte, the contents of \$20FF, and as its new high byte, the contents of \$2100. However, while the 6502 increments the low byte of the indirect address from \$FF to 00, it fails to add the carry into the high byte, and as a result gets the program counter's new high byte from \$2000 rather than \$2100.

You can also run into trouble trying to execute an unused opcode, of which the 6502 has many. The results are unpredictable, but can include causing the processor to “hang”.

Finally, the decimal mode is not as easy to use as it might be. The negative, overflow, and zero flags in the status register are not valid in decimal mode and the setting of the decimal flag, which toggles the processor between binary and decimal math, is unknown after the processor has received a hardware “reset”.



## 3) Chapter Three

### Architecture of the 65C02

The 65C02 microprocessor is an enhanced version of the 6502, implemented using a silicon-gate CMOS process. The 65C02 was designed primarily as a CMOS replacement for the 6502. As a result, the significant differences between the two products are few. While the 65C02 adds 27 new opcodes and two new addressing modes (in addition to implementing the original 151 opcodes of the 6502), its register set, memory model, and types of operations remain the same.

The 65C02 is used in the AppleIIc and, since early 1985, in the AppleIIe, and it has been provided as an enhancement kit for earlier IIe's.

Remember that even as the 65C02 is a superset of the 6502, the 65802 and 65816, described in the next chapter, are supersets of the 65C02. All of the enhancements found in the 65C02 are additionally significant in that they are intermediate to the full 65816 architecture. The next chapter will continue to borrow from the material covered in the previous ones, and generally what is covered in the earlier of these three architecture chapters is not repeated in the subsequent ones, since it is true for *all* 65x processors.

### The 65C02 Architecture

Both the 65C02 and the 6502 are eight-bit processors, with a 64K address space and exactly the same register set.

The 65C02 features some small but highly desirable improvements in the use of the status register flags: it gives valid negative, overflow, and zero flags while in decimal mode, unlike the 6502; and it resets the decimal flag to zero after reset and interrupt.

The 65C02 has slightly different cycle counts on a number of operations from the 6502, some shorter and a few longer. The longer cycle counts are generally necessary to correct or improve operations from the 6502.

### Addressing Modes

The 65C02 introduces the two new addressing modes shown in table 3.1, as well as supporting all the 6502 addressing modes. All of them will be explained in detail in Chapters 7 and 11, and will be reviewed in the Reference Section.

<i>Addressing Mode</i>	<i>Syntax</i>	<i>Example</i>
	<i>Opcode</i>	<i>Operand</i>
Zero Page Indirect	LDA	(\$55)
Absolute Indexed Indirect	JMP	(\$2000,X)

**Table 3-1 The 65C02's New Addressing Modes.**

**Zero page indirect** provides an indirect addressing mode for accessing data which requires no indexing (the 6502's absolute indirect mode is available only to the jump instructions). 6502 programmers commonly simulate indirection by loading an index register with zero (losing its contents and taking extra steps), then using the preindexed or postindexed addressing modes to indirectly reference the data.

On the other hand, combining indexing and indirection proved so powerful for accessing data on the 6502 that programmers wanted to see this combination made available for tables of jump vectors. **Absolute indexed indirect**, available for jump instruction only, provides this multi-directional branching capability, which can be very useful for *case* or *switch* statements common to many languages.

## Instructions

While the 65C02 provides 27 new opcodes, there are only eight new operations. The 27 opcodes result from providing four different addressing modes for one on the new mnemonics and two for two others, and also from expanding the addressing modes for twelve 6502 instructions. The most significant expansion of a 6502 instruction by combining it with a 6502 addressing mode it did not previously use is probably the addition of accumulator addressing for the increment and decrement instructions.

The new 65C02 operations, shown in Table 3.2, answer many programmer's prayers: an unconditional branch instruction, instructions to push and pull the index registers, and instructions to zero out memory cells. These may be small enhancements, but they make programming the 65C02 easier, more straightforward, and clearer to document. Two more operations allow the 65C02 to set or clear any or all of the bits in a memory cell with a single instruction.

Instruction Mnemonic	Description
BRA	Branch always (unconditional)
PHX	Push index register X onto stack
PHY	Push index register Y onto stack
PLX	Pull index register X from stack
PLY	Pull index register Y from stack
STZ	Store zero to memory
TRB	Test and reset memory bits against accumulator
TSB	Test and set memory bits against accumulator

Table 3-2. New 65C02 Instructions

## CMOS Process

Unlike the 6502, which is fabricated in NMOS, the 65C02 is a CMOS (pronounced "SEE moss") part. CMOS stands for Complementary Metal-Oxide Semiconductor.

The most exciting feature of CMOS is its low power consumption, which has made portable, battery-operated computers possible. Its low power needs also result in lower heat generation, which means parts can be placed closer together and heat-dissipating air space minimized in CMOS-based computer designs.

CMOS technology is not a new process. It's been around for about as long as other MOS technologies. But higher manufacturing costs during the early days of the technology made CMOS impractical for the highly competitive microcomputer market until the mid 1980s, so process development efforts were concentrated on NMOS and not applied to CMOS until 1980 or 1981.

CMOS technology has reached a new threshold in that most of its negative qualities, such as the difficulty with which smaller geometries are achieved relative to the NMOS process, have been overcome. Price has become competitive with the more established NMOS as well.

## Bugs and Quirks

The 65C02 fixes all of the known bugs and quirks in the 6502. The result of executing unused opcodes is now predictable—they do nothing (that is, they act like no-operation instructions). An interesting footnote is that, depending on the unimplemented instruction that is executed, the number of cycles consumed by the no-operation is variable between one and eight cycles. Also, the number of bytes the program counter is incremented by is variable. It is strongly recommended that this feature not be exploited, as its use will produce code incompatible with the next-generation 65802 and 65816.

The jump indirect instruction has been fixed to work correctly when its operand crosses a page boundary (although at the cost of an execution cycle). The negative overflow, and zero flags have been implemented to work in decimal mode (also at the cost of an execution cycle). The decimal mode is now reset to binary after a hardware reset or an interrupt.

## **The Western Design Center**

Finally, a fix which is generally transparent to the programmer, but which eliminates a possible cause of interference with memory-mapped I/O devices on the 6502, is the elimination of an invalid address read while generating an indexed effective address when a page boundary is crossed.

The quirk unique to the 65C02 results from trying to eliminate the quirks of the 6502. The timing improvements of a number of instructions and the bug fixes from the 6502 make the 65c02 an improvement over the 6502, but not quite fully compatible on a cycle-by-cycle basis. This is only a consideration during the execution of time-critical code, such as software timing loops. As a practical example, this has affected very little software being ported from the Apple IIe to the IIc.

## 4) Chapter Four

### Sixteen-Bit Architecture The 65816 and the 65802

While the 65C02 was designed more as a CMOS replacement for the 6502 than an enhancement of it, the 65802 and 65816 were created to move the earlier designs into the world of sixteen-bit processing. Although the eight-bit 6502 had been a speed demon when first released, its competition changed over the years as processing sixteen bits at a time became common, and as the memory new processors could address started at a megabyte.

The 65816 and the 65802 were designed to bring the 65x family into line with the current generation of advanced processors. First produced in prototypes in the second half of 1984, they were released simultaneously early in 1985. The 65816 is a full-featured realization of the 65x concept as a sixteen-bit machine. The 65802 is its little brother, with the 65816's sixteen-bit processing packaged with the 6502's pinout for compatibility with existing hardware.

The two processors are quite similar. They are, in fact, two different versions of the same basic design. In the early stages of the chip fabrication process they are identical and only assume their distinct "personalities" during the final (metalization) phase of manufacture.

The two processors provide a wealth of enhancements: another nine addressing modes, 78 new opcodes, a "hidden" second accumulator in eight-bit mode, and zero page which, renamed the **direct page**, can be relocated to any contiguous set of 100 bytes anywhere within the first 64K of memory (which in the case of the 65802 is anywhere in its address space). The most dramatic of all the enhancements common to both 65802 and 65816, though, is the expansion of the primary user registers – the accumulator, index register, and stack pointer – to sixteen-bit word size. The accumulator and index registers can be toggled to sixteen bits from eight, and back to eight when needed. The stack, pointed to by an expanded-to-sixteen-bit stack register, can be relocated from page one to anywhere in a 64K range.

The primary distinction between the two processors is the range of addressable memory: the 65816 can address up to sixteen megabytes; the 65802 is constrained by its 6502 pinout to 64K.

A secondary distinction between the two processors is that the 65816's new pinout also provides several significant new signals for the hardware designer. While outside the primary scope of this book, these new signals are mentioned in part in this chapter and described in some detail in Appendix C.

It is important to remember that the 65802 is in fact a 65816 that has been coerced to live in the environment designed originally for the 6502 and 65C02. Outside of the memory and signal distinctions just listed, the 65816 and the 65802 are identical. Both have a **native mode**, in which their registers can be used for either eight- or sixteen-bit operations. Both have a 6502 **emulation mode**, in which the 6502's register set and instruction timings emulate the eight-bit 6502 (not the 65C02) *exactly* (except they correct a few 6502 bugs). *All* existing 6502 software can be run by the new processor – as can virtually all 65C02 software – even as most of the native mode's enhancements (other than sixteen-bit register) are programmable in emulation mode, too.

To access sixteen megabytes, the signals assigned to the various pins of the 65816's 40-pin package are different from the 6502, and the 65C02 and the 65802, so it cannot be installed in existing 65x computers as a replacement upgrade. The 65802, on the other hand, has a pinout that is identical to that of the 6502 and 65C02 and can indeed be used as a replacement upgrade.

This makes the 65802 a unique, pin-compatible, software-compatible sixteen-bit upgrade chip. You can pull a 6502 out of its socket in any existing 6502 system, and replace it with a 65802 because it powers-on in the 6502 emulation mode. It will run existing applications exactly the same as the 6502 did. Yet new software can be written, and 6502 programs rewritten, to take advantage of the 65802's sixteen-bit capabilities, resulting in programs which take up much less code space and which run faster. Unfortunately, even with a 65802 installed, an older system will remain unable to address memory beyond the original 64K limits of the 6502. This is the price of hardware compatibility.

The information presented in this chapter builds directly on the information in the previous two chapters; it should be considered as a continuous treatment of a single theme. Even in native mode with sixteen-bit registers, the 65802 and 65816 processors utilize many of the 6502 and 65C02 instructions, registers, and addressing modes in a manner which differs little from their use on the earlier processors. If you are

## The Western Design Center

already familiar with the 6502 or the 65C02, you will discover that the 65802 and 65816 logically expand on these earlier designs.

### Power-On Status: 6502 Emulation Mode

When the 65816 and 65802 are powered on, they initialize themselves into 6502 **emulation mode** in which, with the exception of fixing several 6502 bugs, they *exactly* emulate the 6502. The stack is confined to page one, just like the 6502 stack pointer. The registers are configured to eight bits, to model the 6502's registers. Every 6502 instruction is implemented identically. The timing of each instruction is exactly the same as on the original NMOS 6502. The direct page of the 65802 and 65816, which as you will learn can be relocated using the sixteen-bit direct page register, is initialized to page zero, making direct page addressing exactly equivalent to the 6502 zero page addressing. The program and data bank registers, which as you will learn provide efficient access in the 65816 to any one or two 64K banks of memory at a time, are initialized to the zero bank.

Unlike the NMOS 6502, which has undefined results when unimplemented opcodes are executed, and the 65C02, which treats unimplemented opcodes as variously-timed and -sized no-operations, the 65802 instruction set implements every one of the 256 possible one-byte opcodes. These additional instructions are available in emulation mode as well as in native mode.

Among the newly implemented opcodes are ones that allow the processors to be switched to their native mode – sixteen-bit operation. While there is more to say about 6502 emulation mode, it will be easier to understand in then context of native mode.

### The Full-Featured 65x Processor: The 65816 in Native Mode

The 65816 in its **native mode** (as opposed to its 6502 emulation mode) has it all: sixteen-bit registers, 24-bit addressing, and all the rest. The 65802's native mode is a subset of this, as are the emulation modes of both processors.

**65816 Native Mode Programming Model**  
**(16-bit accumulator & index register modes: m=0 & x=0)**

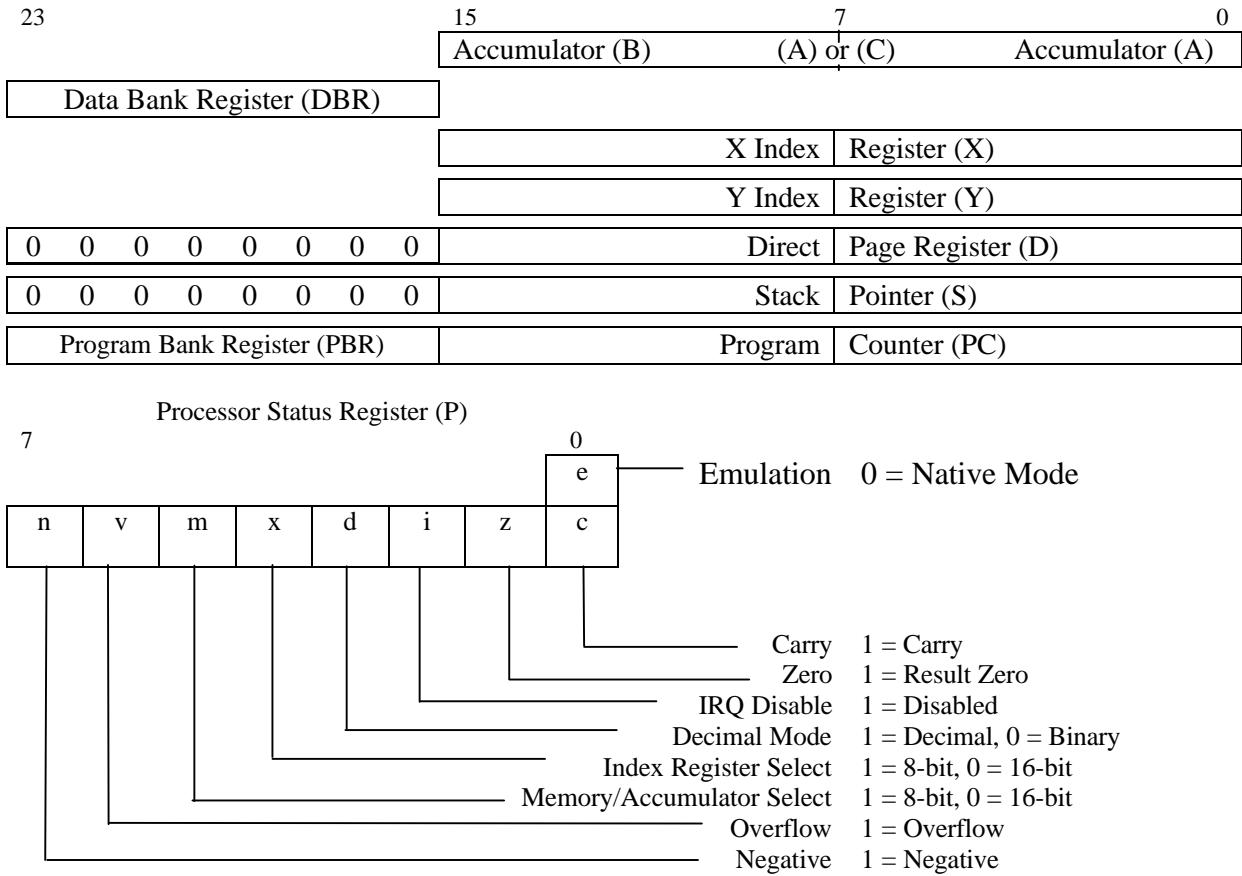

**Figure 4-1 65816 Native Mode Programming Model**

Figure 4.1 shows the programming model for the 65816 in native mode. While the accumulator is shown as a sixteen-bit register, it may be set to be either a single sixteen-bit accumulator (A or C) or two eight-bit accumulators, one accessible (A) and the other hidden but exchangeable (B). While the index registers are shown as sixteen-bit registers, they may be set, as a pair, to be either sixteen-bit registers or eight-bit registers – their high bytes are zeroed when they are set to eight-bits. The obvious advantage of switching from a processor with eight-bit registers to one with sixteen-bit registers is the ability to write programs which are from 25 to 50 percent shorter, and which run 25 to 50 percent faster due to the ease with which sixteen-bit data is manipulated.

The feature that most clearly distinguishes the current generation of advanced microcomputer systems, however, is the ability to address *lots* of memory. It is this increased memory addressability which has ushered in the new era of microcomputer applications possibilities, such as large spreadsheets, integrated software, multi-user systems, and more. In this regard, the 65816 stands on or above par with any of the other high-performance microprocessors, such as the 68000, the 8086, or their successors.

There are two new eight-bit registers called **bank registers**. One, called the **data bank register**, is shown placed above the index registers and the other, called the **program bank register**, is appended to the program counter. The 65816 uses the two bank registers to provide 24-bit addressing.

A **bank** of memory is much like a **page**; just as a page is a range of memory that can be defined by eight bits (256 bytes), a bank is a range of memory that can be defined by sixteen bits (64K bytes). For processors like the 6502, which have only sixteen-bit addressing, a 64K bank is not a relevant concept, since the only bank is the one being currently addressed. The 65816, on the other hand, partitions its memory range into 64K banks so that sixteen-bit registers and addressing modes can be used to address the entire range of memory.

## The Western Design Center

Bank zero, for example, is that 64K range for which, when addressed using 24 bits, the highest byte (also called the **bank byte**) is zero. Similarly, a highest byte of nine in a 24-bit address would address a location somewhere in bank nine. This highest byte is called the **bank byte** so that the **high byte** can still be used to refer to the byte that determines the page address. In other words, “high byte” is used on the 65816 as it is on the 6502, 65C02, and 65802, where addresses are only sixteen bits.

Another new register shown in Figure 4.1 is the **direct page register**. Much like the 6800’s special zero page became the 6809’s direct page, the 6502’s and 65C02’s zero page has been transformed into the 65802’s and 65816’s direct page. This direct page is, as Figure 4.1 shows, limited to bank zero, shown in the programming model by the implied zero as its bank byte. The direct page register can be set to any 256-byte page starting on any byte boundary within bank zero. All of the 6502 instructions that use zero page addressing use an expanded form called direct page addressing on the 65816 and 65802; however, when the direct page register value is zero, the two modes are operationally identical.

Figure 4.1 also shows that the stack pointer has been unbound from page one to float anywhere in bank zero by making it a sixteen-bit register.

While figure 4.1 doesn’t show the interrupt vectors, they too are located in bank zero, and they point to interrupt handling routines which also must be located in bank zero.

Finally, the status register is different from the 6502’s and 65C02’s (compare Figure 4.1 with Figure 2.1 in chapter 2). The first obvious difference is the single bit labeled **e** for emulation hanging off the top of the carry flag. Accessible only through the carry flag, its contents determine whether the processor is in native or 6502 emulation mode. Here it holds a zero to indicate the processor is in native mode. The second difference is the **m** and **x** flags replace the 6502’s break and unused flags: **m** indicates the size of the accumulator (eight or sixteen bits) as well as the size and memory accesses; **x** indicates the size of the two index registers (eight or sixteen bits). Changing the contents of either of these two new flags toggles the size of the corresponding registers. The **b** flag is no longer necessary to distinguish the **BRK** software interrupt from hardware interrupts because native mode provides a new interrupt vector for software interrupts, separate from the hardware interrupt vector.

Native mode also provides one timing improvement over the 6502: one cycle is saved during a cross-page branch.

## The Program Bank Register

The 65816’s sixteen-bit program counter is concatenated to its eight-bit program counter bank register (**PBR**, or **K** when used in instruction mnemonics) to extend its instruction-addressing capability to 24 bits. When the 65816 gets an instruction from memory, it gets it from the location pointed to by the concatenation of the two registers. In many ways, the net effect is a 24-bit program counter; for example, when an interrupt occurs, all 24 bits (program counter plus program counter bank) are pushed onto the stack. Likewise, when a return-from-interrupt occurs, 24 bits (both registers) are pulled from the stack.

All previous instructions that jumped to sixteen-bit absolute addresses still work by staying within the same bank. Relative branches stay in the same bank; that is, you can’t branch across bank boundaries. Program segments cannot cross bank boundaries; if the program counter increments past \$FFFF, it rolls over to \$0000 *without* incrementing the program counter bank.

New instructions and addressing modes were added to let you transfer control between banks: jump absolute long (jump to a specified 24-bit address), jump indirect long (the operand is an absolute address in bank zero pointing to a 24-bit address to which control is transferred), jump to subroutine long (to a specified 24-bit address, with the current program counter and program bank register pushed onto the stack first), and a corresponding return from subroutine long, which re-loads the bank register as well as the program counter. (The addressing modes are among those listed in Table 4.3, the instructions in Table 4.4.)

These instructions that specify a complete 24-bit address to go to, along with native mode’s software interrupt and return from interrupt instructions, are the only ones that modify the value in the program bank register. The program bank can be pushed onto the stack so it can be pulled into another register and be examined or tested. But there is no instruction for pulling the program bank register from the stack, since that would change the bank the next instruction would come from – certain to be catastrophic. To avoid such “strange” branches across banks, the program counter bank register can only be changed when the program counter is changed at the same time.

## The Western Design Center

### The Data Bank Register

The data bank register (**DBR** or, when used as part of a mnemonic, **B**) defines the default bank to be used for reading or writing data whenever one of the addressing modes that specifies (only) a sixteen-bit address is used, such as the absolute, indirect, or indexed instructions found on the 6502. Such sixteen-bit effective addresses as used with the 6502 are concatenated with the value in the data bank register to form a 24-bit address, much as the program counter is concatenated with the program bank register. An important difference is that, unlike the program counter bank register, the data bank register can be *temporarily* incremented by instructions which use indexed addressing; in other words, bank boundaries do not confine indexing, which crosses them into the next bank.

As already mentioned, direct page and stack-based values are always accessed in bank zero, since the implied bank used with the direct page and stack is zero. But *indirect* addresses pulled out of the direct page or off stack (when used with addressing modes that do not further specify the bank value) point to locations in the current data bank.

The existence of the data bank register on the 65816 provides a convenient way to access a large range of data memory without having to resort to 24-bit address operands for every operation.

### The Direct Page Register

The direct page register (**D**) points to the beginning of direct page memory, which replaces zero page memory as the special page used for short-operand addressing. All of the 6502 instructions that use zero page addressing use an expanded form called direct page addressing on the 65816 and 65802. If the direct page register is set to zero, the direct page memory is the zero page, and direct page addressing is operationally identical to zero page addressing.

One effect of having a direct page register is that you can set up and alternate between multiple direct page areas, giving each subroutine or task its own private direct page of memory, which can prove both useful and efficient.

### The Stack Pointer

The native mode stack pointer holds a sixteen-bit address value. This means it can be set to point to any location in bank zero. It also means the stack is no longer limited in length to just \$100 bytes, nor limited to page one (\$100 to \$1FF). Page one therefore loses its character as a “special” memory area and may be treated like any other page while running the 65802 or 65816 in the native mode.

### Accumulator and Index Registers

The key difference between the 65816/65802 and the earlier processors in the series is that the 65816’s three primary user registers – the accumulator and the **X** and **Y** index registers – can be toggled between eight and sixteen bits. You can select which size (eight or sixteen bits) you wish to use by executing special control instructions that modify the new **m** and **x** flags.

This enhances the basic processing power of the chip tremendously. A simple subtraction of sixteen-bit numbers, for example, illustrates the difference. The eight-bit 6502 must be programmed to load the low byte of the first sixteen-bit number, subtract the low byte of the second number, then save the result, load the first number’s high byte, subtract the second number’s, and finally, save the high result. The sixteen-bit processors, on the other hand, can load one sixteen-bit value, subtract the other then save the sixteen-bit result. Three steps replace six.

With its ability to change register size, the 65816 functions equally well with eight bits or sixteen. From the programmer’s point of view, it is a dual word size machine. The machine word size – the basic unit of data the machine processes in a given instruction cycle – may be either **byte** or **double byte**, that is eight or sixteen.

In the terminology used in describing other sixteen-bit processors, the term *word* is used specifically to refer to sixteen-bit data, and *byte* to refer to eight-bit data. But other sixteen-bit processors generally have



## The Western Design Center

different mechanisms for selecting byte or double byte data to operate upon. The terminology appropriate to the 65802 and 65816 is to refer to sixteen-bit data as **double byte**, rather than word, since their word size alternates

between eight bits and sixteen, and since they can operate in either byte mode or double byte mode with equal effectiveness. They are hybrid processors.

The width of the accumulator and the width of the index registers are independently controlled by setting and resetting the two special flag bits within the status register, the **index register select (x)** and **memory/accumulator select (m)** flags. When both are set, the eight-bit register architecture of the 6502 is in force. While very similar to the emulation mode, this eight-bit native mode is subtly different in important ways: a **BRK** vector is available in the native mode; interrupt processing is different between emulation and native mode in general; and of course sixteen-bit processing can be called up with a single instruction. Yet the 65802 and 65816 will execute a good deal of existing 6502 programs without modification in this mode.

When either or both the index register select or memory select flags are cleared, the word size of the corresponding register(s) is expanded from eight bits to sixteen.

The four possible modes of operation are shown in Table 4.1.

eight-bit accumulator	(m bit is set)
eight-bit index registers	(x bit is set)
eight-bit accumulator	(m bit is set)
sixteen-bit index registers	(x bit is clear)
sixteen-bit accumulator	(m bit is clear)
eight-bit index registers	(x bit is set)
sixteen-bit accumulator	(m bit is clear)
sixteen-bit index registers	(x bit is clear)

**Table 4-1 The Four Possible Native Mode Register Combinations**

When the opcode for a given instruction is fetched from memory during program execution, the processor may respond differently based upon the setting of the register select flags. Their settings may be thought of as extensions to the opcode. For example, consider the following instruction:

object	
code	instruction
BD00B0	LDA \$B000 X

which loads the accumulator with data from the effective address formed by the sum of \$B000 and the contents of the X register. The X register contents can be either eight bits or sixteen, depending upon the value of the index select flag. Furthermore, the accumulator will be loaded from the effective address with either eight or sixteen bits of data, depending upon the value of the memory/accumulator select flag.

The instruction and addressing mode used in the example are found also on the 6502 and 65C02; the opcode byte (\$BD) is identical on all four processors. The 65816's new mode flags greatly expand the scope of the 6502's instructions. For programmers already familiar with the 6502, the understanding of this basic principle – how one opcode can have up to four different effects based on the flag settings – is the single most important principle to grasp in moving to a quick mastery of the 65802 or 65816.

## Switching Registers Between Eight and Sixteen Bits

The two register select flags are set or cleared by two new instructions provided for modifying the status register: one of the instructions, **SEP**, (set **P**) can be used to set any bit or bits in the P status register; the other, **REP**, (reset **P**) can be used to reset any bit or bits in the status register.

Figure 4.2 shows the results of changing the index registers and accumulator between eight and sixteen bits. When a sixteen-bit index register is switched to eight bits, the high byte is lost irretrievably and replaced by a zero. On the other hand, when an eight-bit index register is switched to sixteen bits, its unsigned value is retained by concatenating fit to a zero high byte; that is, the eight-bit unsigned index already in the register is extended to sixteen bits.

Unlike the index operations, switching the accumulator's size either direction is reversible. The accumulator is treated differently due to its function, not as an index register, but as the register of arithmetic and logic. In this role, it is often called upon to operate on eight-bit values with sixteen-bit ones and vice versa.

When the sixteen-bit **A** accumulator is switched to eight bits, the low byte becomes the new eight-bit **A** accumulator while the high bit becomes the eight-bit "hidden" **B** accumulator. **B** may be seen as an annex to the **A** accumulator, accessible only through a new instruction which exchanges the values in the two accumulators (making **B** useful for temporarily storing of the eight-bit value in **A**). Conversely, when the accumulator is switched from eight bits to sixteen, the new sixteen-bit **A** accumulator has, as its low byte, the previous eight-bit **A** accumulator and, as its high byte, the previous hidden **B** accumulator.

Certain instructions that transfer the accumulator to or from other sixteen-bit registers refer to the sixteen-bit accumulator as **C** to emphasize that all sixteen accumulator bits will be referenced regardless of whether the accumulator is set to eight- or sixteen-bit mode. Again, this is illustrated in Figure 4.2.

## The Status Register

Because the emulation bit is a "phantom" bit, it cannot be directly tested, set, or cleared. The flag that it "phantoms" or overlays is the carry bit; there is a special instruction, **XCE**, that exchanges the contents of the two flags. This is the "trapdoor" through which the emulation mode is entered and exited.

**Results of Switching Register Sizes**  
**(L = bits in low byte; H = bits in high byte)**  
**Index Registers: 16 Bits to 8**

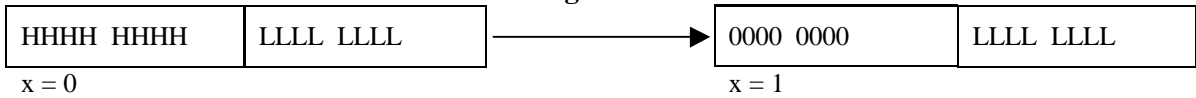

**Index Register: 8 Bits to 16**

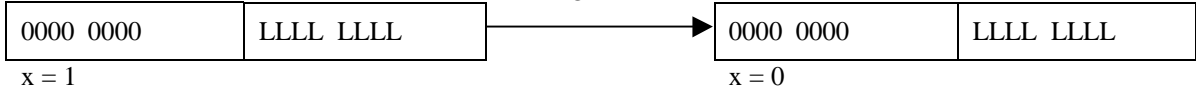

**Accumulator: 16 Bits to 8**

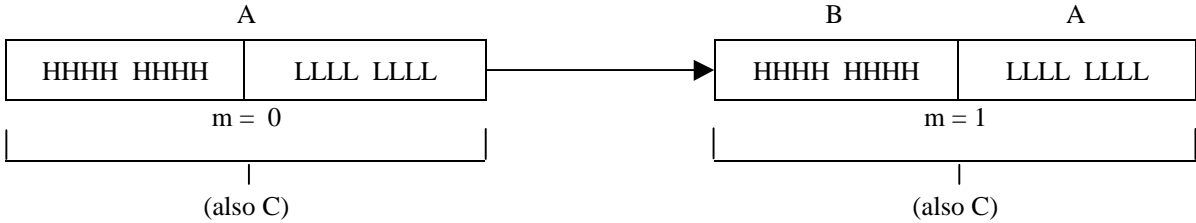

**Accumulator: 8 Bits to 16**

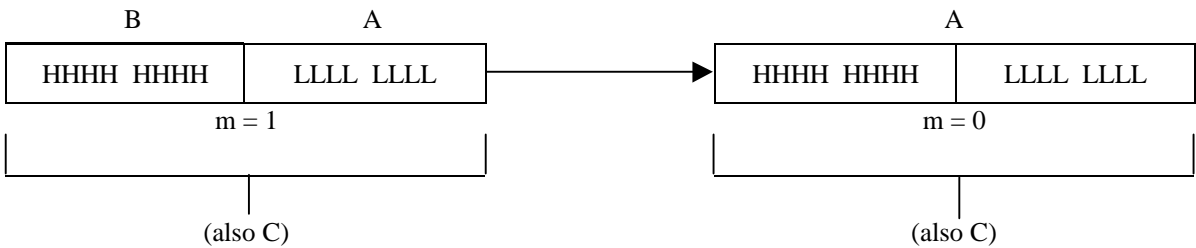

**Figure 4-2 Results of Switching Register Size**

Two status register bits were required for the two-flag eight-or-sixteen-bit scheme. While the 6502's status register has only one unused status register bit available, its break flag is used only for interrupt processing, not during regular program execution, to flag whether an interrupt comes from a break instruction or from a hardware interrupt. By giving the break instruction its own interrupt vector in native mode, the 65816's designers made a second bit available for the **m** and **x** register select flags.

**6502/65C02 Addressing Modes on the 65816**

All of the 6502 and 65C02 addressing modes are available to the 65816/65802, but native mode's sixteen-bit features mean you need to expand your thinking about what they will do. For example, the 65816's direct page, which can be located anywhere in memory, replaces the earlier zero page as the special page for short-operand addressing modes. All 6502/65C02 zero page addressing modes become direct page addressing modes, as shown in Table 4.2.

## The Western Design Center

<i>6502/65C02</i>	<i>65802/65816</i>	<i>Syntax Example Common to Both</i>	
<i>Zero Page Addressing Mode</i>	<i>Direct Page Addressing Mode</i>	<i>Opcode</i>	<i>Operand</i>
Zero Page	Direct Page	LDA	\$55
Zero Page Indexed with X	Direct Page Indexed with X	LDA	\$55, X
Zero Page Indexed with Y	Direct Page Indexed with Y	LDX	\$55, Y
Zero Page Indirect Indexed with Y (Postindexed)	Direct Page Indirect Indexed with Y	LDA	(\$55), Y
Zero Page Indirect Indexed with X (Preindexed)	Direct Page Indexed Indirect with X	LDA	(\$55, X)
Zero Page Indirect	Direct Page Indirect	LDA	(\$55)

**Table 4-2 Addressing Modes: Zero Page vs. Direct Page**

Notice in Table 4.2 that the assembler syntax for each direct page addressing mode (not to mention the object bytes themselves) is the same as its zero page counterpart. The names and the results of the addressing modes are what differ. Direct page addressing, like the 6502/65C02 zero page addressing, allows a memory location to be addressed using only an eight-bit operand. In case of the 6502, a sixteen-bit zero page effective address is formed from an eight-bit offset by concatenating a zero high byte to it. In the 65802/65816, the direct page effective address is formed by adding the eight-bit offset to the sixteen-bit value in the direct register. This lets you relocate the direct page anywhere in bank zero, on any byte boundary. Note, however, that it is most efficient to start the direct page on a page boundary because this saves one cycle for every direct page addressing operation.

When considering the use of 6502/65C02 zero page instructions as 65802/65816 direct page instructions, remember that a direct page address of \$23 is located in memory at location \$0023 only if the direct page register is set to zero; if the direct page register holds \$4600, for example, the direct page address \$23 is located at \$4623. The direct page is essentially an array which, when it was the zero page, began at address zero, but which on the 65816 and 65802 can be set to begin at any location.

In the 6502/65C02, the effective address formed using zero page indexed addressing from a zero page base address of \$F0 and an index of \$20 is \$10; that is, zero page indexed effective addresses wrap around to always remain in the zero page. In the emulation mode this is also true. But in native mode, there is no page wraparound: a direct page starting at \$2000 combined with a direct page base of \$20 and a sixteen-bit index holding \$300 results in an effective address of \$2320.

The three main registers of the 65802/65816 can, in native mode, be set to hold sixteen bits. When a register is set to sixteen bits, then the data to be accessed by that register will also be sixteen bits.

For example, shifting the accumulator left one bit, an instruction which uses the accumulator addressing mode, shifts sixteen bits left rather than eight if the accumulator is in sixteen-bit mode. Loading a sixteen-bit index register with a constant using immediate addressing means that a sixteen-bit value follows the instruction opcode. Loading a sixteen-bit accumulator by using absolute addressing means that the sixteen-bit value stored starting at the absolute address, and continuing into location at the next address, is loaded into the accumulator.

Sixteen-bit index registers give new power to the indexed addressing modes. Sixteen-bit index registers can hold values ranging up to 64K; no longer must the double-byte base of an array be specified as a constant with the index register used for the index. A sixteen-bit index can hold the array base with the double-byte constant specifying the (fixed) index.

Finally, the 65816 has expanded the scope of 6502 and 65C02 instructions by mixing and matching many of them with more of the 6502/65C02 addressing modes. For example, the jump-to-subroutine instruction can now perform absolute indexed indirect addressing, a mode introduced on the 65C02 solely for jump instruction.

### New 65816 Addressing Modes

Not only do the 65802 and 65816 provide all the 6502 and 65C02 addressing modes, but they also offer nine new addressing modes of their own, in both emulation and native modes. They are shown in Table 4.3.

<i>Addressing Mode</i>	<i>Syntax</i>	
	<i>Opcode</i>	<i>Example Operand</i>
Program Counter Relative Long	BRL	JMPLABEL
Stack Relative	LDA	3, S
Stack Relative Indirect Indexed with Y	LDA	(5,S), Y
Block Move	MVP	0,0
Absolute Long	LDA	\$02F000
Absolute Long Indexed with X	LDA	\$12D080, X
Absolute Indirect Long	JMP	[\$2000]
Direct Page Indirect Long	LDA	[\$55]
Direct Page Indirect Long Indexed with Y	LDA	[\$55], Y

**Table 4-3 The 65816/65802's New Addressing Modes**

There are six new addressing modes that use the word “long”, but with two very different meanings. Five of the “long” modes provide 24-bit addressing for intrabank accesses. **Program counter relative long addressing**, on the other hand, provides an intrabank sixteen-bit form of relative addressing for branching. Like all the other branch instructions, its operand is an offset from the current contents of the program counter, but branch long’s operand is sixteen bits instead of eight, which expands relative branching from plus 127 or minus 128 bytes to plus 32767 or minus 32768. This and other features greatly ease the task of writing position-independent code. The use of the word “long” in the description of this addressing mode means “longer than an eight bit offset”, whereas the word “long” used with the other four addressing modes means “longer than sixteen bits”.

**Stack relative addressing** and **Stack relative indirect indexed with Y addressing** treat the stack like an array and index into it. The stack pointer register holds the base of the array, while a one-byte operand provides the index into it. Since the stack register points to the next available location for data, a zero index is meaningless: data and addresses which have been pushed onto the stack start at index one. For stack relative, this locates the data; for stack relative indirect indexed, this locates an indirect address that points to the base of an array located elsewhere. Both give you the means to pass parameters on the stack in a clean, efficient manner. Stack relative addressing is a particularly useful capability, for example, in generating code for recursive high-level languages such as Pascal or C, which store local variables and parameters on a “stack frame”.

**Block move addressing** is the power behind two new instructions that move a block of bytes – up to 64K of them – from one memory location to another all at once. The parameters of the move are held in the accumulator (the count), the index registers (the source and destination addresses), and a unique double operand (source and destination addresses in the operand specify the source and destination banks for the move operation).

The five remaining “long” addressing modes provide an alternative to the use of bank registers for referencing the 65816’s sixteen-megabyte address space. They let you temporarily override the data bank register value to address memory anywhere within the sixteen-megabytes address space. **Absolute long addressing**, for example, is just like absolute addressing except that, instead of providing a two-byte absolute address to be accessed in the data bank, you provide a three-byte absolute address which overrides the databank. **Absolute long indexed with X**, too, is four bytes instead of three. On the other hand, it is the memory locations specified by **absolute indirect long**, **direct page indirect long**, and **direct page indirect long indexed with Y** that hold three-byte indirect addresses instead of two-byte ones. Three-byte addresses in memory appear in conventional 65x order; that is, the low byte is in the lower memory locations, the middle byte (still referred to in 6502 fashion as the “high” byte) is in the next higher location, and the highest (bank) byte is in the highest location.

**Instructions**

There are 78 new opcodes put into use through the 28 new operations listed in Table 4.4, as well as through giving the previous processors' operations additional addressing modes.

<i>Instruction Mnemonic</i>	Description
BRL	Branch always long
COP	Co-processor empowerment
JML	Jump long (interbank)
JSL	Jump to subroutine long(interbank)
MVN	Block move negative
MVP	Block move positive
PEA	Push effective absolute address onto stack
PEI	Push effective indirect address onto stack
PER	Push effective program counter relative address onto stack
PHB	Push data bank register onto stack
PHD	Push direct page register onto stack
PHK	Push program bank register onto stack
PLB	Pull data bank register from stack
PLD	Pull direct page register from stack
REP	Reset status bits
RTL	Return from subroutine long
SEP	Set status bits
STP	Stop the processor
TCD	Transfer 16-bit accumulator to direct page register
TCS	Transfer accumulator to stack pointer
TDC	Transfer direct page register to 16-bit accumulator
TSC	Transfer stack pointer to 16-bit accumulator
TXY	Transfer index registers X to Y
TYX	Transfer index registers Y to X
WAI	Wait for interrupt
WDM	Reserved for future two-byte opcodes
XBA	Exchange the B and A accumulators
XCE	Exchange carry and emulation bits

**Table 4-4 New 65816/65802 Instructions**

Five of the new push and pull instructions allow the new registers to be stored on the stack; the other three let you push constants and memory values onto the stack without having to first load them into a register. **PER** is unique in that it lets data be accessed relative to the program counter, a function useful when writing relocatable code.

There are also instructions to transfer data between new combinations of the registers; including between the index registers – a long-wished-for operation; to exchange the two bytes of the sixteen-bit accumulator; and to exchange the carry and emulation bits, the only method for toggling the processor between emulation and native modes.

There are new jump, branch, return, and move instructions already described in the section on addressing modes. There's a new software interrupt provided for sharing a system with a co-processor. There are two instructions for putting the processor to "sleep" in special low-power states. And finally, there's a reserved opcode, called **WDM** (the initials of the 65816's designer, William D. Mensch, Jr.), reserved for some future compatible processor as the first byte of a possible 256 *two-byte* opcodes.

## Interrupts

Native mode supplies an entire set of interrupt vectors at different locations from the emulation mode (and earlier 6502/65C02) ones to service native mode and emulation mode interrupts differently. Shown in Table 4.5, all are in bank zero; in addition, the sixteen-bit contents of each vector points to a handling routine which must be located in bank zero.

	Emulation Mode	Native Mode
IRQ	FFFE,FFFF	FFEE,FFEF
RESET	FFFC,FFFD	-
NMI	FFFA,FFFB	FFEA,FFEB
ABORT	FFF8,FFF9	FFE8,FFE9
BRK	-	FFE6,FFE7
COP	FFF4,FFF5	FFE4,FFE5

All locations are in bank zero.

**Table 4-5 Interrupt Vector Locations**

As discussed earlier in this chapter, native mode frees up the **b** bit in the status register by giving the break instruction its own vector. When the **BRK** is executed, the program counter and the status register are pushed onto the stack and the program counter is loaded with the address at \$FFE6, the break instruction vector location.

The reset vector is only available in emulation mode because reset always returns the processor to that mode.

The 65816/65802, both emulation and native modes, also provides a new co processor interrupt instruction to support hardware co processing, such as by a floating point processor. When the **COP** instruction is encountered, the 65802's interrupt processing routines transfer control to the co-processor vector location.

Finally, the pinout on the 65816 provides a new **abort** signal. This lets external hardware prevent the 65816 from updating memory or registers while completing the current instruction, useful in sophisticated memory-management schemes. An interrupt-like operation then occurs, transferring control through the special abort vector.

## The 65802 Native Mode

For all that the 65816 is, it is not pin-compatible with the 6502 and 65C02. You can't just replace the earlier chips with it. It is here that the other version of this chip, the 65802, comes to its glory. The price, of course, is that the 65802 has the same addressability limitations as the 6502 and 65C02.

Figure 4.3 shows the programming model for the 65802's native mode. The bank registers, while they exist, do not modify addressability, so they are shown as eight-bit entities. All registers have been scaled back to sixteen bits. There is only one bank a 65802 can address; since it holds the direct page, the stacker point, and the interrupt vectors (bank-zero features on the 65816), you can consider the 65802's bank to be bank zero. Otherwise, the programming model is identical to the 65816's.

The bank registers are an anomaly. They have no function because the packaging provides no pins to connect them to. But they exist because, inside the package, the chip itself is a 65816. In fact, you can change their value just as you would on the 65816, with a pull instruction, a long jump or **JSR**, an interrupt, or a long return, either from subroutine or from interrupt. Furthermore, *every* interrupt and return from interrupt pushes the program bank byte onto the stack or pulls it off, just like the 65816 does. But the bank register values are ignored (stripped from 24-bit addresses when they're sent to the sixteen-bit output pins).

The long addressing modes also seem misplaced here. You can execute instructions using long addressing on the 65802, but the bank addresses are, again, ignored. They are certainly an inefficient method for undertaking intrabank accesses and transfers, since they take up extra bytes for the bank address, and use up extra cycles in translation. Still, they cause the 65802 no problems, as long as you understand that the bank value is disregarded and only the remaining sixteen bits of address are effective in pointing to an address in the 65802's single addressable bank of memory.

## The Western Design Center

Five of the new push and pull instructions allow the new registers to be stored on the stack; the other three let you push constants and memory values onto the stack without having to first load them into a register. **PER** is unique in that it lets data be accessed relative to the program counter, a function useful when writing relocatable code.



**65802 Native Mode Programming Model**

(16-bit accumulator & index register modes: m=0 & x=0)

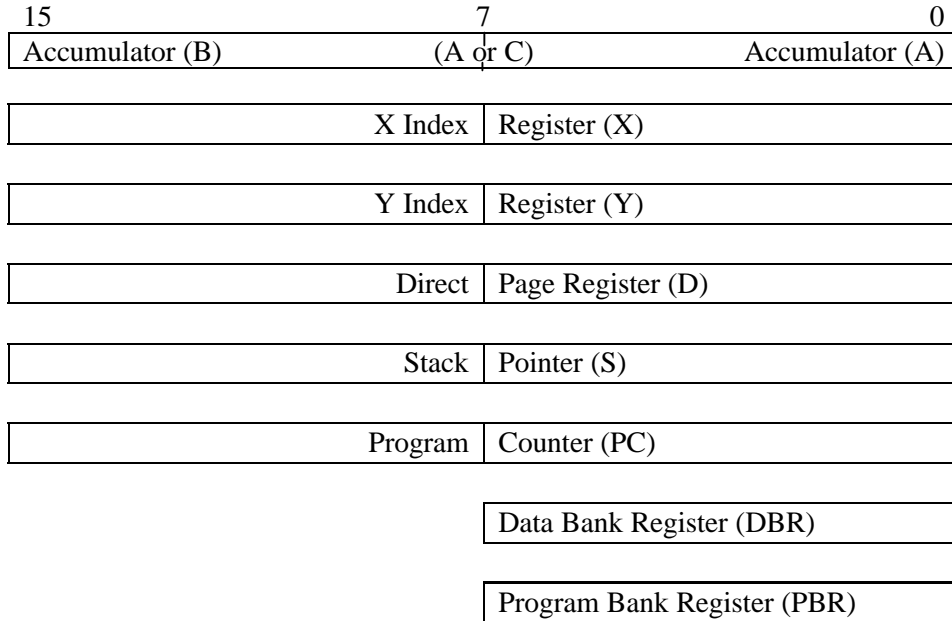

Processor Status Register (P)

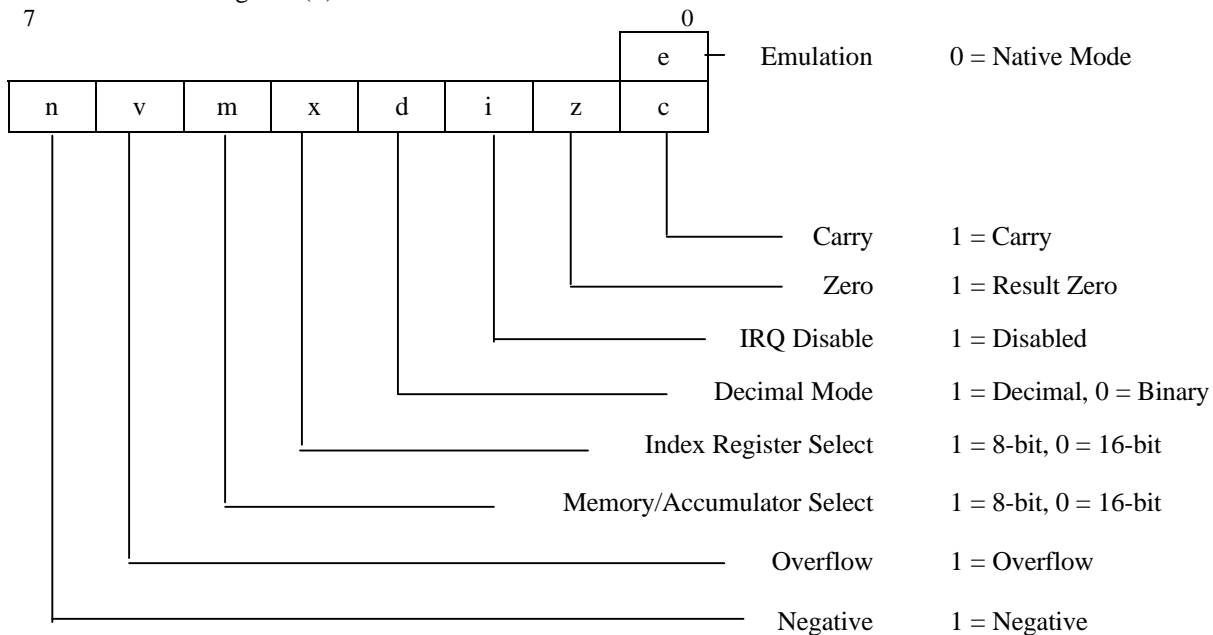

**Figure 4-3 65802 Native Mode Programming Model**

Finally, the bank bytes specified to the block move instructions are ignored, too. Block moves are by necessity entirely intrabank on the 65802.

Because the abort signal was designed into the 65816 by virtue of its redesigned pinout, its vector exists on the 65802 but has no connection to the outside world. Since there is no way to abort an instruction without using the external pin, the abort operation can never occur on the 65802.

In all other respects, the 65802 and the 65816 are identical, so the 65802 can almost be thought of as a 65816 in a system with only 64K of physical memory installed. Table 4.6 summarizes the differences between the 65802 and 65816 native modes and the 6502 and 65C02.

## The Western Design Center

### Emulation Mode

That the 65802 provides a pinout the same as the 6502's and the 65C02's is not enough to run all the software written for the earlier two processors. For one thing, the eight-bit software expects interrupt handlers to distinguish break instructions by checking the stacked break flag, and the 65802's native mode has no break flag, having replaced both it and the 6502's unused flag with the **m** and **x** flags. For another, 6502 instructions that use eight-bit registers to set the stack would set only half of the sixteen-bit stack. The native mode interrupt vectors are only half of the sixteen-bit stack. The native mode interrupt vectors are different from their 6502/65C02 counterparts, as Table 4.5 showed. There are also little differences; for example, while the direct page can be set to the zero page, direct page indexed addresses can cross pages in native mode, but wrap on the 6502 and 65C02.

Reaching beyond hardware compatibility to software compatibility was clearly so important that the designers of the 65802 and 65816 devised the 6502 **emulation mode** scheme. Both processors power-on in emulation mode, with the bank registers and the direct page register initialized to zero. As a result of both this and having the same pinout, a 65802 can be substituted for a 6502 in any application and will execute the existing software the same. Furthermore, it is possible to design second-generation 65816 systems compatible with existing 6502 designs which, provided the computer's designers do as good a job in providing compatibility as the 65816's designers have, could run all existing software of the first generation system in emulation mode, yet switch into native mode for sixteen-bit power and 24-bit addressing.

It is important to realize, however, that 6502 emulation mode goes far beyond emulating the 6502. It embodies all the addressing mode and instruction enhancements of both the 65C02 and the 65802/65816; it has a fully relocatable direct page register; it provides the stack relative addressing modes; and in the 65816's emulation mode, it can switch between banks to use 24-bit addressing. The primary differences between native and emulation modes are limitations placed on certain emulation mode registers and flags so that existing programs are not surprised (and crashed) by non-6502-like results. These differences are summarized in Table 4.6.

Table 4-6 Major Differences Between Processors and Modes

	6502	65C02	65802 Native	65802 Emulation	65816 Native	65816 Emulation
6502 pinout	yes	yes	yes	yes	no	no
6502 timing	yes	no	no	yes	no	yes
abort signal	no	no	no	no	yes	yes
accumulator	8 bits	8 bits	16 or 8/8 bits	8/8 bits	16 or 8/8 bits	8/8 bits
addressing modes	14	16	25	25	25	25
address space	64K	64K	64K	64K	16M	16M
bank registers	none	none	not connected	not connected	yes	yes
block moves	none	none	yes	of little use	yes	of little use
break flag	yes	yes	no	yes	no	yes
decimal mode flag	N, V, Z invalid	N, V, Z invalid	N, V, Z valid	N, V, Z valid	N, V, Z valid	N, V, Z valid
direct page indexed	wraps	wraps	crosses page	wraps	crosses page	wraps
flags after interrupt	D not modified	D = 0	D = 0	D not modified	D = 0	D not modified
flags after reset	D unknown	D = 0	D = 0	D not modified	D = 0	D not modified
index registers	8 bits	8 bits	8 or 16 bits	8 bits	8 or 16 bits	8 bits
instructions	151	178	256	256	256	256
interrupts	FFFA, FFFF	FFFA, FFFF	FEE4, FFEF	FFF4, FFFF	FEE4, FFEF	FFF4, FFFF
mnemonics	56	64	92	92	92	92
special page	zero page	zero page	direct page	direct page	direct page	direct page
stack	page 1	page 1	bank 0	page 1	bank 0	page 1
unused opcodes	could crash	NOP	none	none	none	none

## The Western Design Center

The pair of 65816 instructions have little use in emulation mode are the block move instructions. Because the source and destination parameters for moves are passed to the instruction in the index registers, their eight-bit limits confine the instruction to the zero page: a block can only be moved from one zero page location to another.

Only in emulation mode do 65802/65816 interrupt vectors match their 6502/65C02 counterparts. Native mode interrupt vectors have their own locations, as Table 4.5 showed.

## Emulation Mode Registers

The 65802/65816, under emulation mode, has the same six registers as the 6502/65C02. In addition, all of the new 65802/65816 registers are available in some form, although some of these on a limited basis. Figure 4.4 shows the result.

The primary accumulator **A** is always limited to eight bits by lack of an **m** flag, but hidden eight-bit accumulator **B** is available, as with the native mode eight-bit accumulator setting. For certain register-transfer operations, the two are combined to form the sixteen-bit register **C**, just as in native mode. The index registers are limited to eight bits by lack of a **x** flag. The direct page register is fully functional, although direct page indexing wraps rather than crossing into the next page. The stack pointer is curtailed to page one, as on the 6502 and 65C02; if a sixteen-bit value is used to set it, the high bit is ignored. Finally there are two bank registers, which are initialized to zero, but which can be changed to point to other banks.

Now look at the **P** status register. In addition to the eight bits of the standard 6502/65C02 status register, you'll see the ninth "phantom" **e** bit, which contains a one; this setting puts the processor into its 6502 emulation mode.

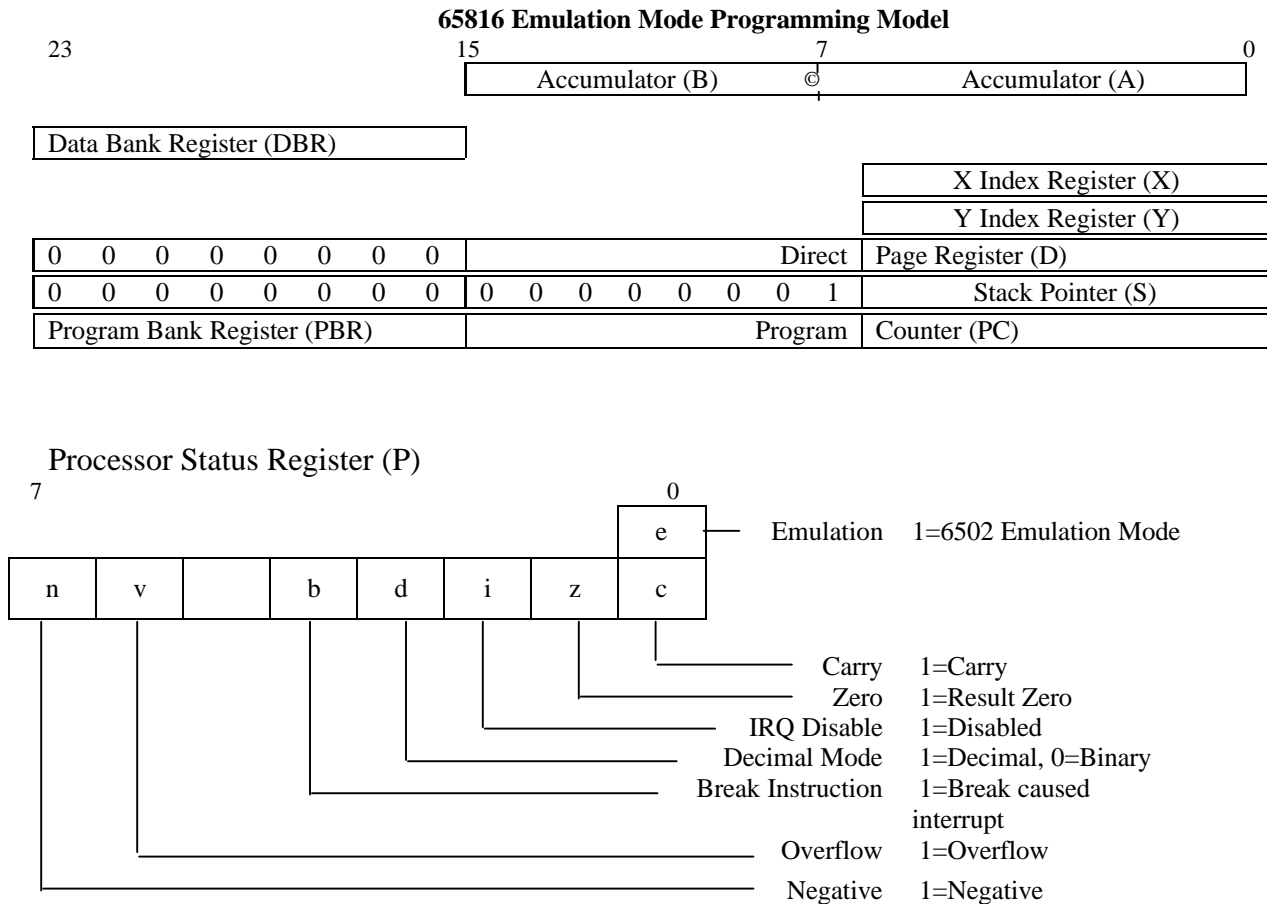

Figure 4-4 65816 Emulation Mode Programming Model

## The Western Design Center

The **A** and **B** registers, which together make up the native mode sixteen-bit accumulator, are used together in emulation mode as **C** solely for transferring values to and from the direct page register and the stack.

The direct page register (**D**) points to the beginning of direct page memory. You'll probably normally set it to zero in the emulation mode to make the direct page identical to 6502 zero page memory. This is particularly true if your 65802 program is running within a 6502 or 65C02 operating system. The operating system will have stored values to zero page memory; if you change the direct page to point to another page, then call an operation system routine, the operating system will load its information from the wrong direct page (any page other than the zero page) and fail miserably.

## Switching Between 6502 Emulation and Native Modes

As you've seen, the native mode and the 6502 emulation mode embody a number of significant differences. When running the 65802 in an older machine, such as Apple II c, II e, or II Plus, you will probably call your 65802 programs from a 6502 operating system or program. Your 65802 code can immediately switch the processor into native mode, so you can take advantage of the additional power. You must, however, switch back to emulation mode to use any I/O routines, or to call the 6502-based operating system.

Understanding the transitions between the two modes is critical, particularly in an environment where you are switching back and forth between 6502 systems programs and your own 65802 code.

### Switching from Emulation to Native Mode

When the 65802 is switched from emulation to native mode, the value in the status register's carry bit winds up being toggled. Native mode is set by sweeping a cleared carry bit with the current value in the emulation bit (which was a one if the processor was in emulation mode). The **m** and **x** flags in the status register are switched into place (replacing the **b** break flag) and the processor automatically forces the flags to one which leaves the accumulator and index registers as eight-bit registers, the same as they were in emulation mode. The rest of the bits in the status register remain the same.

While the emulation mode stack pointer register is only eight-bit register, it can be thought of as a sixteen-bit register with its high byte hard-wired to one, so that the emulation stack is always in page one. When the 65802 is switched from emulation to native mode, the sixteen-bit native mode stack pointer assumes the same value the emulation mode stack pointer has been pointing to - page one address.

All other registers make the transition unchanged.

### Switching from Native to Emulation Mode

Switching from native to emulation mode also toggles the carry. The carry bit is set, then exchanged with the emulation bit to force the processor back into emulation mode. Provided the processor was previously in native mode, the carry flag is cleared. The status register's **m** and **x** bits disappear, forcing the accumulator and index registers back to eight bits. If the index registers were in sixteen-bit mode, they keep their low bytes, but their high bytes are permanently lost. If, on the other hand, the accumulator was in sixteen-bit mode, the low byte remains in accumulator **A** while the high byte remains accessible as the hidden accumulator **B**. The **m** bit (bit five) returns to its emulation role as the break flag; the **x** bit (bit four) becomes once again an unused flag.

The stack is truncated from sixteen to eight bits, with its high byte forced to a one; that is, the stack is forced to page one. Any value in the high byte of the stack pointer register is permanently lost, which means you must be very careful not to "lose" a non-page-one stack. Solving this and other sticky problems involved with calling an emulation mode routine from native mode is the goal of one of the routines in Chapter 14.

All other registers make the transition unchanged.

## **65802/65816 Bugs and Quirks**

As on the 65C02, the 6502's bugs are corrected by the 65802. Unlike the 65C02, however, the 65802 fixes the bug either only in native mode or without modifying the 6502's cycle counts (as the 65C02 in some cases does). There are no unused opcodes on the 65802, although there is an opcode which, while technically "used", is really reserved. If executed, it acts like a no-operation instruction.

The most anomolous feature of the 65816 is the behavior of new opcodes while in the 6502 emulation mode. While strict 6502 compatibility is enforced for all 6502 and 65C02 opcodes, this is not the case with new opcodes. For example, although the high byte of the stack registers is always set to one, wrapping of the stack during the execution of a single non-6502 instruction is not supported. These issues are discussed more fully in Chapter 16.

Because the 65802 fixes the 6502's bugs and quirks while leaving that chip's timing cycles untouched, the 65802 is in fact a hair more compatible as an upgrade chip than it the 65C02.

**Part 3**  
**Tutorial**

## 5) Chapter Five

### SEP, REP, and Other Details

Part Three is devoted to a step by step survey of all 92 different 65816 instructions and the 25 different types of addressing modes which, together, account for the 256 operation codes of the 65802 and 65816. As a matter of course, this survey naturally embraces the instruction sets of the 6502 and 65C02 as well.

The instructions are grouped into six categories: data movement, flow of control, arithmetic, logical and bit manipulation, subroutine calls, and system control instructions. A separate chapter is devoted to each group, and all of the instructions in a group are presented in their respective chapter.

The addressing modes are divided into two classes, simple and complex. The simple addressing modes are those that form their effective address directly - that is, without requiring any, or only minimal, combination or addition of partial addresses from several sources. The complex addressing modes are those that combine two or more of the basic addressing concepts, such as indirection and indexing, as part of the effective address calculation.

Almost all of the examples found in this book are intended to be executed on a system with either a 65802 or 65816 processor, and most include 65816 instructions, although there are some examples that are intentionally restricted to either the 6502 or 65C02 instructions set for purpose of comparison.

Because of the easy availability of the pin-compatible 65802, there is a good chance that you may, in fact, be executing your first sample programs on a system originally designed as a 6502-based system, with system software such as machine-level monitors and operating systems that naturally support 6502 code only. All of the software in this book was developed and tested on just such systems (AppleII computers with either 65802s replacing the 6502, or with 65816 processor cards installed).

It is assumed that you will have some kind of support environment allowing you to develop programs and load them into memory, as well as a monitor program that lets you examine and modify memory, such as that found in the Apple II firmware. Since such programs were originally designed to support 6502 code, the case of calling a 65816 program from a 6502-based system program must be given special attention.

A 65802 or 65816 system is in the 6502 emulation mode when first initialized at power-up. This is quite appropriate if the system software you are using to load and execute the sample programs is 6502-based, as it would probably not execute correctly in the native 65816 mode.

Even though almost all of the examples are for the 65816 native mode of operation, the early examples assume that the direct page register, program counter bank register, and data register are all in their default condition - set to zero - in which case they provide an environment that corresponds to the 64K programming space and zero page addressing of the 6502 and 65C02. Aside from keeping the examples simple, it permits easy switching between the native mode and the emulation mode. If you have just powered up your 65816 or 65802 system, nothing needs be done to alter these default values.

The one initialization you must do is switch from the emulation to the native mode. To switch out of the 6502 emulation mode, which is the default condition upon powering up a system, the code in Fragment 5.1 must be executed once.

0000	18	CLC	clear carry flag
0001	FB	XCE	exchange carry with e bit (clears e bit)

**Fragment 5.1.**

This clears the special **e** flag, putting the processor into the 65816 native mode.

If you are using a 65802 processor in an old 6502 system, the above code needs to be executed each time an example is called. Further, before exiting a 65816 program to return to a 6502 calling program, the opposite sequence in Fragment 5.2 must be executed.



## The Western Design Center

0000	38	SEC	set carry flag
0001	FB	XCE	exchange carry with e bit (set e bit)

### Fragment 5.2.

Even if you are running your test programs from a fully supported 65816 or 65802 environment, you should include the first mode-switching fragment, since the operating mode may be undefined on entry to a program. Execution of the second should be acceptable since the system program should reinitialize itself to the native mode upon return from a called program.

A further requirement to successfully execute the example programs is to provide a means for returning control to the calling monitor program. In the examples, the **RTS** (return from subroutine) instruction is used. The **RTS** instruction is not explained in detail until Chapter 12; however, by coding it at the end of each example, control will normally return to the system program that called the example program. So to exit a program, you will always code the sequence in Fragment 5.3.

0000	38	SEC	set carry flag
0001	FB	XCE	exchange carry with e bit (sets e bit)
0002	60	RTS	

### Fragment 5.3.

Some systems may have a mechanism other than **RTS** to return control to the system; consult your system documentation.

In addition to these two details, a final pair of housekeeping instructions must be mastered early in order to understand the examples.

These two instructions are **SEP** and **REP** (set **P** and reset **P**). Although they are not formally introduced until Chapter 13, their use is essential to effective use of the 65802 and 65816. The **SEP** and **REP** instructions have many uses, but their primary use is to change the value of the **m** and **x** flags in the status register. As you recall from Chapter 4, the **m** and **x** registers determine the size of the accumulator and index registers, respectively. When a flag is set (has a value of one), the corresponding register is eight bits; when a flag is clear, the corresponding register is sixteen bits. **SEP**, which *sets* bits in the status register, is used to change either accumulator, or index registers, or both, to eight bits; **REP**, which *clears* bits, is used to change either or both to sixteen bits. Whenever a register changes size, all of the operations that move data in and out of the register are affected as well. In this sense, the flag bits are extensions to the opcode, changing their interpretation by the processor.

The operand following the **SEP** and **REP** instructions is a “mask” of the flags to be modified. Since bit five of the status register is the **m** memory/accumulator select flag, an instruction of the form:

**REP**      %#00100000

makes the accumulator size sixteen bits; a **SEP** instruction with the same argument (or its hexadecimal equivalent, \$20) would make it eight bits. The binary value for modifying the **x** flag is %00010000, or \$10; the value for modifying both flags at once is %00110000, or \$30. The sharp (#) preceding the operand signifies the operand is immediate data, stored in the byte following the opcode in program memory; the percent (%) and dollar (\$) signs are special symbols signifying either binary or hexadecimal number representation, respectively, as explained in Chapter 1.

Understanding the basic operation of **SEP** and **REP** is relatively simple. What takes more skill is to develop a sense of their appropriate use, since there is always more than one way to do things. Although there is an immediate impulse to want to use the sixteen-bit modes for everything, it should be fairly obvious that the eight-bit accumulator mode will, for example, be more appropriate to applications such as character manipulation. Old 6502 programmers should resist the feeling that if they’re not using the sixteen-bit modes “all the time” they’re not getting full advantage from their 65802 or 65816. The eight-bit accumulator and index register size modes, which correspond to the 6502 architecture, can be used to do some of the kinds of

## The Western Design Center

things the 6502 was doing successfully before the *option* of using sixteen-bit registers was provided by the 65816. Even in eight-bit mode, the 65802 or 65816 will provide numerous advantages over the 6502.

What is most important is to develop a sense of rhythm; it is undesirable to be constantly switching modes. Since the exact order in which a short sequence of loosely related instructions is executed is somewhat arbitrary, try to do as many operations in a single mode as possible before switching modes. At the same time, you should be aware that the point at which an efficiency gain is made by switching to a more appropriate mode is reached very quickly. By examining the various possibilities, and experimenting with them, a sense that translates into an effective rhythm in coding can be developed.

Finally, a word about the examples as they appear in this book. Two different styles are used: Code Fragments, and complete Code Listings.

Code Fragments are the kinds of examples used so far in this chapter. Code Listings, on the other hand, are self-contained programs, ready to be executed. Both appear in boxes, and are listed with the generated object code as produced by the assembler. Single-line listings are included in the text.

## The Assembler Used in This Book

The assembly syntax used in this book is that recommended by the Western Design Center in their data sheet (*see* Appendix F). The assembler actually used in the ProDOS ORCA / M assembler for the Apple II computer, by Byteworks, Inc. Before learning how to code the 65816, a few details about some of the assembler directives need to be explained.

Full-line comments are indicated by starting a line with an asterisk or a semicolon.

If no starting address is specified, programs begin by default at \$2000. That address can be changed by using the origin directive, **ORG**. The statement

```
ORG          $7000
```

When included in a source program, will cause the next byte of code generated to be located at memory location \$7000, with subsequently generated bytes following it.

Values can be assigned labels with the global equate directive, **GEQU**. For example, in a card-playing program, spades might be represented by the value \$7F; the program is much easier to code (and read) if you can use label **SPADE** instead of remembering which of four values goes with which of the four suits, as seen in Fragment 5.4.

0000	SPADE	GEQU	\$7F
0000	HEART	GEQU	\$FF
0000	CLUB	GEQU	\$3F
0000	DIAMOND	GEQU	\$1F

**Fragment 5.4.**

Now rather than loading the **A** accumulator by specifying a hard-to-remember value,

```
A97F          LDA          #$7F
```

You can load it by specifying the easier-to-remember label:

```
A900          LDA          #SPADE
```

Once you have defined a label using **GEQU**, the assembler automatically substitutes the value assigned whenever the label is encountered.

The # sharp or pound sign is used to indicate that the accumulator is to be loaded with an immediate constant.

## The Western Design Center

In addition to being defined by **GEQU** statements, labels are also defined by coded in the label field - starting in the first column of a source line, right in front of an instruction or storage-defining directive. When coded in front of an instruction:

```
A905      BEGIN      LDA      #5
```

The label defines an entry point for a branch or jump to go to; when an instruction such as is assembled,

```
4C0400    JMP      BEGIN
```

the assembler automatically calculates the value of **BEGIN** and uses that value as the operand of the **JMP** instruction.

Variable and array space can be set aside and optionally labelled with the define storage directive, **DS** directive sets aside one byte at \$1000 for the variable **FLAG1**; the second **DS** directive sets aside 20 bytes starting at \$1001 for **ARRAY1**.

0000			ORG	\$1000
0000		MAIN	START	
0000	00	FLAG1	DS	1
0001	00000000	ARRAY1	DS	20
0015			END	

### Fragment 5.5

The value stored at **FLAG1** can be loaded into the accumulator by specifying **FLAG1** as the operand of the **LDA** instruction:

```
AD0010    LDA      FLAG1
```

Program constants, primarily default values for initializing variables, prompts, and messages, are located in memory and optionally given a label by the declare constant directive, **DC**. The first character(s) of its operand specifies a type (**A** for two-byte addresses, **I** for one-byte integers, **H** for hex bytes and **C** for character strings, for example) followed by the value or values to be stored, which are delimited by single quotes.

Fragment 5.6 gives an example. The first constant, **DFLAG1**, is a default value for code in the program to assign to the variable **FLAG1**. You may realize that **DFLAG1** could be used as a variable; with a label, later values of the flag could be stored here and then there would be no need for any initialization code. But good programming practice suggests otherwise: once another value is stored into **DFLAG1**, its initial value is lost, which keeps the program from being restarted from memory. On the other hand, using a **GEQU** to set up **DFLAG1** would prevent you from patching the location with a different value should you change your mind about its initial value after the code has been assembled.

0000	FE	DFLAG1	DC	I ' \$FE '
0001	0010	COUNT	DC	A ' \$1000 '
0003	496E7365	PROMPT	DC	C ' Insert disk into drive 1 '
001B	00		DC	I ' 0 '

### Fragment 5.6

Defining **COUNT** as a declared constant allows it, too, to be patched in object as well as edited in source.

**PROMPT** is a message to be written to the screen when the program is running. The assembler lists only the first four object bytes generated ('496E7365') to save room, but generates them all. The zero on the next line acts as a string terminator.

Sometimes it is useful to define a label at a given point in the code, but not associate it with a particular source line; the **ANOP** (assembler no-operation) instruction does this. The value of the label will be the

## The Western Design Center

location of the code resulting from the next code-generating source line. One use of this feature is to define two labels with the same value, as shown in Fragment 5.7.

0000		BLACK	ANOP	
0000	0000	WHITE	DS	2

**Fragment 5.7**

The two bytes of variable storage reserved may now be referred to as either **BLACK** or **WHITE**; their value is the same.

## Address Notation

The 16-megabyte address space of the 65816 is divided into 256 64K banks. Although it is possible to treat the address space in a linear fashion - the range of bytes from \$000000 to \$FFFFFF - it is often desirable and almost always easier to read if you distinguish the bank component of a 24-bit address by separating it with a colon:

```
$00:FFF0  
$xx:1234  
$01:XXXX
```

In these examples, the X characters indicate that that address component can be any legal value; the thing of interest is the specified component.

Similarly, when specifying direct page addresses, remember that a direct page address is only an offset; it must be added to the value in the direct page register:

```
dp:$30  
$1000:30
```

The **dp** in the first example is used to simply indicate the contents of the direct page register, whatever it may be; in the second case, the value in the direct page register is given as \$1000. Note that this notation is distinguished from the previous one by the fact that the address to the left of the colon is a sixteen-bit value, the address on the right is eight. Twenty-four-bit addresses are the other way around.

A third notation used in this book describes ranges of address. Whenever two addresses appear together separated by a single dot, the entire range of memory location between and including the two addresses is being referred to. For example, \$2000.2001 refers to the double-byte starting at \$2000. If high bytes of the second address are omitted, they are assumed to have the same value as the first address. Thus, \$2000.03 refers to the addresses between \$2000 and \$2003 inclusive.

## 6) Chapter Six

### First Examples: Moving Data

Most people associate what a computer does with arithmetic calculations and computations. That is only part of the story. A great deal of compute time in any application is devoted to simply moving data around the system: from here to there in memory, from memory into the processor to perform some operation, and from the processor to memory to store a result or to temporarily save an intermediate value. Data movement is one of the easiest computer operations to grasp and is ideal for learning the various addressing modes (there are more addressing modes available to the data movement operations than to any other class of instructions). It, therefore, presents a natural point of entry for learning to program the 65x instruction set.

On the 65x series of processors - the eight-bit 6502 and 65C02 and their sixteen-bit successors, the 65802 and 65816 - you move data almost entirely using the microprocessor registers.

This chapter discusses how to load the registers with data and store data from the registers to memory (using one of the simple addressing modes as an example), how to transfer and exchange data between registers, how to move information onto and off of the stack, and how to move blocks (or strings) of data from one memory location to another (*see* Table 6-1).

## The Western Design Center

Mnemonic	Available on:			Description
	6502	65C02	65802/816	
<i>Load/Store Instructions:</i>				
LDA	x	x	x	load the accumulator
LDX	x	x	x	load the X index register
LDY	x	x	x	load the Y index register
STA	x	x	x	store the accumulator
STX	x	x	x	store the X index register
STY	x	x	x	store the Y index register
<i>Push Instructions:</i>				
PHA	x	x	x	push the accumulator
PHP	x	x	x	push status register (flags)
PHX		x	x	push X index register
PHY		x	x	push Y index register
PHB			x	push data bank register
PHK			x	push program bank register
PHD			x	push direct page register
<i>Push Instructions Introduced:</i>				
PEA			x	push effective absolute address
PEI			x	push effective indirect address
PER			x	push effective relative address
<i>Pull Instructions:</i>				
PLA	x	x	x	pull the accumulator
PLP	x	x	x	pull status register (flags)
PLX		x	x	pull X index register
PLY		x	x	pull Y index register
PLB			x	pull data bank register
PLD			x	pull direct page register
<i>Transfer Instructions:</i>				
TAX	x	x	x	transfer A to X
TAY	x	x	x	transfer A to Y
TSX	x	x	x	transfer S to X
TXS	x	x	x	transfer X to S
TXA	x	x	x	transfer X to A
TYA	x	x	x	transfer Y to A
TCD			x	transfer C accumulator to D
TDC			x	transfer D to C accumulator
TCS			x	transfer C accumulator to S
				<i>(Continued)</i>
TSC			x	transfer S to C accumulator
TXY			x	transfer X to Y
TYX			x	transfer Y to X
<i>Exchange Instructions:</i>				
XBA			x	exchange B & A accumulator
XCE			x	exchange carry & emulation bits
<i>Store Zero to Memory:</i>				
STZ		x	x	store zero to memory
<i>Block Moves:</i>				
MVN			x	move block in negative direction
MVP			x	move block in positive direction

**Table 6-1 Data Movement Instruction**

## The Western Design Center

When programming the 6502, whether you're storing a constant value to memory or moving data from one memory location to another, one of the registers is always intermediate. The same is generally true for the other 65x processors, with a few exceptions: the 65816's two block move instructions, three of its push instructions, and an instruction first introduced on the 65C02 to store zero to memory.

As a result, two instructions are required for most data movement: one to load a register either with a constant value from program memory or with a variable value from data memory; the second to store the value to a new memory location.

Most data is moved via the accumulator. This is true for several reasons. First, the accumulator can access memory using more addressing modes than any of the other registers. Second, with a few exceptions, it's only in the accumulator that you can arithmetically or logically operate on data (although the index registers, in keeping with their role as loop counters and array pointers, can be incremented, decremented, and compared). Third, data movement often takes place inside of loops, program structures in which the index registers are often dedicated to serving as counters and pointers.

### Loading and Storing Registers

To provide examples of the six basic data-movement instructions - **LDA**, **LDX**, **LDY** (load accumulator or index registers) and **STA**, **STX**, and **STY** (store accumulator or index registers) - requires introducing at least one of the 65x addressing modes. Except for certain instructions - such as push and pull, which use forms of stack addressing - the **absolute** addressing mode will generally be used in this chapter. Absolute addressing, available on all four 65x processors, is one of the simplest modes to understand. It accesses data at a known, fixed memory location.

For example, to move a byte from one absolute memory location to another, load a register from the first location, then store that register to the other location. In Listing 6.1, the eight-bit value \$77 stored at the absolute location identified by the label **SOURCE** is first loaded into the accumulator, then saved to the absolute location **DEST**. Note the inclusion of the mode-switching code described in the previous chapter.

The code generated by the assembler, when linked, will begin at the default origin location, \$2000. The example generates 13 (\$0D) bytes of actual code (the address of the **RTS** instruction is at memory location \$200C). The assembler then automatically assigns the next available memory location, \$200D, to the label on the following line, **SOURCE**. This line contains a **DC (define constant)** assembler directive, which causes the hexadecimal value \$77 to be stored at that location in the code file (\$200D). Since only one byte of storage is used, the data storage location reserved for the label **DEST** on the next line is \$200E.

The syntax for absolute addressing lets you code, as an instruction's operand, either a symbolic label or an actual value. The assembler converts a symbolic operand to its correct absolute value, determined from its context that absolute addressing is intended, and generates the correct opcode for the instruction using absolute addressing. The assembler-generated hexadecimal object code listed to the left of the source code shows that the assembler filled in addresses \$000D and \$000E as the operands for the **LDA** and **STA** instructions, respectively (they are, of course, in the 65x's standard low-high order and relative to the \$0000 start address the assembler assigns to its relocatable modules; the linker will modify these addresses to \$200D and \$200E when creating the final loadable object).

As Chapter 4 explained, the 65816's accumulator can be toggled to deal with either eight-bit or sixteen-bit quantities, as can its index registers, by setting or resetting the **m** (memory/accumulator select) or **x** (index register select) flag bits of the status register. You don't need to execute a **SEP** or **REP** instruction before every instruction or every memory move, *provided* you know the register you intend to use is already set correctly. But always be careful to avoid making invalid assumptions about the modes currently in force, particularly when transferring control from code in one location to code in another.

The load and store instructions in Listing 6.1 will as easily move a double byte as they did a byte, if the register you use is in sixteen-bit mode, as in Listing 6.2.

## The Western Design Center

0001	0000			KEEP	KL.6.1	
0002	0000			65816	ON	
0003	0000					
0004	0000		MAIN	START		
0005	0000					
0006	0000			;	code to switch from 6502 emulation to native mode	
0007	0000					
0008	0000	18		CLC		clear carry flag
0009	0001	FB		XCE		exchange carry with E bits (clear E bit)
0010	0002					
0011	0002			;	main example code	
0012	0002					
0013	0002	E220		SEP #%	00100000	set 8-bit data mode
0014	0004	AD0D00		LDA	SOURCE	load byte from memory location SOURCE
0015	0007	8D0E00		STA	DEST	store byte to memory location DEST
0016	000A					
0017	000A			;	code to return to 6502 emulation mode	
0018	000A					
0019	000A	38		SEC		set carry flag
0020	000B	FB		XCE		exchange carry with E bit (set E bit)
0021	000C			;		
0022	000C	60		RTS		
0023	000D					
0024	000D	77	SOURCE	DC	H'77'	
0025	000E	00	DEST	DS	1	
0026	000F					
0027	000F			END		

**Listing 6.1.**

Note that the source data in the define constant statement is now two bytes long, as is storage reserved by the define storage statement that follows. If you look at the interlisted hexadecimal code generated by the assembler, you will see that the address of the label **DEST** is now \$200F. The assembler has automatically adjusted for the increase in the size of the data at **SOURCE**, which is the great advantage of using symbolic labels rather than fixed addresses in writing assembler programs.

The load and store instructions are paired here to demonstrate that, when using identical addressing modes, the load and store operations are symmetrical. In case, though, a value loaded into a register will be stored many instructions later, or never at all, or stored using an addressing mode different from that of the load instruction.



0001	0000			KEEP KL.6.2		
0002	0000			65816 ON		
0003	0000					
0004	0000		MAIN	START		
0005	0000					
0006	0000			;		switch from 6502 emulation to native mode
0007	0000	18		CLC		
0008	0001	FB		XCE		
0009	0002			;		
0010	0002	C220		REP	00100000	reset accumulator to 16-bit mode
0011	0004	AD0D00		LDA	SOURCE	load double byte from memory location SOURCE
0012	0007	8D0F00		STA	DEST	store double byte to memory location DEST
0013	000A					
0014	000A			;		switch back to emulation mode
0015	000A	38		SEC		
0016	000B	FB		XCE		
0017	000C			;		
0018	000C	60		RTS		
0019	000D			;		
0020	000D	7F7F	SOURCE	DC	A'\$7F7F'	
0021	000F	0000	DEST	DS	2	
0022	0011			END		

Listing 6.2.

### *Effect of Load and Store Operations on Status Flags*

One of the results of the register load operations - **LDA**, **LDY**, and **LDX** - is their effect on certain **status flags** in the status register. When a register is loaded, the **n** and **z** flags are changed to reflect two conditions: whether the value loaded has its high bit set (is negative when considered as a signed, two's-complement number); and whether the number is equal to zero. The **n** flag is set when the value loaded is negative and cleared otherwise. The **z** flag is set when the value loaded is zero and cleared otherwise. How you use these status flags will be covered in detail in Chapter 8, Flow of Control.

The store operation does *not* change any flags, unlike the Motorola 68xx store instructions. On the other hand, Intel 808x programmers will discover the 65x processors use load and store instructions instead of the 808x's all-encompassing **MOV** instruction. The 808x move instruction changes no flags whatsoever, unlike the 65x load instruction, which does.

### *Moving Data Using the Stack*

All of the 65x processors have a single stack pointer. (This is a typical processor design, although there are designs that feature other stack implementations, such as providing separate stack pointers for the system supervisor and the user.) This single stack is therefore used both by the system for automatic storage of address information during subroutine calls and of address and register information during interrupts, and by user programs for temporary storage of data. Stack use by the system will be covered in later chapters.

As the architecture chapters in Part II discussed. The **S** register (stack pointer) points to the next available stack location; that is, **S** holds the address of the next available stack location. Instructions using stack addressing locate their data storage either at or relative to the next available stack location.

The stack pointers of the 6502 and 65C02 are only eight bits wide; the eight-bit value in the stack pointer is added to an implied base of \$100, giving the actual stack memory of \$100 to \$1FF; the stack is confined to page one. The 65816's native mode stack pointer, on the other hand, is sixteen bits wide, and may point to any location in bank zero (the first 64K of memory). The difference is illustrated in Figure 6.1.

## The Western Design Center

### *Push*

**Push** instructions store data, generally located in a register, onto the stack. Regardless of a register's size, the instruction that pushes it takes only a single byte.

When a byte is pushed onto the stack, it is stored to the location pointed to by the stack pointer, after which the stack pointer is automatically decremented to point to the next available location.

When double-byte data or a sixteen-bit address is pushed onto the stack, first its high-order byte is stored to the location pointed to by the stack pointer, the stack pointer is decremented, the low byte is stored to the new location pointed to by the stack pointer, and finally the stack pointer is decremented once again, pointing *past* both bytes of pushed data. The sixteen-bit value ends up on the stack in the usual 65x memory order: low byte in the lower address, high byte in the higher address.

In both cases, the stack grows downward, and the stack pointer points to the next available (unused) location at the end of the operation.

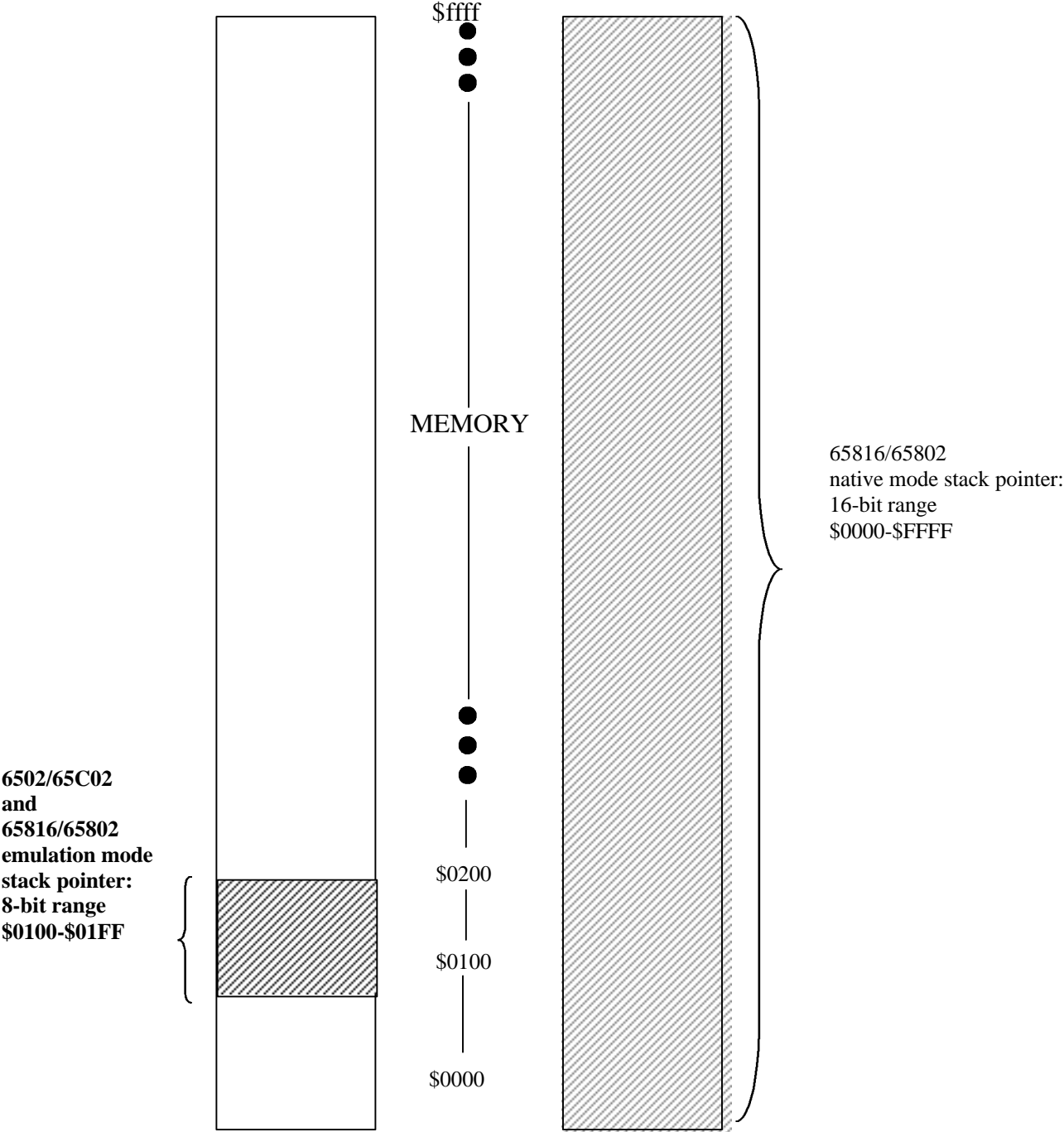

Figure 6-1 Stack Memory

### *Pushing the Basic 65x Registers*

On the 6502, only the contents of the accumulator and the status register can be pushed directly onto the stack in a single operation, using the **PHA** and **PHP** instructions, respectively. The 65C02 adds instructions to push the index registers onto the stack: **PHX** and **PHY**.

The 65816 and 65802 let double-byte data as well as single bytes be pushed onto the stack. Figure 6.2 shows the results of both. In the case of the accumulator and index registers, the size of the data pushed onto the stack depends on the settings of the **m** memory/accumulator select and **x** index register select flags. Since the accumulator and index registers are of variable size (eight bits or sixteen), the **PHA**, **PHX**, and **PHY** instructions have correspondingly variable effects.

### *Pull*

**Pull** instructions reverse the effects of the push instructions, but there are fewer pull instructions, all of them single-bit instructions that pull a value off the stack into a register. Unlike the Motorola and Intel processors (68xx and 808x), the 65x pull instructions set the **n** and **z** flags. So programmers used to using pull instructions between a test and a branch on the other processors should exercise caution with the 65x pull instructions.

### *Pulling the Basic 65x Registers*

The 6502 pull instructions completely complement its push instructions. **PLP** increments the stack pointer, then loads the processor status register (the flags) from the page one address pointed to by the offset in the stack pointer (of course, this destroys the previous contents of the status register). **PLA** pulls a byte from the stack into the accumulator, which affects the **n** and **z** flags in the status register just as a load accumulator instruction does.

As instructions for pushing the index registers were added to the 65C02, complementary pull instructions were added, too - that is, **PLX** and **PLY**. The pull index register instructions also affect the **n** and **z** flags.

On the 65802 and 65816, the push and pull instructions for the primary user registers - **A**, **X**, and **Y** - have been augmented to handle sixteen-bit data when the appropriate select flag (memory/accumulator or index register) is clear. Code these three pull instructions carefully since the stack pointer will be incremented one or two bytes per pull depending on the current settings of the **m** and **x** flags.

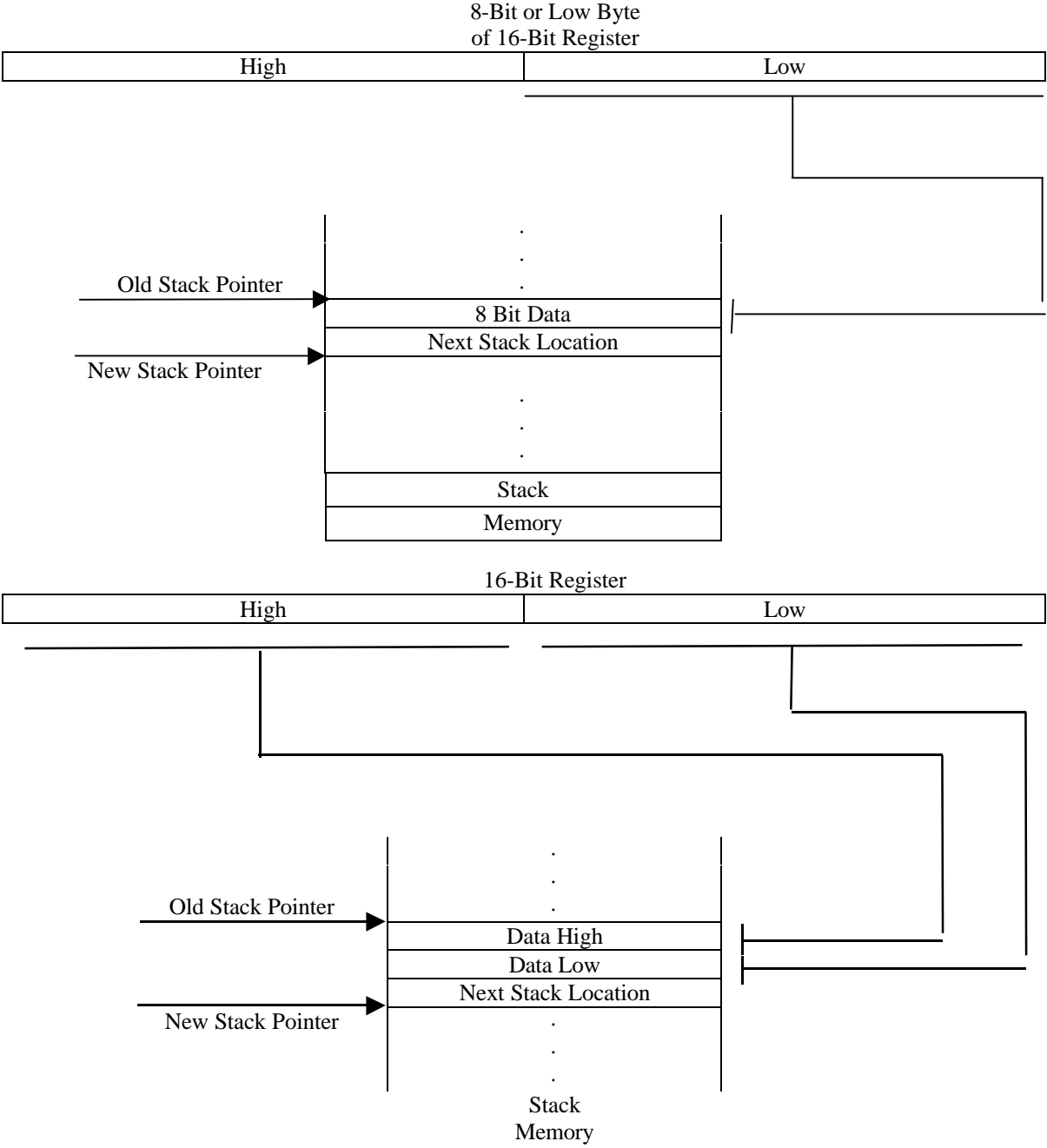

Figure 6-2. Push

*Pushing and Pulling the 65816's Additional Registers*

The 65816 adds one-byte push instructions for all its new registers, and pull instructions for all but one of them. In fact, the bank registers can only be accessed using the stack. **PHB** pushes the contents of the data bank register, an eight-bit register, onto the stack. **PLB** pulls an eight-bit value from the stack into the data bank register. Two most common uses for **PHB** are, first, to let a program determine the currently active data bank, and second, to save the current data bank prior to switching to another bank.

Fragment 6.1 is a 65816 code fragment which switches between two data banks. While **OTHBNK** is declared just once, it represents two different memory cells, both with the same sixteen-bit address of \$FFF3, but in two different 64K banks: one is in the data bank that is current when the code fragment is entered; the second is in the data bank switched to by the code fragment. The code fragment could be executed a second time and the data bank would be switched back to the original bank.

0000		OTHBNK	GEQU	\$FFF3	location of other bank stored here
0000					
0000			.		
0000			.		
0000			.		
0000	E220		SEP	##%00100000	set accumulator to 8-bit mode
0002					
0002	ADF3FF		LDA	OTHBNK	get location of bank to switch to
0005					
0005	8B		PHB		push current data bank onto stack
0006	48		PHA		push other data bank onto stack
0007					
0007	AB		PLB		pull data bank: make other data bank current
0008	68		PLA		get original data bank into accum
0009					
0009	8DF3FF		STA	OTHBNK	store it in 2 <sup>nd</sup> bank so can be restored
000C			.		
000C			.		
000C			.		
000C			.		

**Fragment 6.1.**

Similar to **PHB**, the **PHK** instruction pushes the value in the eight-bit program counter bank register onto the stack. Again, the instruction can be used to let you locate the current bank; this is useful in writing bank-independent code, which can be executed out of any arbitrarily assigned bank.

You're less likely to use **PHK** to preserve the current bank prior to changing banks (as in the case of **PHB** above) because the **jump to subroutine long** instruction automatically pushes the program counter bank as it changes it, and because there is no complementary pull instruction. The only way to change the value in the program counter bank register is to execute a long jump instruction, and interrupt, or a return from subroutine or interrupt. However, you can use **PHK** to synthesize more complex call and return sequences, or to set the data bank equal to the program bank.

Finally, the **PHD** instruction pushes the sixteen-bit direct page register onto the stack, and **PLD** pulls a sixteen-bit value from the stack into the direct page register. **PHD** is useful primarily for preserving the direct page location before changing it, while **PLD** is an easy way to change or restore it. Note that **PLB** and **PLD** also affect the **n** and **z** flags.

## The Western Design Center

### *Pushing Effective Addresses*

The 65816 also provides three instructions which can push data onto the stack without altering any registers. These three **push effective address** instructions - **PEA**, **PEI**, and **PER** - push absolute, indirect, and relative sixteen-bit addresses or data directly onto the stack from memory. Their use will be explained when their addressing modes are presented in detail in Chapter 11 (Complex Addressing Modes).

### *Other Attributes of Push and Pull*

The types of data that can be pushed but not pulled are effective addresses and the **K** (or more commonly **PBR**) program bank register.

**PLD** and **PLB** are typically used to restore values from a previous state.

Finally, you should note that even though the push and pull operations are largely symmetrical, data that is pushed onto the stack from one register does not need to be pulled off the stack into the same register. As far as the processor is concerned, data pulled off the stack does not have to be the same size as was pushed onto it. But needless to say, the stack can quickly become garbled if you are not extremely careful.

## Moving Data Between Registers

### *Transfers*

The accumulator is the most powerful of the user registers, both in the addressing modes available to accumulator operations and in its arithmetic and logic capabilities. As a result, addresses and indexes that must be used in one of the index registers must often be calculated in the accumulator. A typical problem on the 6502 and 65C02, since their registers are only eight bits wide, is that sixteen-bit values such as addresses must be added or otherwise manipulated eight bits at a time. The other half of the value, the high or low byte, must meanwhile be stored away for easy retrieval and quick temporary storage of register contents in a currently unused register is desirable.

For these reasons as well as to transfer a value to a register where a different operation or addressing mode is available, all 65x processors implement a set of one-byte implied operand instructions which transfer data from one register to another:

<b>TAX</b>	transfers the contents of the accumulator to the <b>X</b> index register
<b>TAY</b>	transfers the contents of the accumulator to the <b>Y</b> index register
<b>TSX</b>	transfers the contents of the stack pointer to the <b>X</b> index register
<b>TXS</b>	transfers the contents of the <b>X</b> index register to the stack pointer
<b>TXA</b>	transfers the contents of the <b>X</b> index register to the accumulator
<b>TYA</b>	transfers the contents of the <b>Y</b> index register to the accumulator

Like the load instructions, all of these transfer operations except **TXS** set both the **n** and **z** flags. (**TXS** does not affect the flags because setting the stack is considered an operation in which the data transferred is fully known and will not be further manipulated.)

The availability of these instructions on the 65802/65816, with its dual-word-size architecture, naturally leads to some questions when you consider transfer of data between registers of different sizes. For example, you may have set the accumulator word size to sixteen bits, and the index register size to eight. What happens when you execute a **TAY** (transfer **A** to **Y**) instruction?

The first rule to remember is that the nature of the transfer is determined by the *destination* register. In this case, only the low-order eight bits of the accumulator will be transferred to the eight-bit **Y** register. A second rule also applies here: when the index registers are eight bits (because the index register select flag is set), the high byte of each index register is always forced to zero upon return to sixteen-bit size, and the low-order value of each sixteen-bit index register contains its previous eight-bit value.

Listing 6.3 illustrates these rules with **TAY**. In this example, the value stored at the location **DATA2** is \$0033; only the low order byte has been transferred from the accumulator, while the high byte has been zeroed.

The accumulator, on the other hand, operates differently. When the accumulator word size is switched from sixteen bits to eight, the high-order byte is preserved in a “hidden” accumulator, **B**. It can even be

## The Western Design Center

accessed without changing modes back to the sixteen-bit accumulator size by executing the **XBA** (exchange **B** with **A**) instructions, described in the following section. Listing 6.4 illustrates this persistence of the accumulator's high byte. After running it, the contents of locations **RESULT**. **RESULT+1** will be \$7F33, or 33 7F, in low-high memory order. In other words, the value in the high byte of the sixteen-bit accumulator, \$7F, was preserved across the mode switch to eight-bit word size.

Now consider the case where the sixteen-bit **Y** register is transferred to an eight-bit accumulator, as shown in Listing 6.5. The result in this case is \$33FF, making it clear that the high byte of the **Y** register has not been transferred into the inactive high-order byte of the accumulator. The rule is that operations on the eight-bit **A** accumulator affect only the low-order byte in **A**, not the hidden high byte in **B**. Transfers into the **A** accumulator fall within the rule.

Figure 6.3 summarizes the effects of transfers between registers of different sizes.

0001	0000			KEEP	KL.6.3	
0002	0000					
0003	0000			65816	ON	
0004	0000					
0005	0000					
0006	0000		MAIN	START		
0007	0000		;	switch-to-native-mode code		
0008	0000	18		CLC		clear carry flag
0009	0001	FB		XCE		exchange carry with e bit (clear e bit)
0010	0002					
0011	0002	C220		REP	#\$20	set accum to 16
0012	0004	E210		SEP	#\$10	set index to 8
0013	0006	AD1200		LDA	DATA	
0014	0009	A8		TAY		
0015	000A	C210		REP	#\$10	set index to 16
0016	000C	8C1400		STY	DATA2	
0017	000F					
0018	000F		;	return to 6502 emulation mode		
0019	000F	38		SEC		set carry flag
0020	0010	FB		XCE		exchange carry with e bit (set e bit)
0021	0011					
0022	0011	60		RTS		
0023	0012					
0024	0012	33FF	DATA	DC	A'\$FF33'	
0025	0014	0000	DATA2	DS	2	
0026	0016					
0027	0016			END		

**Listing 6.3.**

There are also rules for transfers from eight-bit to a sixteen-bit register. Transfers out of the eight-bit accumulator into a sixteen-bit index register transfer both eight-bit accumulators.

In Listing 6.6, the value saved to **RESULT** is \$7FFF, showing that not only is the eight-bit **A** accumulator transferred to become the low byte of the sixteen-bit index register, but the hidden **B** accumulator is transferred to become the high byte of the index register. This means you can form a sixteen-bit index in the eight-bit accumulator one byte at a time, then transfer the whole thing to the index register without having to then transfer the whole thing without having to switch the accumulator to sixteen bits first. However, take care not to inadvertently transfer an unknown hidden value when doing transfers from the eight-bit accumulator to a sixteen-bit index register.



## The Western Design Center

0001	0000			KEEP	
0002	0000			65816	
0003	0000				
0004	0000		MAIN	START	
0005	0000				
0006	0000			;	switch-to-native-mode code
0007	0000	18		CLC	clear carry flag
0008	0001	FB		XCE	exchange carry with e bit (clear e bit)
0009	0002				
0010	0002	C230		REP	#\$30 set accum and index size to 16
0011	0004	AD1400		LDA	DATA16 load accum with 16-bit value at DATA16
0012	0007	E220		SEP	#\$20 set accum to eight bits
0013	0009	AD1600		LDA	DATA8 load 8-bit value at DATA8
0014	000C	C220		REP	#\$20 make accum 16 again
0015	000E	8D1700		STA	RESULT save accum lo.hi in RESULT.RESULT+1
0016	0011				
0017	0011			;	return to 6502 emulation mode
0018	0011	38		SEC	set carry flag
0019	0012	FB		XCE	exchange carry with e bit (set e bit)
0020	0013				
0021	0013	60		RTS	
0022	0014				
0023	0014	FF7F	DATA16	DC	A'\$7FFF'
0024	0016	33	DATA8	DC	H'33'
0025	0017	0000	RESULT	DS	2
0026	0019				
0027	0019			END	

**Listing 6.4**

## The Western Design Center

Transfers from eight-bit index register to the sixteen-bit accumulator result in the index register being transferred into the accumulator's low byte while the accumulator's high byte is zeroed. This is consistent with the zeroing of the high byte when eight-bit index registers are switched to sixteen bits.

In Listing 6.7, the result is \$0033, demonstrating that when an eight-bit index register is transferred to the sixteen-bit accumulator, a zero is concatenated as the high byte of the new accumulator value.

0001	0000			KEEP	KL.6.5	
0002	0000			65816	ON	
0003	0000					
0004	0000		MAIN	START		
0005	0000					
0006	0000		;	switch to native mode		
0007	0000					
0008	0000	18		CLC		clear carry flag
0009	0001	FB		XCE		exchange carry with e bit (clear e bit)
0010	0002					
0011	0002	C230		REP	#\$30	set accum, index size to 16
0012	0004	AC1500		LDY	DATA16	load Y-reg with 16-bit value at DATA16
0013	0007	AD1700		LDA	DATA2	load accum with 16-bit value at DATA2
0014	000A	E220		SEP	#\$20	set accum to eight bits
0015	000C	98		TYA		transfer Y register's value to A
0016	000D	C220		REP	#\$20	make accum 16 again
0017	000F	8D1900		STA	RESULT	save accum lo.hi in RESULT>RESULT+1
0018	0012					
0019	0012		;	return to 6502 emulation mode		
0020	0012					
0021	0012	38		SEC		set carry flag
0022	0013	FB		XCE		exchange carry with e bit (set e bit)
0023	0014					
0024	0014	60		RTS		
0025	0015					
0026	0015	FF7F	DATA16	DC	A'\$7FFF'	
0027	0017	4433	DATA2	DC	A'\$3344'	
0028	0019	0000	RESULT	DS	2	
0029	001B					
0030	001B			END		

**Listing 6.5.**

In the 65816, transfers between index registers and the stack also depend on the setting of the *destination* register. For example, transferring the sixteen-bit stack to an eight-bit register, as in Fragment 6.2, results in the transfer of just the low byte. Obviously, though, you'll find few reasons to transfer only the low byte of the sixteen-bit stack pointer. **As always, you need to be watchful of the current modes in force in each of your routines.**

The 65816 also adds new transfer operations to accommodate direct transfer of data to and from the new 65816 environment-setting registers (the direct page register and the sixteen-bit stack register), and also to complete the set of possible register transfer instructions for the basic 65x user register set:

**The Western Design Center**

(L = bits in low byte; H = bits in high byte; P = previous bits unmodified by transfer)

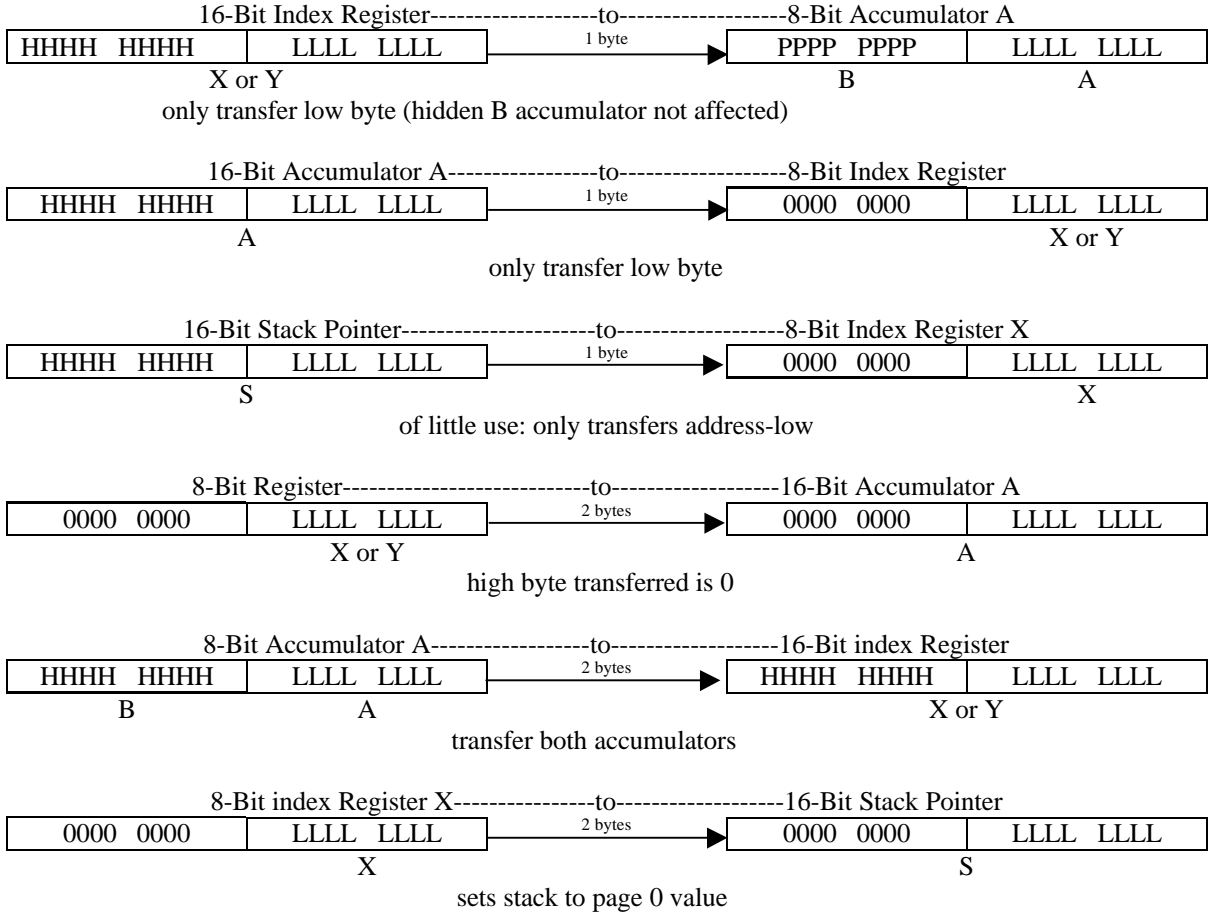

**Figure 6-3 Register Transfers Between Different-Sized Registers**

**The Western Design Center**

0001	0000			KEEP	KL.6.6	
0002	0000			65816	ON	
0003	0000					
0004	0000		MAIN	START		
0005	0000					
0006	0000		;	switch to native mode		
0007	0000					
0008	0000	18		CLC		clear carry flag
0009	0001	FB		XCE		exchange carry with e bit (clear e bit)
0010	0002					
0011	0002	C230		REP	#\$30	set accum, index size to 16 bits
0012	0004	AD1300		LDA	DATA16	load accum with 16-bit value at DATA16
0013	0007	AC1500		LDY	DATA2	load Y-reg with 16-bit value at DATA2
0014	000A	E220		SEP	#\$20	set accum to eight bits
0015	000C	A8		TAY		transfer accum to Y
0016	000D	8C1700		STY	RESULT	save 16-bit index into RESULT.RESULT+1
0017	0010					
0018	0010		;	return to 6502 emulation mode		
0019	0010					
0020	0010	38		SEC		set carry flag
0021	0011	FB		XCE		exchange carry with e bit (set e bit)
0022	0012					
0023	0012	60		RTS		
0024	0013					
0025	0013					
0026	0013	FF7F	DATA16	DC	A'\$7FFF'	
0027	0015	4433	DATA2	DC	A'\$3344'	
0028	0017	0000	RESULT	DS	2	
0029	0019					
0030	0019			END		

**Listing 6.6**

0001	0000		KEEP	KL.6.7	
0002	0000		65816	ON	
0003	0000				
0004	0000				
0005	0000	MAIN	START		
0006	0000				
0007	0000	;	switch-to-native-mode	code	
0008	0000				
0009	0000	18	CLC		clear carry flag
0010	0001	FB	XCE		exchange carry with e bit (clear e bit)
0011	0002				
0012	0002	E210	SEP	#\$10	set index size to 8 bits
0013	0004	C220	REP	#\$20	set accum to 16 bits
0014	0006	AD1300	LDA	DATA16	load accum with 16-bit value at DATA16
0015	0009	AC1500	LDY	DATA8	load Y-reg with 8-bit value at DATA8
0016	000C	98	TYA		transfer Y to accumulator
0017	000D	8D1600	STA	RESULT	save 16-bit accum into RESULT.RESULT+1
0018	0010				
0019	0010	;	return to 6502 emulation	mode	
0020	0010				
0021	0010	38	SEC		set carry flag
0022	0011	FB	XCE		exchange carry with e bit (set e bit)
0023	0012				
0024	0012	60	RTS		
0025	0013				
0026	0013				
0027	0013	FF7F	DATA16	DC	A'\$7FFF'
0028	0015	33	DATA8	DC	H'33'
0029	0016	0000	RESULT	DS	2
0030	0018				
0031	0018		END		

Listing 6.7

0000	E210	SEP	##%00010000	set index mode to 8 bits
0002	BA	TSX		transfer low byte of stack ptr to 8-bit x

Fragment 6.2

- TCD** transfers the contents of the sixteen-bit accumulator C to the D direct page register. The use of the letter C in this instruction's mnemonic to refer to the accumulator indicates that this operation is always is a sixteen-bit transfer, regardless of the setting of the memory select flag. For such a transfer to be meaningful, of course, the high-order byte of the accumulator must contain a valid value.
- TDC** transfer the contents of the D direct page register to the sixteen-bit accumulator. Again, the use of the letter C in the mnemonic to name the accumulator indicates that the sixteen-bit accumulator is always used, regardless of the setting of the memory select flag. Thus, sixteen bits are always transferred, even if the accumulator size is eight bits, in which case the high byte is stored to the hidden B accumulator.
- TCS** transfers the contents of the sixteen-bit C accumulator to the S stacker pointer register, thereby relocating the stack. Since sixteen bits will be transferred regardless of the accumulator word size, the high byte of the accumulator must contain valid data.
- TSC** transfer the contents of the sixteen-bit S stacker pointer register to the sixteen-bit accumulator, C, regardless of the accumulator word size.
- TXY** transfers the contents of the X index register to the Y index register. Since X and Y will always have the same register size, there is no ambiguity.
- TYX** transfers the contents of the Y index register to the X index register. Both will always be the same size.

## The Western Design Center

Transfer instructions take only one byte, with the source and destination both specified in the opcode itself. In all transfers, the data remains intact in the original register as well as being copied into the new register.

Using **TCS** and **TCD** can be dangerous when the accumulator is in eight-bit mode, unless the accumulator was recently loaded in sixteen-bit mode so that the high byte, hidden when the switch was made to eight-bit mode, is still known. Transferring an indeterminate hidden high byte of the accumulator along with its known low byte into a sixteen-bit environment register such as the stack pointer will generally result in disaster.

As always, you need to be watchful of the modes currently in force in each of your routines.

## Exchanges

The 65802 and 65816 also implement two exchange instructions, neither available on the 6502 or 65C02. An exchange differs from a transfer in the two values are swapped, rather than one value being copied to a new location.

The first of the two exchange instructions, **XBA**, swaps the high and low bytes of the sixteen-bit accumulator (the **C** accumulator).

The terminology used to describe the various components of the eight-or-sixteen bit accumulator is: to use **A** to name the accumulator as a register that may be optionally eight or sixteen bits wide (depending on the **m** memory/accumulator select flag); to use **C** when the accumulator is considered to be sixteen bits regardless of the setting of the **m** flag; and, when **A** is used in eight-bit mode to describe the low byte only, to use **B** to describe the hidden high byte of the sixteen-bit accumulator. In the latter case, when the accumulator size is set to eight bits, only the **XBA** instruction can directly access the high byte of the sixteen-bit “double accumulator”, **B**. This replacement of **A** for **B** and **B** for **A** can be used to simulate two eight-bit accumulators, each of which, by swapping, “shares” the actual **A** accumulator. It can also be used in the sixteen-bit mode for inverting a double-byte value. The **XBA** instruction is exceptional in that the **n** flag is always set on the basis of bit seven of the resulting accumulator **A**, even if the accumulator is sixteen bits.

The second exchange instruction, **XCE**, is the 65816’s only, method for toggling between 6502 emulation mode and 65816 native mode. Rather than exchange register values, it exchanges two-bits - the carry flag, which is bit zero of the status register, and the **e** bit, which should be considered a kind of appendage to the status register and which determines the use of several of the other flags.

Fragment 6.3 sets the processor to 6502 emulation mode. Conversely, native mode can be set by replacing the **SEC** with a **CLC** clear carry instruction.

0010 38	SEC
0011 FB	XCE

**Fragment 6.3**

Because the exchange stores the previous emulation flag setting into the carry, it can be saved and restored later. It can also be evaluated with the branch-on-condition instructions to be discussed in Chapter 8 (Flow of Control) to determine which mode the processor was just in. A device driver routine that needs to set the emulation bit, for example, can save its previous value for restoration before returning.

The selection of the carry flag for the **e** bit exchange instruction is in no way connected to the normal use of the carry flag in arithmetic operations. It was selected because it is easy to set and reset, it is less frequently used than the sign and zero flags, and there are branch-on-conditions instructions which test it. The primary use of the **SEC** and **CLC** instructions for arithmetic will be covered in upcoming chapters.

## Storing Zero to Memory

The **STZ** instructions, introduced on the 65C02, lets you clear either a single or double byte memory word zero, depending, as usual, on the current memory/accumulator select flag word size. Zero has long been recognized as one of the most commonly stored values, so a “dedicated” instruction to store zero to memory can improve the efficiency of many 65x programs. Furthermore, the **STZ** instruction lets you clear memory without having to first load one of the registers with zero. Using **STZ** results in fewer bytes of code, faster execution, and undisturbed registers.

## The Western Design Center

### Block Moves

The two block move instructions, available only on the 65802 and the 65816, let entire blocks (or strings) of memory be moved at once.

Before using either instruction, all three user registers (**C**, **X**, and **Y**) must be set up with values which serve as parameters.

The **C** accumulator holds the count of the number of bytes to be moved, *minus one*. It may take some getting used to, but this “count” is numbered from zero rather than one. The **C** accumulator is always sixteen bits: if the **m** mode flag is set to eight bits, the count is still the sixteen-bit value in **C**, the concatenation of **B** and **A**.

**X** and **Y** specify either the top or the bottom addresses of the two blocks, depending on which of the two versions of the instruction you choose. In Listing 6.8, \$2000 bytes of data are moved from location \$2000 to \$4000.

0001	0000			KEEP	KL.6.8	
0002	0000			65816	ON	
0003	0000					
0004	0000		MAIN	START		
0005	0000					
0006	0000	18		CLC		
0007	0001	FB		XCE		
0008	0002					
0009	0002	C230		REP	#\$30	reset data and index mode to 16 bits
0010	0004			LONGA	ON	
0011	0004			LONGI	ON	
0012	0004					
0013	0004	AD1300		LDA	COUNT	load 16-bit C accum with # bytes to be moved
0014	0007	AE1500		LDX	SOURCE	load 16-bit X reg with address of source
0015	000A	AC1700		LDY	DEST	load 16-bit Y reg with address of destination
0016	000D					
0017	000D	540000		MVN	0,0	
0018	0010					
0019	0010	38		SEC		
0020	0011	FB		XCE		
0021	0012	60		RTS		
0022	0013					
0023	0013	FF1F	COUNT	DC	A'\$1FFF'	
0024	0015	0020	SOURCE	DC	A'\$2000'	
0025	0017	0040	DEST	DC	A'\$4000'	
0026	0019					
0027	0019			END		

**Listing 6.8.**

The **MVN** instruction uses **X** and **Y** to specify the bottom (or beginning) addresses of the two blocks of memory. The first byte is moved from the address in **X** to the address in **Y**; then **X** and **Y** are incremented, **C** is decremented, and the next byte is moved, and so on, until the number of bytes specified by the value in **C** is moved (that is, until **C** reaches \$FFFF). If **C** is zero, a single first byte is moved, **X** and **Y** are each incremented once, and **C** is decremented to \$FFFF.

The **MVP** instruction assumes **X** and **Y** specify the top (or ending) addresses of the two blocks of memory. The first byte is moved from the address in **X** to the address in **Y**; the **X**, **Y** and **C** are decremented, the next byte is moved, and so on, until the number of bytes specified by the value in **C** is moved (until **C** reaches \$FFFF).

The need for two distinct block move instructions becomes apparent when the problem of **memory overlap** is considered. Typically, when a block of memory starting at location **X** is to be moved to location **Y**, the intention is to replace the memory locations from **Y** to **Y + C** with the identical contents of the range **X** through **X + C**. However, if these two ranges overlap, it is possible that as the processor blindly transfers memory one byte at a time, it may overwrite a value in the source range before that value has been transferred.

The rule of thumb is, when the destination range is a lower memory address than the source range, the **MVN** instruction should be used (thus “Move Next”) to avoid overwriting source bytes before they have been copied to the destination. When the destination range is a higher memory location than the source range, the **MVP** instruction should be used (“Move Previous”).

## The Western Design Center

While you could conceivably move blocks with the index registers set to eight bits (your only option in emulation mode), you could only move blocks in page zero to other page zero location. For all practical purposes, you must reset the **x** mode flag to sixteen bits before setting up and executing a block move.

Notice that assembling an **MVN** or **MVP** instruction generates not only an opcode, but also two bytes of operand. The operand bytes specify the 64K bank from which and to which data is moved. When operating in the 65816's sixteen-megabyte memory space, this supports the transfer of up to 64K of memory from one bank to another. In the object code, the first byte following the opcode is the bank address of the destination and the second byte is the bank address of the source.

But while this order provides microprocessor efficiency, assembler syntax has always been the more logical left to right, source to destination (**TAY**, for example, transfers the accumulator to the **Y** index register). As a result, the recommended assembler syntax is to follow the mnemonic first with a 24-bit source address then with a 24-bit destination address - or more commonly with labels representing code or data addresses. The assembler strips the bank byte from each address (ignoring the rest) and inserts them in the correct object code sequence. (Destination bank, source bank.) For example:

```
440102      MVP SOURCE, DEST           move from bank of source(02) to bank of dest(01)
```

The bank byte of the label **SOURCE** is 02 while the bank byte of the label **DEST** is 01. As always, the assembler does the work of converting the more human-friendly assembly code to the correct object code format for the processor.

If the source and destination banks are not specified, some assemblers will provide a user-specified default bank value.

The assembler will translate the opcode to object code, then supply its bank value for both of the operand bytes:

```
440000          MVP
```

If either bank is different from the default value, both must be specified.



# 7) Chapter Seven

## Simple Addressing Modes

The term **addressing mode** refers to the method by which the processor determines where it is to get the data needed to perform a given operation. The data used by a 65x processor may come either from memory or from one or another of the processor's register's. Data for certain operations may optionally come from either location, some from only one or the other. For those operations which take one of their operands from memory, there may be several ways of specifying a given memory location. The method best suited in a particular instance is a function of the overall implementation of a chosen problem-solving algorithm. Indeed, there are so many addressing modes available on the 65x processors that there is not necessarily a single "correct" addressing mode in each situation.

This chapter deals with those addressing modes which may be described as the "simple" addressing modes. You have already seen some of these used in the examples of the previous chapter; the simple addressing modes are listed in Table 7.1. Each of these addressing modes is straightforward. Those addressing modes that require more than a simple combination of values from several memory locations or registers are described as "complex modes" in Chapter 11.

<i>Available on all 65x processors:</i>		
	<i>Example</i>	<i>Syntax</i>
immediate	LDA	#\$12
absolute	LDA	\$1234
direct page (zero page)	LDA	\$12
accumulator	ASL	A
implied	TAY	
stack	PHA	
<i>Available on the 65C02, 65802, and 65816 only:</i>		
direct page (zero page) indirect	LDA	(\$12)
<i>Available on the 65802 and 65816 only:</i>		
absolute long	LDA	\$123456
direct page indirect long	LDA	[\$12]
block move	MVN	SOURCE, DEST

**Table 7-1 List of Simple Addressing Modes**

In addition to solving a given problem, the processor must spend a great deal of its time simply calculating effective addresses. The simple addressing modes require little or no effective address computation, and therefore tend to be the fastest executing. However, the problem-solving and memory efficiencies of the complex addressing modes, which will be described in subsequent chapters, can make up for their effective address calculation overhead. In each case, the nature of the problem at hand determines the best addressing mode to use.

## Immediate Addressing

Immediate data is data found embedded in the instruction stream of a program itself, immediately following the opcode which uses the data. Because it is part of the program itself, it is always a constant value, known at assembly time and specified when you create the program. Typically, small amounts of constant data are handled most efficiently by using the immediate addressing mode to load either the accumulator or an index register with specific value. Note that the immediate addressing mode is not available with any of the store instructions (**STA**, **STX**, or **STY**), since it makes no sense to *store* a value to the operand location within the code stream.

To specify the immediate addressing mode to a 65x assembler, prefix the operand with a # (pound or sharp) sign. The constant operand may be either data or an address.

For example,

```
A912                LDA    #$12
```

loads the hexadecimal value \$12 into the accumulator.

The 6502 and 65C02, their registers limited to only eight bits, permit only an eight-bit operand to follow the load register immediate opcodes. When the constant in an assembly source line is a sixteen-bit value, greater-than and less-than signs are used to specify whether the high- or low-order byte of the double-byte value are to be used. A less-than indicates that the low byte is to be used, and thus:

```
A234                LDX    #<$1234
```

causes the assembler to generate the **LDX** opcode followed by a one-byte operand, the low byte of the source operand, which is \$34. It's equivalent to:

```
A234                LDX    #$34
```

The use of a greater-than sign would cause the value \$12 to be loaded. If neither the less-than nor greater-than operator is specified, most assemblers will default to the low byte when confronted with a double-byte value.

When assembling 65816 source code, the problem becomes trickier. The 6502 and 65C02 neither have nor need an instruction to set up the eight-bit mode because they are always in it. But the 65816's accumulator may be toggled to deal with eight- or sixteen-bit quantities, as can its index registers, by setting or resetting the **m** (memory/accumulator select) or **x** (index select) flag bits of the status register. Setting the **m** bit puts the accumulator in eight-bit mode; resetting it puts it in sixteen-bit mode. Setting the **x** bit puts the index registers in eight-bit mode; resetting it puts them in sixteen-bit mode.

The **m** and **x** flags may be set and reset many times throughout a 65816 program. But while assembly code is assembled from beginning to end, it rarely executes in that fashion. More commonly, it follows a circuitous route of execution filled with branches, jumps, and subroutine calls. Except for right after the **m** or **x** flag has been explicitly set or reset, the assembler has no way of knowing the correct value of either: your program may branch somewhere, and re-enter with either flag having either value, quite possibly an incorrect one.

While the programmer must always be aware of the proper values of these two flags, for most instructions the assembler doesn't need to know their status in order to generate code. Most instructions generated are the same in both eight- or sixteen-bit mode. Assembling a load accumulator absolute instruction, for example, puts the same opcode value and the same absolute address into the code stream regardless of accumulator size; it is at execution time that the **m** bit setting makes a difference between whether the accumulator is loaded with one or two bytes from the absolute address.

But a load register immediate instruction is followed by the constant to be loaded. As Figure 7.1 shows, if the register is set to eight-bit mode at the point the instruction is encountered, the 65816 expects a one-byte constant to follow before it fetches the next opcode. On the other hand, if the register is set to sixteen-bit mode at the point the instruction is encountered, the 65816 expects a double-byte constant to follow before it fetches the next opcode. The assembler must put either a one-byte or two-byte constant operand into the code following the load register immediate opcode based on the status of a flag which it doesn't know.

**Immediate Addressing: 8 bit vs. 16**

**8-Bit Data [all processors]:** Data: operand byte.

**Instruction:**

Opcode	Data = Operand
--------	----------------

**16-Bit Data (65802/65816. native mode, applicable mode flag m or x=0)**

Data High: Second operand byte

Data Low: First operand byte

**Instruction:**

Opcode	Data Low = Operand Low	Data High = Operand High
--------	---------------------------	-----------------------------

**Figure 7-1 Immediate Addressing: 8 vs. 16 bits**

Two assembler directives have been designed to tell the assembler which way to go: **LONGA** and **LONGI**, each followed with the value **ON** or **OFF**. **LONGA ON** indicates the accumulator is in sixteen-bit mode, **LONGA OFF** in eight-bit mode. **LONGI ON** tells the assembler that the index registers are in sixteen-bit mode, **LONGI OFF** that they are in eight-bit mode. Load register immediate instructions are assembled on the basis of the last **LONGA** or **LONGI** directive the assembler has seen - that is, the one most immediately preceding it in the source file. For example,

```
LONGA ON
LONGI ON
```

tells the assembler that both accumulator and index registers are set to sixteen bits. Now, if it next encounters the following two instructions

```
A93412          LDA    #$1234
A05600          LDY    #$56
```

then the first puts a **LDA** immediate opcode followed by the constant \$1234 into the code, and the second a **LDY** immediate opcode followed by the constant \$0056, again two bytes of operand, the high byte padded with zero.

On the other hand,

```
LONGA OFF
LONGI OFF
```

tells the assembler that both accumulator and index registers are set to eight bits. Now,

```
A934           LDA    #$1234
A056           LDY    #$56
```

puts **LDA** immediate opcode followed by the constant \$34 into code, and the second a **LDY** immediate opcode followed by the constant \$56, each one byte of operand.

Like the flags themselves, of course, one directive may be **ON** and the other **OFF** at any time. They also do not need to both be specified at the same time.

The setting of the **LONGA** and **LONGI** directives to either **ON** or **OFF** simply represent a promise by you, the programmer, that the flags will, in fact, have these values at execution time. The directives do nothing by themselves to change the settings of the actual **m** and **x** flags; this is typically done by using the **SEP** and **REP** instructions, explained earlier. (Note, incidentally, that these two instructions use a special form of the immediate addressing mode, where the operand is always eight bits.) Nor does setting the flags change the

## The Western Design Center

settings of the directives. You must therefore exercise to set the **LONGA** and **LONGI** flags to correctly represent the settings of the **m** or **x** flags, and to be sure never to branch into the code with the **m** or **x** flag set differently. If, for example, the assembler generated a **LDA #1234** instruction with **LONGA** set **ON**, only to have the **m** accumulator flag set to eight bits when the code is executed, the processor would load the accumulator with \$34, then see the \$12 which follows as the next opcode and try to execute it, resulting in program failure.

## Absolute Addressing

There are two categories of simple addressing modes available for accessing data in a known memory location: absolute and direct page. The first of these, absolute addressing, is used to load or store a byte to or from a fixed memory location (within the current 65K data bank on the 65816, which defaults to bank zero on power up). You specify the sixteen-bit memory location in the operand field (following the opcode) in your assembly language source line, as Figure 7.1 loads the eight-bit constant \$34 into the accumulator, then stores it to memory location \$B100 in the current data bank.

0000	E220	SEP	00100000	set 8-bit accumulator/memory mode
0002		LONGA	OFF	tell assembler the accumulator mode
0002	A934	LDA	\$34	load constant \$34 as immediate data
0004	8D00B1	STA	\$B100	store byte to memory location \$B100

**Fragment 7.1.**

The same memory move could be done with either of the index registers, as shown in Fragment 7.2 using the **X** register. Symbolic labels in the operand fields provide better self-documentation and easier program modification.

0000		NUM1	GEQU	\$34	give this data byte a symbolic label
0000		DATA	GEQU	\$B100	give this data byte a symbolic label
0000					
0000	E210	SEP	00010000	set index registers to 8-bit mode	
0002		LONGI	OFF	tell assembler the index mode is 8-bit	
0002	A234	LDX	NUM1	load constant \$34 as immediate data	
0004	8E00B1	STX	DATA	store byte to memory location \$B100	

**Fragment 7.2**

As you have seen, the 65816's accumulator may be toggled to deal with either eight- or sixteen-bit quantities, as can its index registers, by setting or resetting the **m** or **x** flag bits of the status register. Naturally, you don't need to execute a **SEP** or **REP** instructions nor a **LONGA** or **LONGI** assembler directive before every routine, provided you know the register you intend to use is already set correctly, and the assembler correctly knows that the setting. But you must always exercise extreme care when developing 65816 programs to avoid making invalid assumptions about the modes currently in force or taking unintentional branches from code in one mode to code in another.

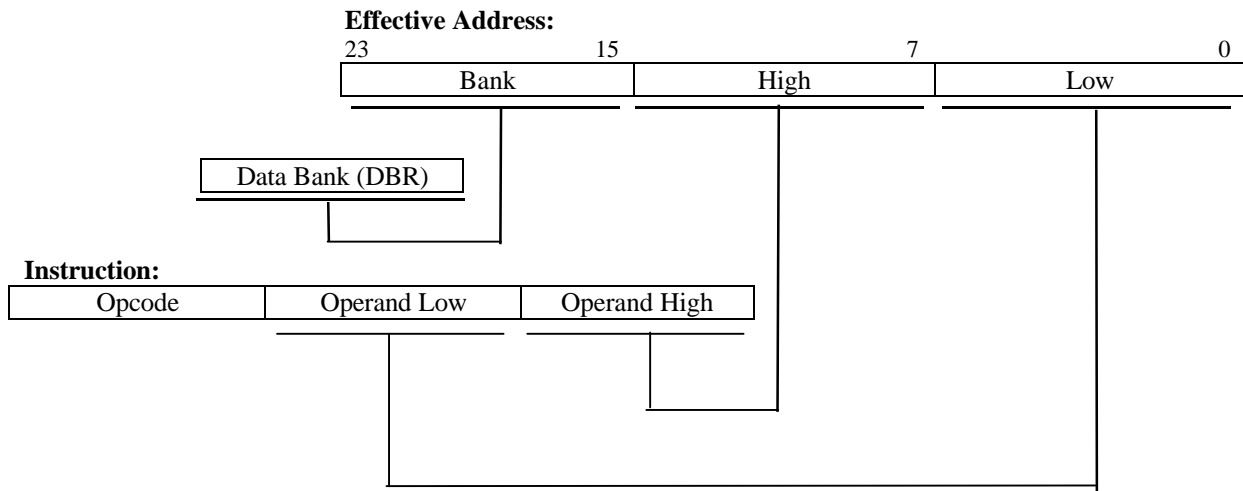

Figure 7-2 Absolute Addressing

As Fragment 7.3 shows, the load and store instructions above will as easily move sixteen bits of data as they did eight bits; all that's needed is to be sure the register used is in sixteen-bit mode, and that the assembler has alerted to the setting.

0000	DATA	GEQU	\$B100	give this location a symbolic label
0000				
0000	C210	REP	##00010000	reset index registers to 16-bit mode
0002		LONGI	ON	tell assembler
0002	A23412	LDX	#1234	load 16-bit constant \$1234 immediate
0005	8E00B1	STX	DATA	store double byte to memory loc \$B100

Fragment 7.3.

As indicated, absolute addresses are sixteen-bit addresses. On the 6502, 65C02, and 65802, with memory space limited to 64K, sixteen bits can specify any fixed location within the entire address space of the processor. Therefore, the term **absolute addressing** was appropriate.

The 65816, on the other hand, with its segmentation into 256 possible 64K banks, requires a 24-bit address to specify any fixed location within its address space. However, the same opcodes that generate 24-bit addresses on the 65816 by concatenating the value of the data bank register with the sixteen-bit value in the operand field of the instruction. (Instructions that transfer control, to be discussed in Chapter 8, substitute the program bank register value for the data bank register value.)

Absolute addressing on the 65816 is therefore actually an offset from the base of the current bank; nevertheless, the use of the term absolute addressing has survived on the 65816 to refer to sixteen-bit fixed addresses within the current 64K data bank.

So long as the programmer needs to access only the contents of the current data bank, (sixteen-bit) absolute addressing is the best way to access data at any known location in that bank.

### Direct Page Addressing

One of the most powerful and useful features of the 6502 and 65C02 processors is their zero page addressing modes. A **page** of memory on a 65x processor consists of 256 memory locations, starting at an address which is an integer multiple of \$100 hexadecimal, that is, \$0000, \$0100, \$0200, and so on. Generally, pages are numbered in hexadecimal, so their range within a 64K bank is \$00 through \$FF. **Zero page** addressing is made even more powerful and generalized as **direct page addressing** on the 65802 and 65816.

The zero page is the first of the 256 pages found within the 64K address space of the 6502 and 65C02 - memory addresses \$0000 to \$00FF. These addresses may be accessed one byte cheaper than absolute memory accesses. Whereas loading or storing data from an absolute location will require three bytes of code, loading or storing a byte from a zero page location requires only two bytes, as Figure 7.3 shows.

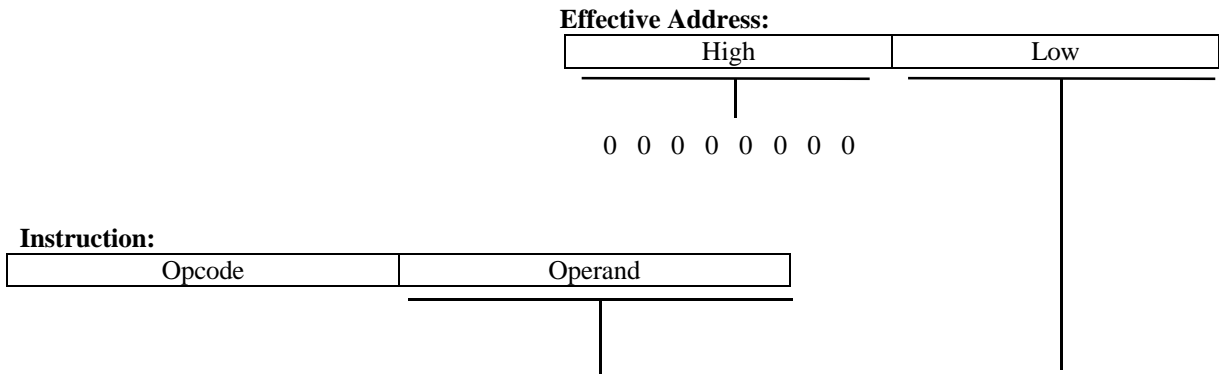

Figure 7-3 Zero Page Addressing.

Since all of the addresses in the zero page are less than \$0100 (such as \$003F, for example) it follows that, if the computer knew enough to assume two leading hexadecimal zeroes, a zero page address could be represented in only one byte, saving both space and time. But if absolute addressing is used, the processor has to assume that two bytes follow an instruction to represent the operand, regardless of whether the high-order byte is zero or not.

This concept of expressing a zero page address with a single-byte operand was implemented on the 6502 and 65C02 by reserving separate opcodes for the various instructions using zero page addressing. Since an instruction's opcode for using zero page addressing is unique (as opcodes are for all of the different modes of a given instruction), the processor will fetch only one operand byte from the code stream, using it in effect as a displacement from a known base (\$0000, in the case of the 6502 and 65C02). Since only one byte need be fetched from the instruction stream to determine the effective address, the execution time is faster by one cycle. The result is a form of addressing that is shorter, both in memory use and execution time, than regular sixteen-bit absolute addressing.

Clearly, locating your most often accessed variables in zero page memory results in considerably shorter code and faster execution time.

The limitation of having this special area of memory available to the zero page addressing mode instructions is that there are only 256 bytes of memory available for use in connection with it. That is, there are only 256 zero page addresses. Resident system programs, such as operating systems and language interpreters, typically grab large chunks of page zero for their own variable space; applications programmers must carefully step around the operating system's variables, limiting assignment of their own program's zero page variables to some fraction of the zero page.

This problem is overcome on the 65816 by letting its direct page be set up anywhere within the first 64K of system memory (bank zero), under program control. No longer limited to page zero, it is referred to as **direct page addressing**. The result is, potentially, multiple areas of 256 (\$100) bytes each, which can be accessed one byte and one cycle cheaper than absolute memory. Setting the direct page anywhere is made possible by the 65816's **direct page register**, which serves as the base pointer for the direct page area of

## The Western Design Center

memory. Expressed in terms of the 65816's direct page concept, it can be said that on the 6502 (and 65C02), the direct page is fixed in memory to be the zero page.

So 6502 and 65C02 zero page addressing opcodes become direct page opcodes on the 65802 and 65816; and when they are executed, the "zero page address" - the single byte that the processor fetches immediately after the opcode fetch - becomes instead a **direct page offset**. This means that instead of simply pointing to a location in the range \$0000 to \$00FF as it would on the 6502 and 65C02, the direct page offset is added to the sixteen-bit value in the direct page register to form the **effective direct page address**, which can be anywhere in the range \$00;0000 to \$00;FFFF.

For purposes of this chapter, however, the discussion of the direct page addressing will be limited to the default case, where the value in the direct page register is zero, making it functionally identical to the 6502 and 65C02 zero page addressing mode. Since it requires the effective address to be computed, relocation of the direct page will be considered as a form of complex addressing, and will be covered in future chapters. While "direct page offset" is more correct, it is also more abstract; the term **direct page address** is most commonly used. However, it is essential to remember that it is, in fact, an offset relative to a previously established direct page value (again, as used in this chapter, \$0000).

An example of the use of direct page addressing to store a constant value to memory is as follows:

```
A9F0          LDA    #$FO
8512          STA    $12
```

This stores the one-byte value \$F0 at address \$0012. Note that the object code generated for the store requires only one byte for the opcode and one for operand.

```
A9F0          LDA    #$FO
8D0081        STA    $B100
```

This stores the same one-byte value at the address \$B100. In this case, the store requires one byte for the opcode and *two* bytes for the operand.

Notice how the assembler automatically assumes that if the value of the operand can be expressed in eight bits - if it is a value less than \$100, whether coded as \$34 or \$000034 - the address is a direct page address. It therefore generates the opcode for the direct page addressing form of the instruction, and puts only a one-byte operand into the direct page address to store to is \$12. One result of the assembler's assumption that values less than \$100 are direct page offsets is that physical addresses in the range \$xx:0000 to \$xxx:00FF cannot be referenced normally when either the bank (the "xx") register is other than zero or the direct page register is set to other than \$0000. For example, assembler syntax like:

```
A4FO          LDY    $FO
```

or

```
A4FO          LDY    $00FO
```

is direct page syntax. It will not access absolute address \$00F0 if the direct page register holds a value other than zero; nor will it access \$00F0 in another bank, even if the data bank register is set to the other bank. Both are evaluated to the same \$F0 offset in the direct page. Instead, to access physical address \$xx00F0, you must force absolute addressing by using the vertical bar or exclamation point in your assembler source line:

```
ACF000        LDY    !$FO          load Y absolute (not direct page ) from $00F0
```

## Indexing

An **array** is a table or list in memory of sequentially stored data items of the same type and size. Accessing any particular item of data in an array requires that you specify both location of the base of the array and the item number within the array. Either your program or the processor must translate the item number into the byte number within the array (they are the same if the items are bytes) and add it to the base location to find the address of the item to be accessed (*see* Figure 7.4).

## **The Western Design Center**

Sometimes an array might be a table of addresses, either of data to be accessed or of the locations of routines to be executed. In this case, the size of each item is two bytes; the first address is at locations zero and one within the array, the second at locations two and three, the third at locations four and five and so on. You must double the item number,



Indexing: Base plus Index

For example:

$$\begin{aligned} \text{Base} &= \$2000 \\ \text{Index Register X} &= \$03 \\ \hline \text{Effective Address} &= \$2003 \end{aligned}$$

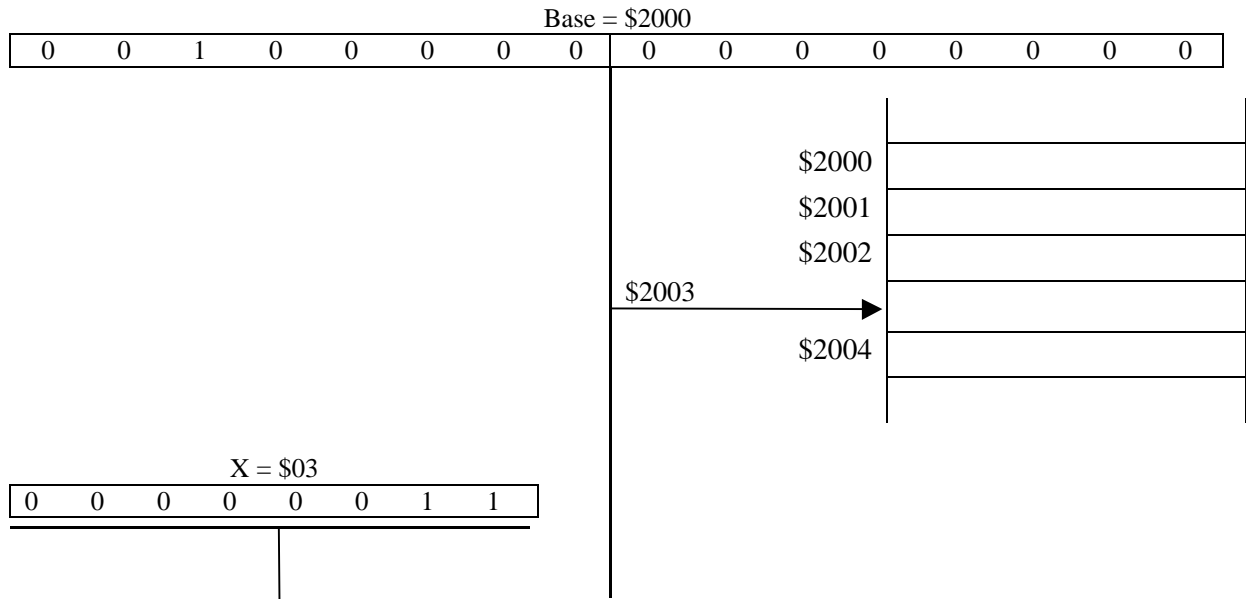

Figure 7-4 Indexing

resulting in the values 0, 2, 4, . . . from the array indicates 0, 1, 2, . . . and so on, to create an index into this array of two-byte data items.

The 65x processors provide a wide range of **indexing addressing modes** that provide automatic indexing capability. In all of them, a value in one of the two index registers specifies the unsigned (positive integer) index into the array, while the instruction's operand specifies either the base of the array or a pointer to an indirect address at which the base may be found. Each addressing mode has a special operand field syntax for specifying the addressing mode to the assembler. It selects the opcode that will correctly instruct the processor where to find both the base and index.

Some early processors (the 6800, for example) had only one index register; moving data from one array to another required saving off the first index and loading the second before accessing the second array, then incrementing the second index and saving it before reloading the first index to again access the first array. The 65x processors were designed with two index registers so data can be quickly moved from an array indexed by one to a second array indexed by the other.

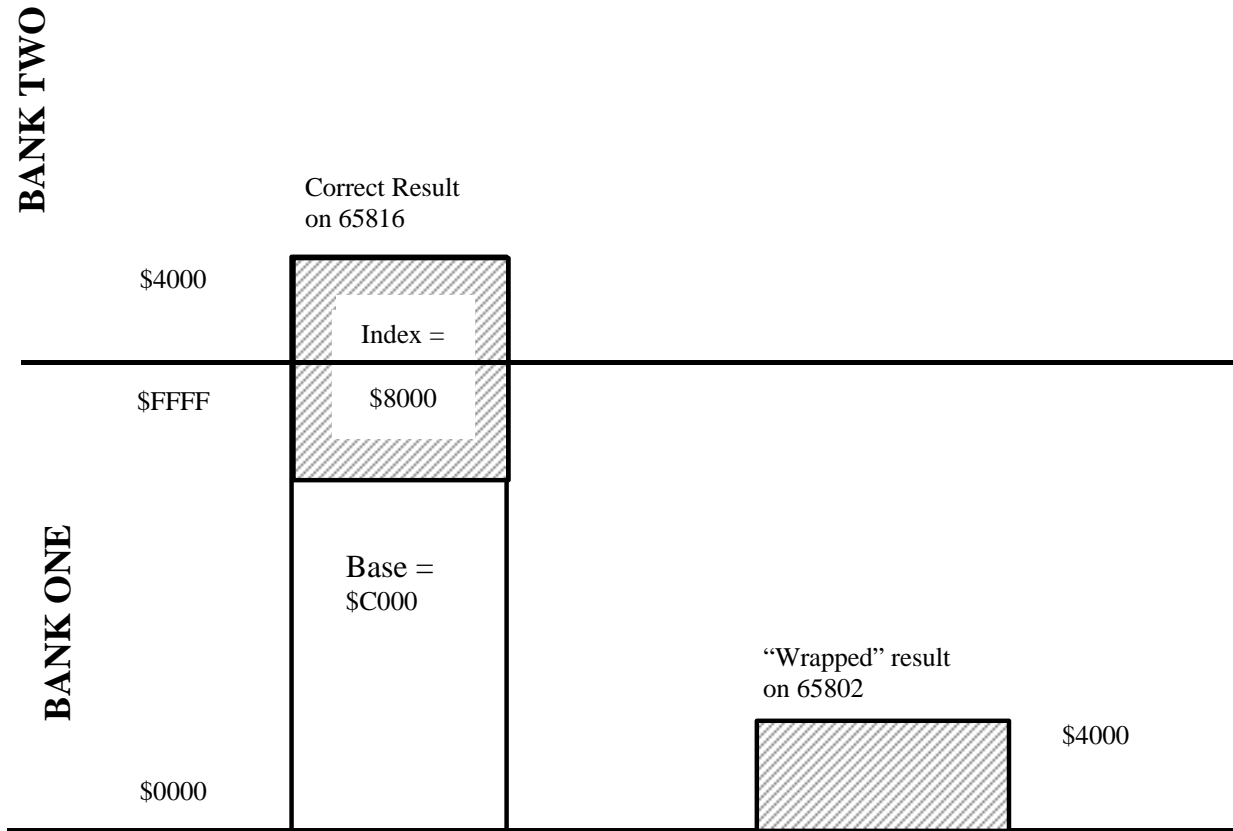

Figure 7-5 Indexing Beyond the End of the Bank

Often, the index registers are used simultaneously as indexes and as counters within loops in which consecutive memory locations are accessed.

The 65802 and 65816 index registers can optionally specify sixteen-bit offsets into an array, rather than eight-bit offsets, if the **x** index register select flag is clear when an indexed addressing mode is encountered. This lets simple arrays and other structured data elements be as large as 64K.

On the 6502, 65C02, and 65802, if an index plus its base would exceed \$FFFF, it wraps to continue from the beginning of the 64K bank zero; that is, when index is added to base, any carry out of the low-order sixteen bits lost. (See Figure 7.5.)

On the 65816, the same is true of direct page indexing: because the direct page is always located in bank zero, any time the direct page, plus an offset into the direct page, plus an index exceeds \$FFFF, the address wraps to remain in bank zero.

But as Figure 7.5 shows, whenever a 65816 base is specified by a 24-bit (long) address, or the base is specified by sixteen bits and assumes the data bank as its bank, then, if an index plus the low-order sixteen bits of its base exceeds \$FFFF, it will temporarily (just for the current instruction) increment the bank. The 65816 assumes that the array being accessed extends into the next bank.

### Absolute Indexed with X and Absolute Indexed with Y Addressing

Absolute addresses can be indexed with either the **X** (referred to as **Asolute,X** addressing) or the **Y** (referred to as **Absolute,Y** addressing) index register; but indexing with **X** is available to half again as many instructions as indexing with **Y**.

The base in these modes is specified by the operand, a sixteen-bit absolute address in the current data bank (Figure 7.6). The index is specified by the value in the **X** or **Y** register; the assembler picks the correct opcode on the basis of which index register the syntax specifies.

## The Western Design Center

In Fragment 7.4, the **X** register is used to load the accumulator from \$2200 plus 5, or \$2205. If run on the 65816 in native mode, then if the accumulator is set to sixteen-bit mode, two bytes will be loaded from \$2205 and \$2206 in the current data bank.

0000	A20500	LDX	#5	load an index value of five
0003	BD0022	LDA	\$2200,X	load the accumulator from \$2205

### Fragment 7.4

If the 65816 is in native mode and the index registers are set to sixteen-bit mode, indexes greater than \$FF can be used, as Fragment 7.5 illustrates.

0000	A00501	LDY	#\$105	load an index value of \$105
0003	B90022	LDA	\$2200,Y	load the accumulator from \$2305

### Fragment 7.5

If the index register plus the constant base exceeds \$FFFF, the result will continue beyond the end of the current 64K data bank into the next bank (the bank byte of the 24-bit address is temporarily incremented by one). So an array of any length (up to 64K bytes) can be started at any location and absolute indexed addressing will correctly index into the array, even across a bank boundary. 65802 arrays, however, wrap at the 64K boundary, since effectively there is only the single 64K bank zero.

Loading the index register with an immediate constant, as in the previous two examples, is of limited use: if, when writing a program, you know that you want the accumulator from \$2305, you will generate far fewer bytes by using absolute addressing:

```
AD0523    LDA    $2305    load the accumulator from $2305
```

The usefulness of indexed addressing becomes clear when you don't know, as you write a program, what the index into the array will be. Perhaps the program will select among indexes, or calculate one, or retrieve it from a variable, as in Fragment 7.6.

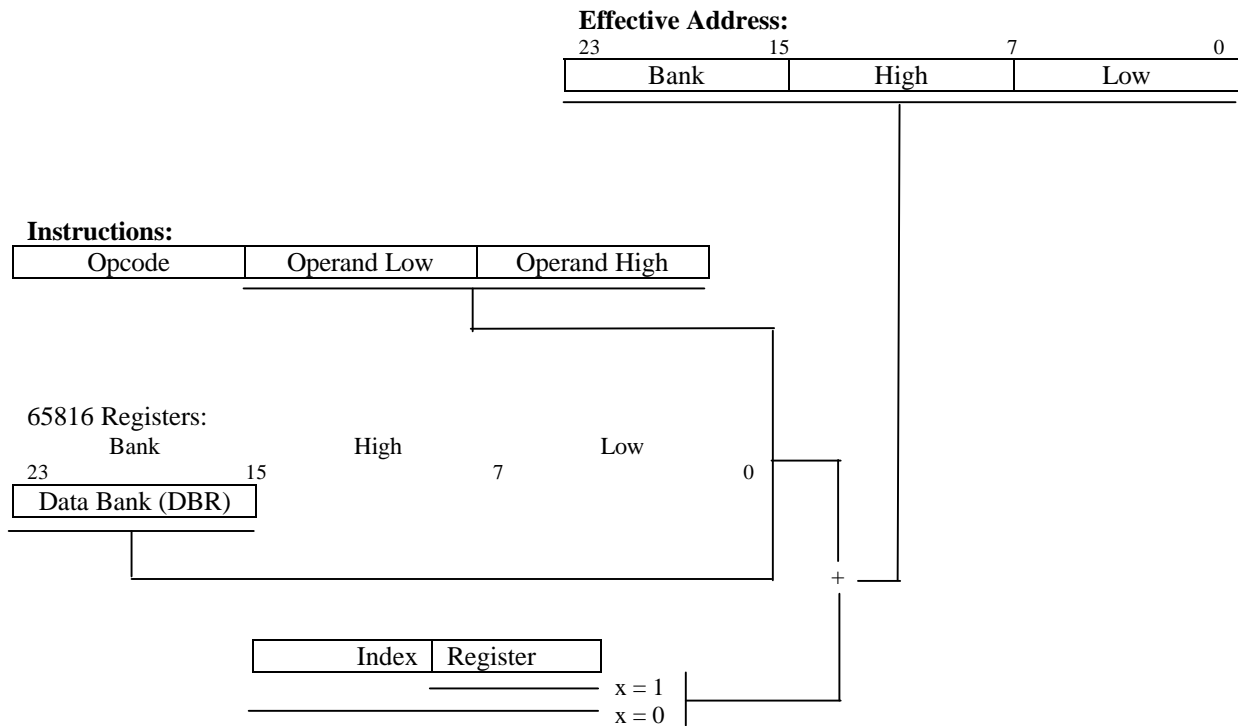

Figure 7-6 Absolute Indexing with a Generic Index Register

0000	AE0600	LDX	INDEX	get previously calculated index from memory
0003	BD0022	LDA	\$2200,X	load the accumulator from the array, X
0006	.	.	.	.
0006	.	.	.	.
0006	.	.	.	.
0006	0000	INDEX	DS	2

**Fragment 7.6.**

It can be useful to be able to put the base of an array into the index register and let it vary, while keeping the index into the array constant. This is seldom possible with the eight bits of the 6502's and 65C02's index registers, since they limit the base addresses they can hold to the zero page, but it is a useful capability of the 65802 and 65816.

For example, suppose, as in Fragment 7.7, you're dealing with dozens (or hundreds) of records in memory. You need to be able to update the fifth byte (which is a status field) of an arbitrary record. By loading the base address of the desired record into an index register, you can use a constant to access the status field. The index into the array, five, is fixed; the array base varies.

Because the index is less than \$100, the assembler would normally generate direct page indexing. To force the assembler to generate absolute indexing, not direct page indexing, you must use the vertical bar (or exclamation point) in front of the five, as Fragment 7.7 shows. That way, the five is generated as the double-byte operand \$0005, an absolute address to which the address in the index register is added to form the absolute effective address.

## The Western Design Center

0000		STATUS	GEQU	5	
0000		OK	GEQU	1	
0000		BAD	GEQU	0	
0000					
0000	18		CLC		
0001	FB		XCE		
0002					
0002	C210		REP	#\$10	set index registers to 16 bits
0004			LONGI	ON	
0004					
0004	E220		SEP	#\$20	
0006			LONGA	OFF	
0006					
0006	AE0E00		LDX	REC	get location of record to update
0006	AE0E00		LDX	#OK	load A with ok status token
0009	A901		LDA	!STATUS,X	store to status field
000B	9D0500		STA		force absolute,X addressing
000E		;			
000E			.		
000E			.		
000E			.		
000E	0030	REC	DC	a'\$3000'	loc of 1 <sup>st</sup> record (in data bank)

**Fragment 7.7**

Had the **Y** index register been used instead of the **X** in Fragment 7.7, the vertical bar would have been acceptable but not necessary; direct page, **Y** addressing, as you will learn in the next section, can only be used with the **LDX** and **STX** instructions, so the assembler would have been forced to use absolute,**Y** addressing regardless.

Both absolute,**X** and absolute,**Y** can be used by what are called the eight Group I instructions, the memory-to-accumulator instructions which can use more addressing modes than any others: **LDA**, **STA**, **ADC**, **SBC**, **CMP**, **AND**, **ORA**, and **EOR**. In addition, absolute,**X** can be used for shifting data in memory, incrementing and decrementing data in memory, loading the **Y** register, and for other instructions; but absolute,**Y** has only one other use – to load the **X** register.

### Direct Page Indexed with **X** and Direct Page Indexed with **Y** Addressing

Arrays based in the direct page (the zero page on the 6502 and 65C02) can be indexed with either the **X** register (called **Direct Page,X** addressing) or the **Y** register (called **Direct Page,Y** addressing). However, direct page,**Y** addressing is available only for the purpose of loading and storing the **X** register, while direct page,**X** is full-featured.

As is standard with indexed addressing modes, the index, which is specified by the index register, is added to the array base specified by the operand. Unlike the absolute indexed modes, array always starts in the direct page. So the array base, a direct page offset, can be specified with a single byte. The sum of the base and the index, a direct page offset, must be added to the value in the direct page register to find its absolute address, as shown in Figure 7.7.

In Fragment 7.8, the accumulator is loaded from a direct page offset base of \$32 plus index of \$10, or an offset of \$42 from the direct page register's setting.

0000	A21000	LDX	#\$10		set up an index of \$10
0003	B532	LDA	\$32,X		load accumulator from dp:\$42

**Fragment 7.8**

Remember that the effective address is an offset of \$42 from the direct page register and is always in bank zero. It will correspond to an absolute address of \$0042 only when the direct page register is equal to zero

**The Western Design Center**

(the default here in this chapter). Chapter 11, which covers the complex addressing modes, details relocation of the direct page.

When the index registers are set to eight bits, you can code the index and the array base interchangeably – they are both the same size. So the index, if it is a constant, may be specified as the operand, with the array base in the index register. Using the last example, the \$10 in the index register could be the direct page base of the array; the operand, \$32, would then be the index into an array in the direct page which begins at the direct page offset \$10.

On the 6502 and 65C02, and in they 6502 emulation modes of the two sixteen-bit processors, indexing past the end of the direct page wraps to the beginning of the direct page, as Fragment 7.9 shows. The index and the direct page array base are added, but only the low eight bits of the sum specify the direct page offset of the effective address. So in Fragment 7.9, while the base of \$32 plus the index of \$F0 equals \$122, only the \$22 is kept, and the accumulator is loaded from dp:\$22.

A2F0	LDX	#\$F0	set up an index of \$F0
B532	LDA	\$32,X	load accumulator from dp:\$22

**Fragment 7.9**

In 65802 and 65816 native mode, however, indexes can be sixteen bits, so direct page indexing was freed of the restriction that the effective address be within the direct page. Arrays always start in the direct page, but indexing past the end of the direct page extends on through bank zero, except that it wraps when the result is greater than \$FFFF to remain in bank zero (unlike absolute indexing, which temporarily allows access into the next higher bank).

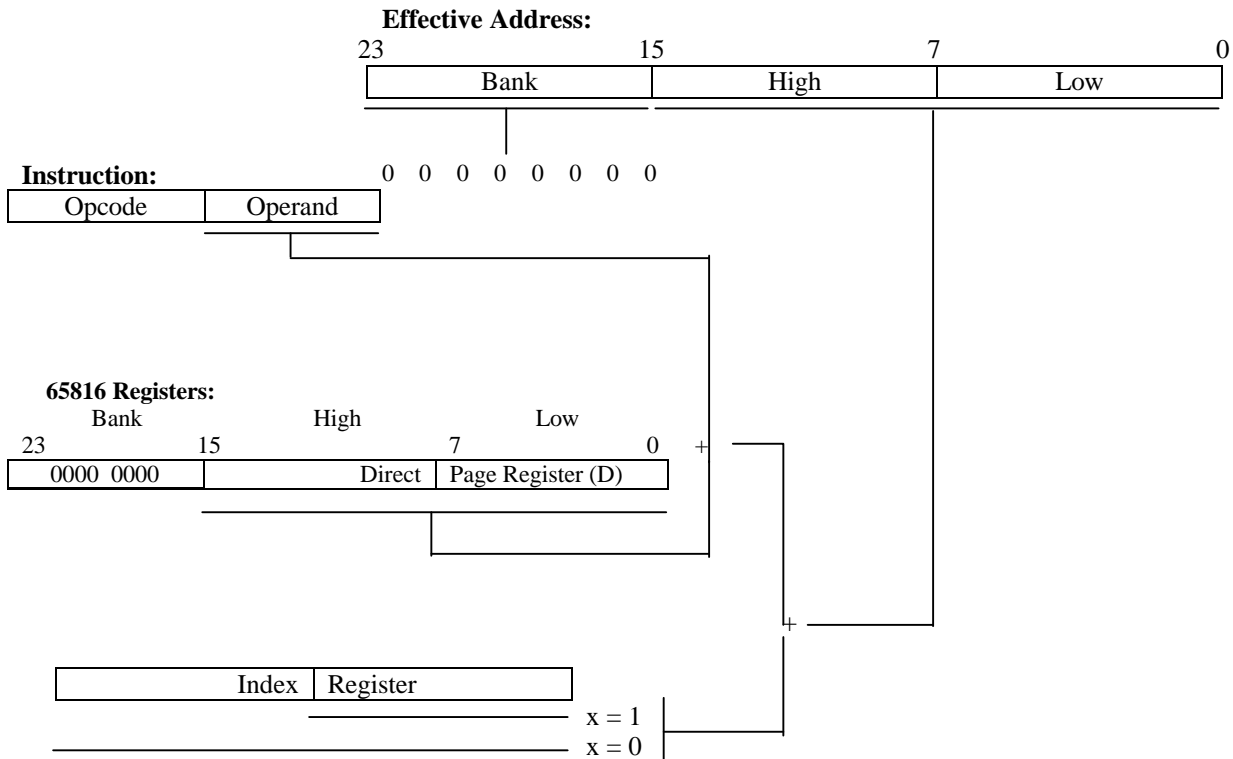

**Figure 7-7 Direct Page Indexing with a Generic Index Register**

In Fragment 7.10, the accumulator is loaded from the value in the direct page register plus the direct page base of \$12 plus index of \$FFF0, or dp:\$0002. Note this is in bank zero, not bank one.

## The Western Design Center

0000	C230	REP	#\$30	set index and accumulator 16-bit modes
0002		LONGA	ON	
0002		LONGI	ON	
0002				
0002	A2F0FF	LDX	#\$FFF0	
0005	B512	LDA	\$12,X	load accum from \$0002

### Fragment 7.10

If the index registers are set to sixteen bits and the array indexes you need to use are all known constants less than \$100, then you can use direct page indexing to access arrays beginning, not just in the direct page, but anywhere in bank zero memory: load the index register with the sixteen-bit base of the array and specify the index into the array as the operand constant. This technique would generally only be useful if the direct page register has its default value of zero.

## Accumulator Addressing

Accumulator addressing is only available for the read-modify-write instructions such as shifts and rotates. The instructions themselves will be explained in subsequent chapters, and use of accumulator addressing with them will be reviewed in detail.

As a simple addressing mode, accumulator addressing is included in this chapter for the sake of completeness even though the instructions which use it have not yet been introduced.

Generally, most operations take place upon two operands, one of which is stored in the accumulator, the other in memory, with the result being stored in the accumulator. Read-modify-write instructions, such as the shifts and rotates, are “unary” operations; that is, they have only a single operand, which in the case of accumulator addressing, is located in the accumulator. There is no reference to external memory in the accumulator addressing modes. As usual, the result is stored in the accumulator.

The syntax for accumulator addressing, using the **ASL** (arithmetic shift left) instruction as an example, is:

OA                      ASL                      A

## Implied Addressing

In implied addressing, the operand of the instruction is implicit in the operation code itself; when the operand is a register, it is specified in the opcode’s mnemonic. Implied operand instructions are therefore single-byte instructions consisting of opcode only, unlike instructions that reference external memory and as a result must have operands in subsequent bytes of the instruction.

You have already encountered implied addressing in the previous chapter in the form of the register transfer instructions and exchanges. Since there are a small number of registers, it is possible to dedicate an opcode to each specific registers transfer operation. Other instructions that use implied addressing are the register increments and decrements.

As one-byte instructions, there is no assembler operand field to be coded: You simply code the assembler mnemonic for the given instruction, as below:

7B	TDC	transfer direct page register to double accumulator
AA	TAX	transfer A to X
9B	TXY	transfer X to Y

## Stack

Stack addressing references the memory location pointed to by the stack register. Typical use of the stack addressing mode is via the push and pull instructions, which add or remove data to or from the stack area of memory and which automatically decrement or increment the stack pointer. Examples of the use of push and pull instructions were given in the previous chapter.

Additionally, the stack is used by the jump to subroutine, return from subroutine, interrupt, and return from interrupt instructions to automatically store and retrieve addresses and in some cases also the status register. This form of stack addressing will be covered in Chapter 12, Subroutines, and Chapter 13, System Control.

The assembler syntax of the push and pull instructions is similar to that of implied instructions; no operand field is coded, since the operation will always access memory at the stack pointer location.

## Direct Page Indirect Addressing

**Direct page indirect** addressing, or, as it is known on the 65C02, **zero page indirect**, is unavailable on the 6502; it was first introduced on the 65C02.

Indirect addressing was designed for the 65C02 as a simplification of two often-used complex forms of addressing available on the 6502 known as zero page indirect indexed and zero page indexed indirect addressing (these forms of addressing on the 65816 are of course *direct page* indirect indexed or indexed indirect addressing; they are explained in Chapter 11, Complex Addressing Modes). It was found that programmers were tolerating the overhead inherent in these two complex addressing modes to simulate indirection.

The concept of simple indirect addressing lies on the borderline between the simple and complex addressing modes. An understanding of it forms the basis for understanding several of the more complex indexed modes which use indirection as well.

An **indirect address** is an address stored in memory which points to the data to be accessed; it is located by means of the operand, an address which points to the indirect address, as shown in Figure 7.8. Except in the case of indirect jump instructions, explained in Chapter 8, Flow of Control, this pointer is always a direct page address.

The use of indirect addresses brings great flexibility to the addressing options available to you. There is, however, a penalty in execution speed, imposed by the fact that, in addition to the operand fetch from the code stream, the actual effective address must also be fetched from memory before the data itself can be accessed. For this reason, direct page addresses are used as the pointers to the indirect addresses since, as you will remember from the discussion of direct page addressing, the direct page offset itself can be determined with only a single memory fetch.

The syntax for indirect addressing is to enclose in parentheses, as the operand, the direct page pointer to the indirect address.

```
B280                LDA    ($80)
```

This means, as figure 7.8 illustrates, “go to the direct page address \$80 and fetch the absolute (sixteen-bit) address stored there, and then load the accumulator with the data at the address.” The low-order byte of the indirect address is stored at dp:\$80, the high-order byte at dp:\$81 – typical 65x low/high fashion. Remember, in the default case where **DP** equals \$0000, the direct page address equals the zero page address, namely \$00:0080.

As explained above, the indirect address stored at the direct page location (point to by the instruction operand) is a sixteen-bit address.



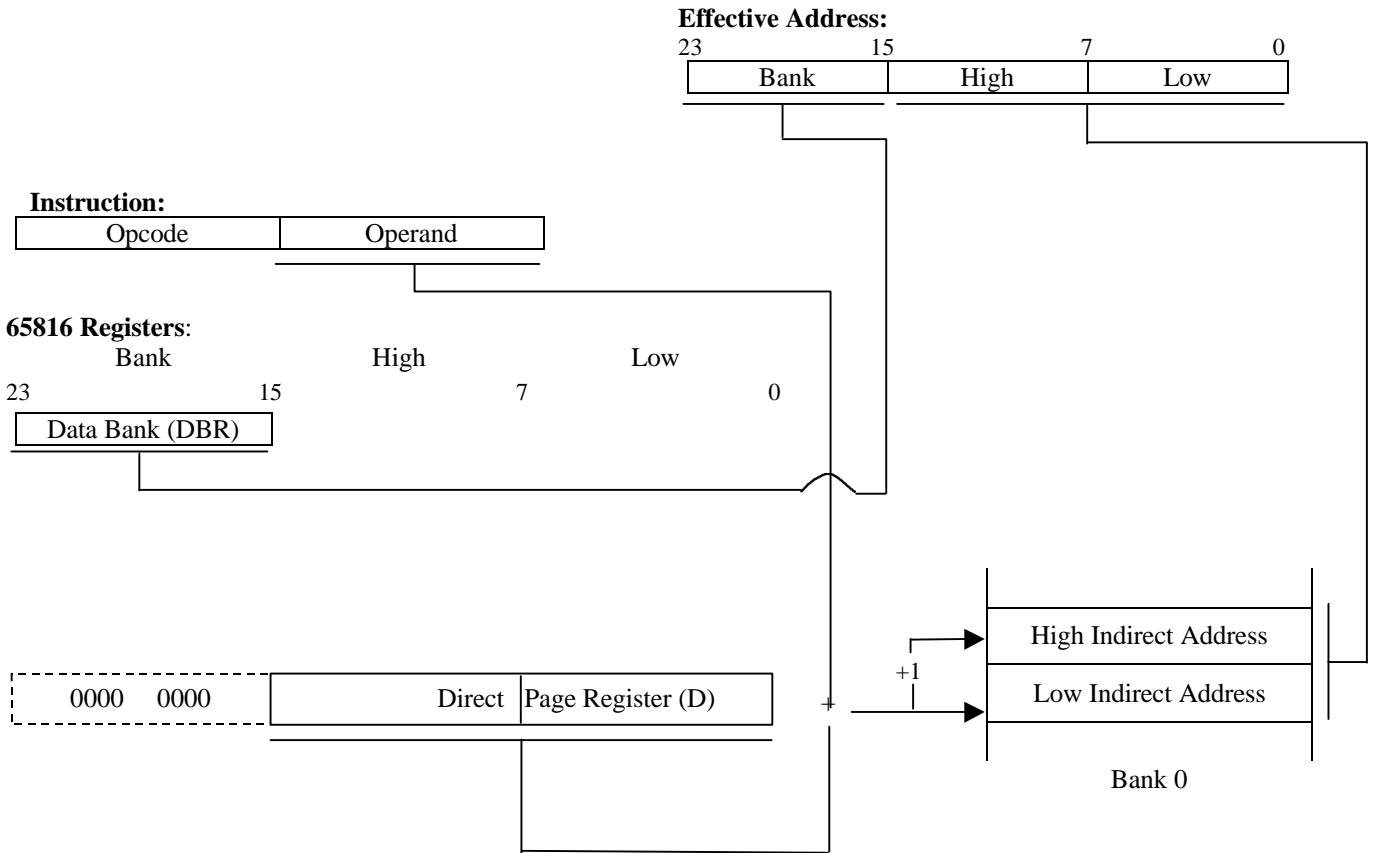

**Figure 7-8 Direct Page Indirect Addressing**

The general rule for the 65816 is that when an addressing mode only specifies sixteen bits of the address, then the bank byte (bits 16-23) of the address is provided by the data bank register. This rule applies here; but you must first note that the direct page offset which *points* to the indirect address is itself always located in bank zero because the direct page itself is *always* located in bank zero. The examples, however, were simplified to assume both the data bank and the direct page register to be zero.

The use of indirect addressing allows an address that is referenced numerous times throughout a routine and is subject to modification – for example, a pointer to a data region – to be modified in only one location and yet alter the effective address of many instructions.

In Listing 7.1, the data \$1234 is moved from location **VAR1** to **VAR2**. Note that the load and store instructions had the same operand: the symbol **DPA**, which had been given a value of \$80. The indirect address stored at that location was different in each case, however, resulting in the data being copied from one location to another. While this example in itself is an inefficient way to move a double-byte word to another location, it does illustrate the basic method of indirect addressing, which will become quite useful as looping and counting instructions are added to your working set of 65x instructions.

### Absolute Long Addressing

This is the first of the simple addressing modes that are available only on the 65816 and 65802 processors.

Absolute long addressing is an extension of (sixteen-bit) absolute addressing – that is, addressing at a known location. Remember that on the 6502 and 65C02, address space is limited to 64K, and any location within the entire memory range can be specified with a sixteen-bit address. This is not the case with the 65816, which can address up to sixteen megabytes of memory. Thus 24 bits are required to specify a given memory location.

In general, there are two ways by which a 24-bit data address is generated. In the case of sixteen-bit absolute addressing, a 64K memory context is defined by the value of the data bank register; the bank byte of

## The Western Design Center

the 24-bit address is derived directly from that register via simple concatenation (connecting together) of the data bank value and the sixteen-bit address. The alternative method is to specify a complete 24-bit effective address for a given instruction. The absolute long address-bit effective address for a given instruction. The absolute long addressing mode is one of the means for doing this.

As the name should imply, this addressing mode specifies a known, fixed location within the sixteen-megabyte addressing space of the 65816, just as sixteen-bit absolute addressing specifies a known, fixed location within either the 64K space of the 6502, 65C02, or 65802, or else the 64K data space determined by the 65816's data bank register. Just as the sixteen-bit absolute addressing operations are three-byte instructions, consisting of opcode, address low, and address high, the instructions that use the 24-bit absolute long addressing modes are four-byte instructions, comprised of opcode, low byte of address, high byte of address, and bank byte of address, as shown in Figure 7.9. The value in bits 8-15 of the effective address is described as the high byte, and 16-23 as the bank byte, because this most clearly reflects both the parallels with the 6502 and 65C02 and bank-oriented memory segmentation of the 65816 architecture.

## The Western Design Center

0001	0000			KEEP	KL.7.1	
0002	0000					
0003	0000			65816	ON	
0004	0000					
0005	0000		MAIN	START		
0006	0000					
0007	0000		DPA	EQU	\$80	give memory cell at \$80 a label
0008	0000					
0009	0000		;			switch from 6502 emulation to native mode
0010	0000					
0011	0000	18		CLC		clear carry flag
0012	0001	FB		XCE		exchange carry with e bit (clear e bit)
0013	0002					
0014	0002	C230		REP	#\$30	set 16-bit registers
0015	0004			LONGA	ON	
0016	0004			LONGI	ON	
0017	0004					
0018	0004	A01500		LDY	#VAR1	get the address where \$1234 is stored
0019	0007	8480		STY	DPA	and store it as an indirect address at \$80
0020	0009	8280		LDA	(DPA)	now load \$1234 indirectly
0021	000B	A01700		LDY	#VAR2	change the indirect address DPA
0022	000E	8480		STY	DPA	to point to VAR2
0023	0010	9280		STA	(DPA)	and store \$1234 by overwriting the \$0000 there
0024	0012					
0025	0012		;			return to 6502 emulation mode
0026	0012					
0027	0012	38		SEC		set carry flag
0028	0013	FB		XCE		exchange carry with e bit (set e bit)
0029	0014					
0030	0014	60		RTS		
0031	0015					
0032	0015	3412	VAR1	DC	A'\$1234'	
0033	0017	0000	VAR2	DC	A'000'	
0034	0019					
0035	0019			END		

**Listing 7.1**

When absolute long addressing is used, the bank address in the operand of the instruction temporarily overrides the value in the data bank register *for the duration of a single instruction*. Thus, it is possible to directly address any memory location within the entire sixteen-megabyte address space.

You will likely find, however, that this form of addressing is one of the less frequently used. There are two reasons for this: first, it is more efficient to use the shorter sixteen-bit addressing modes, provided that the data bank register has been appropriately set; second, it is generally undesirable to hard code fixed 24-bit addresses into an application, as this tends to make the application dependent on being run in a fixed location within a fixed bank. (An exception to this is the case where the address referenced is an I/O location, which is fixed by the given system hardware configuration.)

The 65x processors, in general, do not lend themselves to writing entirely position-independent code, although the 65816 certainly eases this task compared to the 6502 and 65C02. There is, however, no reason why code should not be written on the 65816 and 65802 to be **bank-independent** – that is, capable of being executed from an arbitrary memory bank. But using absolute long addressing will tend to make this difficult if not impossible.

If you are using a 65802 in an existing system, it is important to note that although the address space of the 65802 is limited to 64K at the hardware level, internally the processor still works with 24-bit addresses. One thing this means is that it is legal to use the long addressing modes such as absolute long. But using them is futile, even wasteful: an extra address byte is required for the bank, but the bank address generated is ignored. There are cases where use of forms of long addressing other than absolute long should be used if you are targeting your code for both the 65802 and the 65816. But generally there is little reason to use the absolute

## The Western Design Center

long addressing mode on the 65802, except perhaps for fine-tuning a timing loop (the absolute long addressing mode requires an extra cycle to execute in order to fetch the bank address in the fourth byte of the instruction).

The assembler syntax to indicate the absolute long addressing mode is simply to code a value in the operand field greater than \$FFFF. To force long addressing for bank zero addresses (\$00:0000 to \$00:FFFF), use the greater sign (>) as a prefix to the operand (similar to the use of the vertical bar to force sixteen-bit absolute addressing) as shown in Fragment 7.11.

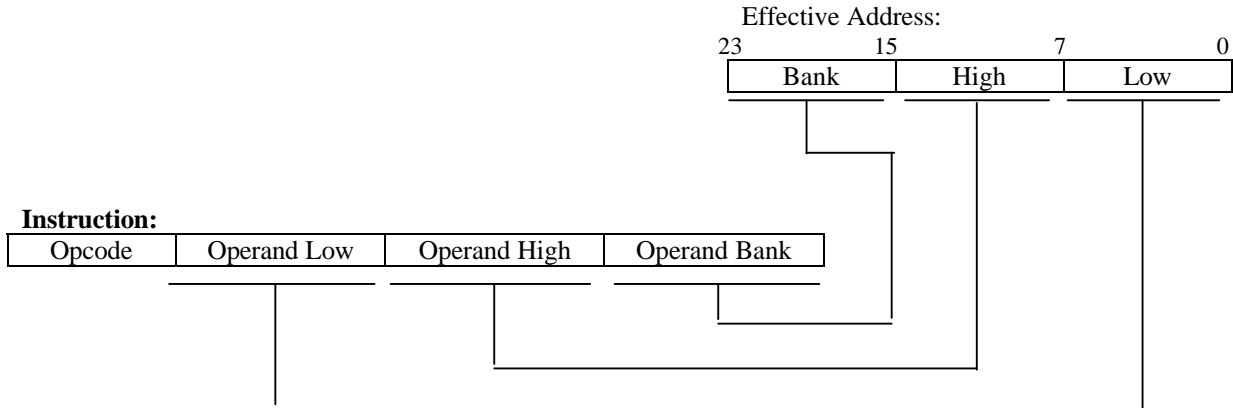

**Figure 7-9 Absolute Long Addressing**

Note that the first **STA** instruction in Fragment 7.11 generates a four-byte instruction to store the accumulator to a bank zero address, while the second **STA** instruction generates a three-byte instruction to store the accumulator to the same sixteen-bit displacement but within bank two, the current data bank. Also note that for both the load and the first store instructions, absolute long addressing causes the current data bank register, which is set to two, to be overridden.

0000	E220	SEP	#\$20	set 8 bit accumulator
0002		LONGA	OFF	
0002				
0002	A902	LDA	#\$02	set data bank
0004	48	PHA		to bank two
0005	AB	PLB		
0006				
0006	AF9DA303	LDA	\$03A39D	absolute long at \$03:A39D
000A	8F7F2E00	STA	>\$2E7F	store data to \$00:2E7F
000E	8D7F2E	STA	\$2E7F	store data to \$02:2E7F

**Fragment 7.11**

## Absolute Long Indexed with X Addressing

**Absolute long indexed with X**, or **absolute long indexed**, uses the X register for its index, and an absolute long address as its base. It lets you index into an array located in a bank other than the data bank.

Instructions using absolute long indexed addressing are four bytes in length, since three bytes are needed to express 24-bit absolute-long operands. The bank byte, being the highest byte in the operand, is the fourth byte of the instruction. The contents of the **X** index register are added to the absolute-long operand to form the 24-bit effective address at which data will be accessed.

For example, Fragment 7.12 gets a character from a text buffer starting at \$3000 in bank zero and stores it into buffers starting at \$1000 in bank two and at \$E000 in bank three. Because the character to be loaded is in bank zero, its long address is expressed in sixteen bits. You must preface a reference to it with the greater-than sign to override the assembler assumption that a sixteen-bit operand is in the data bank, and force the assembler to instead use long addressing. The next instruction stores to the data bank, requiring only absolute indexing; the assembler assumes simple sixteen-bit operands are located in the data bank. Finally, storing into bank three

## The Western Design Center

requires no special specification: since \$03E000 cannot be expressed in sixteen bits, long addressing is assumed.

0000	E220	SEP	#\$20	set accumulator to 8 bits
0002		LONGA	OFF	
0002	C210	REP	#\$10	set indexes to 16 bits
0004		LONGI	ON	
0004				
0004	A902	LDA	#2	set the data bank to bank 2
0006	AB48	PHA		
0007	AB	PLB		
0008				
0008	AE0080	LDX	BUFIDX	get 16 bit buffer index
000B	BF003000	LDA	>\$3000,X	force long indexed abbr:bank0
000F	9D0010	STA	\$1000,X	store into data bank (bank 2)
0012	9F00E003	STA	\$03E000,X	store into bank 3

Fragment 7.12

### Direct Page Indirect Long

Direct page indirect long is another case of long (24-bit) addressing, where the effective address generated temporarily overrides the current value in the data bank register. Unlike the previous two long addressing modes, however, the 24-bit address is not contained in the operand itself. The instruction is two bytes long, much like regular direct page indirect addressing. The operand of the instruction is, like its non-long counterpart, a direct page offset acting as an indirect pointer; the difference in this case is that rather than pointing to a sixteen-bit address in the data bank, it points to a 24-bit address. If, for example, the direct page address is \$80, as in Figure 7.10, the processor will fetch the low byte of the effective address from dp:\$80, the high byte from dp:\$81, and the bank byte from dp:\$82. The bank byte temporarily overrides the value in the data bank register.

Fragment 7.13 shows the use of both direct page indirect addressing and direct page indirect long, using the latter to access the data as set up in Figure 7.10. The syntax for indirect long addressing is similar to that for direct page indirect, except left and right square brackets rather than parentheses enclose the direct page address to indicate the indirect address is long.

In this example, a sixteen-bit accumulator size is used with eight-bit index registers. The simultaneous availability of both an eight-bit and a sixteen-bit register in this mode simplifies the manipulation of long addresses. First, a value of \$04 is loaded into the eight-bit Y register using immediate addressing. Since the **LONGI OFF** directive has been coded, the assembler automatically generates an eight-bit operand for this instruction. This is pushed onto the stack, and then pulled into the bank register. Next, Y is loaded with #\$02, the bank component of the indirect address, which is stored to dp:\$82. The sixteen-bit accumulator is then used to load an immediate \$2000 (high/low of the indirect and the indirect long addresses), which is stored at dp:\$80. This results in the following values in memory: at dp:\$80 is \$00, at dp:\$81 is \$20, and at dp:\$82 is \$02. The data bank register contains the indirect address \$2000, while the memory at locations dp:\$80.81 contains the indirect address \$2000, while the memory at locations dp:\$80.82 contains the indirect long address \$02:2000. The load indirect instruction uses the data bank register to form the bank address, and so loads double-byte data from \$04:2000. The store indirect long stores the double-byte data at \$02:2000. The overlapping of the low and high bytes of the indirect address in location dp:\$80 and dp:\$81 highlights the difference in the source of the bank byte using the two addressing modes.

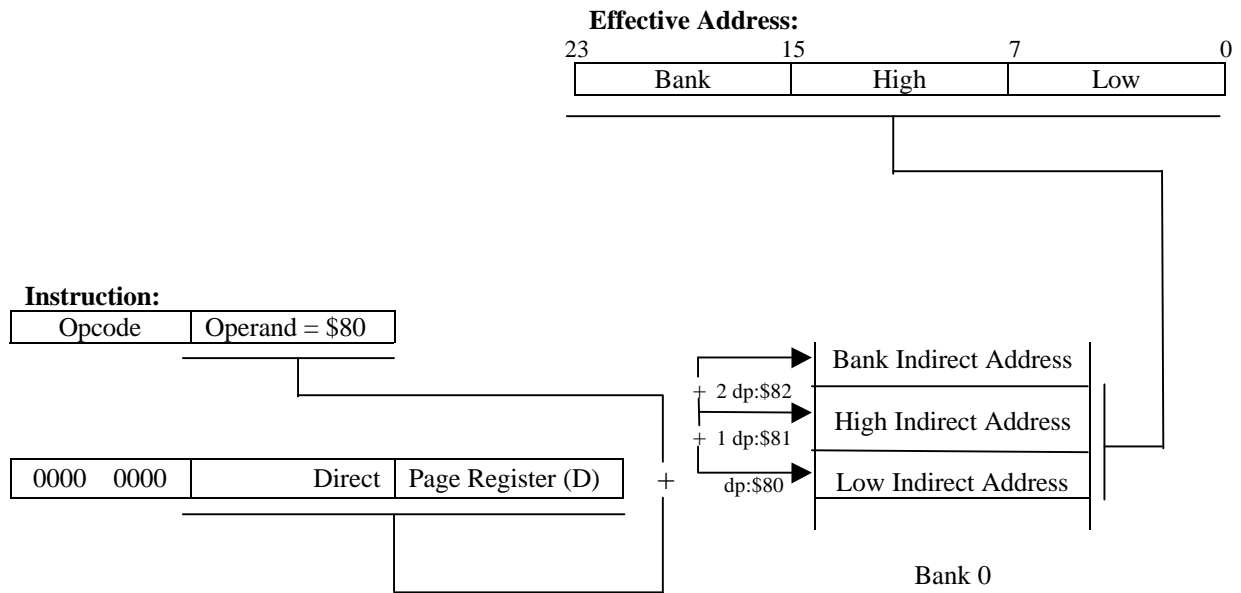

Figure 7-10 Direct Page Indirect Long Addressing

0000	C220	REP	#\$20	set accum/memory size to 16 bits
0002		LONGA	ON	
0002				
0002	E210	SEP	#\$10	set index size to eight bits
0004		LONGI	OFF	
0004				
0004	A004	LDY	#\$04	set data bank
0006	5A	PHY		to bank 4
0007	AB	PLB		
0008				
0008	A002	LDA	#\$02	bank of indirect address
000A	8482	STA	\$82	
000C				
000C	A90020	LDA	#\$2000	high/low of indirect address
000F	8580	STA	\$80	
0011				
0011	B280	LDA	(\$80)	load indirect from \$04:2000
0013	8780	STA	[\$80]	store indirect long to \$02:2000

Fragment 7.13

## Block Move

Block move addressing is a dedicated addressing mode, available only for two instructions, **MVN** and **MVP**, which have no other addressing modes available to them. These operations were explained in the previous chapter.

# 8) Chapter Eight

## The Flow of Control

**Flow of control** refers to the way in which a processor, as it executes a program, makes its way through the various sections of code. Chapter 1 discussed four basic types of execution: straight-line, selection between paths, looping, and subroutines. This chapter deals with those instructions that cause the processor to jump or branch to other areas of code, rather than continuing the default straight-line flow of execution. Such instructions are essential to selection and looping.

The jump and branch instructions alter the default flow of control by causing the **program counter** to be loaded with an entirely new value. In sequential execution, on the other hand, the program counter is incremented as each byte from the code stream – opcode or operand – is fetched.

The 65x processors have a variety of branch and jump instructions, as shown in Table 8.1. Of these, when coding in the larger-than-64K environment of the 65816, only the three jumping-long instructions (jump indirect long, jump absolute long, and jump subroutine long) and the return from subroutine long instruction are capable of changing the program bank register – that is, of jumping to a segment of code in another bank. All of the other branch or jump instructions simply transfer within the current bank. In fact, the interrupt instructions (break, return from interrupt, and coprocessor instructions) are the only others which can change the program bank; there is no direct way to modify the program counter bank without at the same time modifying the program counter register because the program counter would still point to the next instruction in the old bank.

Mnemonic	Available on:			Description
	6502	65C02	65802/816	
BEQ	x	x	x	branch on condition instruction (eight)
JMP	x	x	x	jump absolute
JMP	x	x	x	jump indirect
JSR	x	x	x	jump subroutine absolute
RTS	x	x	x	return from subroutine
BRA		x	x	branch always (unconditional)
JMP		x	x	jump absolute indexed indirect
BRL			x	branch long always (unconditional, 64K range)
JSR			x	jump to subroutine absolute indexed indirect
JMP			x	jump indirect long (interbank)
JMP			x	jump absolute long (interbank)
JSL			x	jump subroutine long (interbank)
RTL			x	return from subroutine long (interbank)

**Table 8-1. Branch and Jump Instructions**

As you may have noticed, all of the flow-of-control instructions (except the return instructions) can be divided into two categories: jump-type instructions and branch-type instructions. This division is based on addressing modes: branch instructions use program counter relative addressing modes; jump instructions don't.

Jump instruction can be further split into two groups: those which transfer control to another section of code, irreversibly, and those which transfer control to a subroutine, a section of code which is meant to eventually return control to the original (calling) section of code, at the instruction following the jump-to-subroutine instruction.

## The Western Design Center

The jump instructions will be covered in this chapter first, then the branches; jump-to-subroutine instructions will be discussed in Chapter 12, which deals with subroutines.

### Jump Instructions

The jump instruction (**JMP**) can be used with any one of five different 65816 addressing modes (only two of these are available on the 6502, a third is available on the 65C02) to form an effective address; control then passes to that address when the processor loads the program counter with it. For example,

```
4C0020          JMP          $2000      jump absolute to the code at location $2000
```

uses absolute addressing, a mode available to all 65x processors, to pass control to the code located at \$2000 in the current program bank. (Notice that using absolute addressing to access data in the last chapter used the data bank in place of the program bank.)

In addition to absolute addressing, all of the 65x processors provide a jump instruction with absolute indirect addressing. While this form of indirect addressing is unique to the jump instruction, it is quite similar to the direct page indirect addressing mode described in Chapter 7. In this case, the sixteen-bit operand is the address of a double-byte variable located in bank zero containing the effective address; the effective address is loaded into the program counter. As with absolute addressing, the program bank remains unchanged (Figure 8.1).

For example, the jump instruction in Fragment 8.1 causes the processor to load the program counter with the value in the double-byte variable located at \$00:2000. Unlike direct page indirect addressing, the operand is an absolute address rather than a direct page offset. Furthermore, this form of absolute addressing is unusual in that it *always* references a location in bank zero, *not* the current data bank.

0000		LONGA	ON	
0000	C220	REP	#\$20	set 16-bit accumulator
0002	A93412	LDA	#\$1234	load sixteen-bit accumulator with \$1234
0005	8F002000	STA	>\$2000	store long to location \$00:2000
0009	6C0020	JMP	(\$2000)	jump to location \$1234 in program bank

#### Fragment 8.1

The 65C02 added the absolute indexed indirect addressing mode to those available to the jump instruction. This mode is discussed further in Chapter 12, The Complex Addressing Modes. Although its effective address calculation is not as simple as the jump absolute or jump absolute indirect, its result is the same: a transfer of control to a new location.

The 65802 and 65816 added long (24-bit) versions of the absolute and indirect addressing modes. The absolute long addressing mode has a three-byte operand; the first two bytes are loaded into the program counter as before, while the third byte is loaded into the program bank register, giving the jump instruction a full 24-bit absolute addressing mode. For example,

```
5C4423FF          JMP          $FF2344
```

causes the program counter to be loaded with \$2344 and the program bank counter with \$FF. Note that on that 65802, even though the bank address is effectively ignored; the jump is to the same location as the equivalent (sixteen-bit) absolute jump.



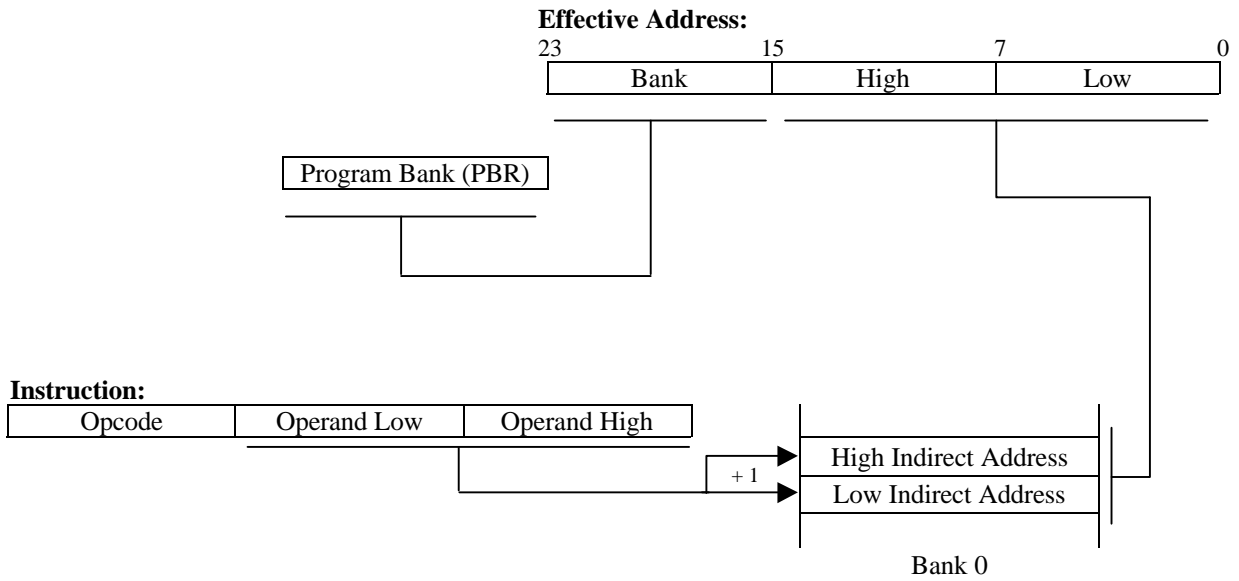

Figure 8-1 Jump's Absolute Indirect Addressing Mode

When the target of a long jump is in bank zero, say to \$00A030, then the assembler has a problem. It assumes a jump to any address between zero and \$FFFF (regardless of whether it's written as \$A030 or \$00A030) is a jump within the current program bank, not to another bank, so it will generate an absolute jump, not a long jump. There are two solutions. One is to use the greater-than sign (>) in front of the operand, which forces the assembler to override its assumptions and use long addressing:

```
5C30A000      JMP    >$A030      long jump from current program bank to $00:A030
```

The alternative is to use the **JML** alias, or alternate mnemonic, which also forces a jump to be long, even if the value of the operand is less than \$10000:

```
5C30A000      JML    $A030      jump from current bank to $00:A030
```

The final form of the jump instruction is a 24-bit (long) jump using absolute indirect addressing. In the instruction,

```
DC0020      JMP    [$2000]      jump to the 24-bit address stored at $00:2000
```

the operand is the bank zero double-byte address \$2000, which locates a *triple-byte* value; the program counter low is loaded with the byte at \$2000 and the program counter high with the byte at \$2001; the program bank register is loaded with the byte at \$2002. A standard assembler will allow the **JML** (jump long) alias here as well.

Notice that absolute indirect long jumps are differentiated from absolute indirect jumps within the same bank by using parentheses for absolute indirect jumps within the same bank by using parentheses for absolute direct and square brackets for absolute indirect long. In both cases the operand, an absolute address, points to a location in bank zero.

The jump instructions change no flags and affect no registers other than the program counter.

## Conditional Branching

While the jump instructions provide the tools for executing a program made up of disjointed code segments or for looping, they provide no way to conditionally break out of a loop or to select between paths. These are the jobs of the conditional branch instructions.

The jump instruction requires a minimum three bytes to transfer control anywhere in a 64K range. But selection between paths is needed so frequently and for the most part for short hops that using three bytes would tend to be unnecessarily costly in memory usage. To save memory, branches use an addressing mode called program counter relative, which requires just two bytes; the branch opcode is followed by a one-byte operand – a signed, two’s-complement offset from the current program location.

When a conditional branch instruction is encountered, the processor first tests the value of a status register flag for the condition specified by the branch opcode. If the branch condition is false, the processor ignores the branch instruction and goes on to fetch and execute the next instruction from the next sequential program location. If, on the other hand, the branch condition is true, then the processor transfers control to the effective address formed by adding the one-byte signed operand to the value currently in the program counter (Figure 8.2).

As Chapter 1 notes, positive numbers are indicated by a zero in the high bit (bit seven), negative numbers by a one in the high bit. Branching is limited by the signed one-byte operands to 127 bytes forward or 128 bytes backward, counting from the end of the instruction. Because a new value for the program counter must be calculated if the branch is taken, an extra execution cycle is required. Further, the 6502 and 65C02 (and 65802 and 65816 in emulation mode) require an additional cycle if the branch crosses a page boundary. The native mode 65802 and 65816 do not require the second additional cycle, because they use a sixteen-bit (rather than eight-bit) adder to make the calculation.

The program counter value to which the operand is added is *not* the address of the branch instruction but rather the address of the opcode *following* the branch instruction. Thus, measured from the branch opcode itself, branching is limited to 129 bytes forward and 126 bytes backward. A conditional branch instruction with an operand of zero will continue with the next instruction regardless of whether the condition tested is true or false. A branch with an operand of zero is thus a two-byte no-operation instruction, with a variable (by one cycle) execution time, depending on whether the branch is or isn’t taken.

The 65x processors have eight instructions which let your programs branch based on the settings of four of the condition code flag bits in the status register: the zero flag, the carry flag, the negative flag, and the overflow flag.

None of the conditional branch instructions change any of the flags, nor do they affect any registers other than the program counter, which they affect only if the condition being tested for is true. The most recent flag value always remains valid until the next flag-modifying instruction is executed.

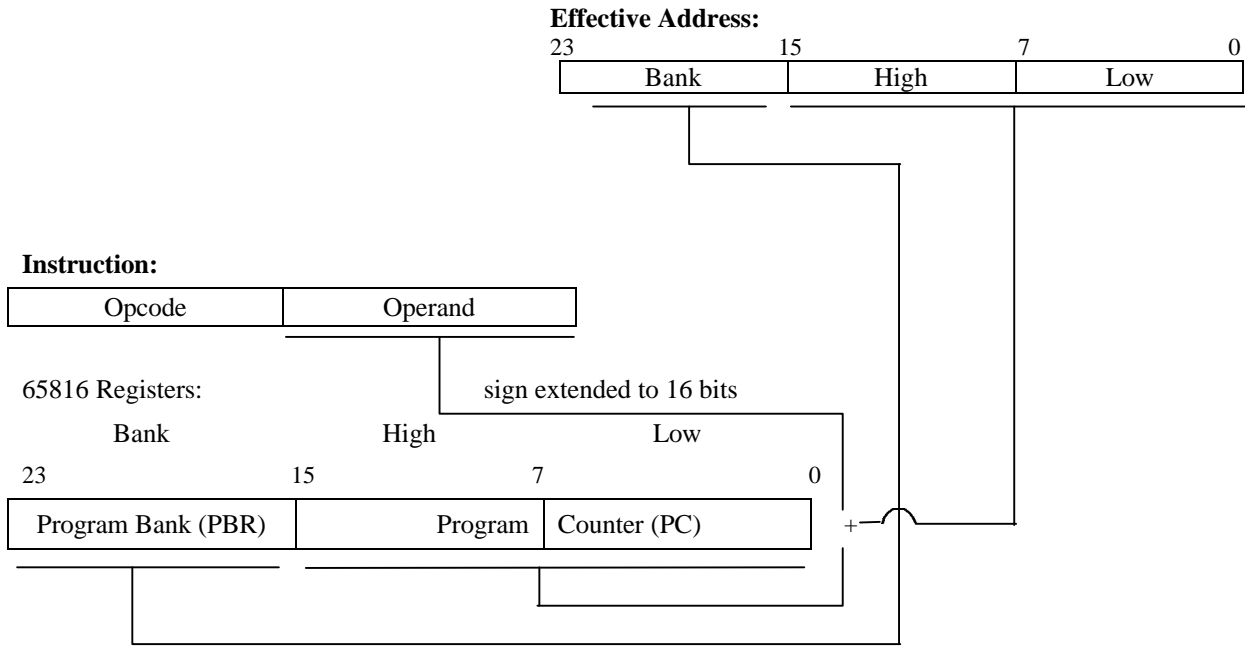

Figure 8-2. Relative Branch Calculation

**Branching Based on the Zero Flag**

The zero bit in the status register indicates whether or not the result of an arithmetic, logical, load, pull, or transfer operation is zero. A zero result causes the bit to be set; a non-zero result causes the bit to be reset.

The **BEQ** instruction is used to branch when a result is zero – that is, when the zero bit is set. Its mnemonic meaning, that of **branch if equal (to zero)**, describes what the processor does. Alternatively, it may be considered a mnemonic for **branch if (comparison) equal** because it is often used after two values are compared or subtracted; if the two values are equal, then the result of the comparison (subtraction) is zero (no difference), and the branch is taken.

The **BNE** instruction is used to branch when a result is not zero. Also, any non-zero value which is loaded into a register will clear the zero flag. It is a mnemonic for **branch if not equal**; it too is used to branch after a comparison or subtraction if the two values are not equal.

Zero is often used as a terminator, indicating the end list, or that a loop counter has counted down to the end of the loop. Fragment 8.2 is a short routine to search for the end of a linked list of records, and then insert a new element at the end. Each element in the list contains a pointer to the next element in the chain. The last element in the chain contains a zero in its link field, indicating that the end of the list has been reached.

## The Western Design Center

0000		;		traverse linked list searching for end of chain	
0000					
0000	AC0080		LDY	NEXTNODE	nextnode contains address of next
0003		;			data element to be inserted.
0003	A90080		LDA	#ROOT	ROOT contains the address of
0006		;			the link field of the first
0006		;			record in the chain.
0006	AA	LOOP	TAX		use fetched address to bet next link
0007	B500		LDA	0,x	
0009	D0FB		BNE	LOOP	if not zero, use value to go to next
000B		;			record
000B	98		TYA		
000C	6500		STA	0,x	store address of next record
000E		;			in link field of current record
000E	AA		TAX		
000F	7400		STZ	0,x	now store zero to link field of
0011		;			new record, which is now end

### Fragment 8.2

The routine hinges on the **BNE** instruction found half-way through the code; until the zero element is reached. the processor continues looping through as many linked records as exist. Notice that the routine has no need to know how many elements there are or to count them as it adds a new element. Figure 8.3 pictures such a linked list.

## The Western Design Center

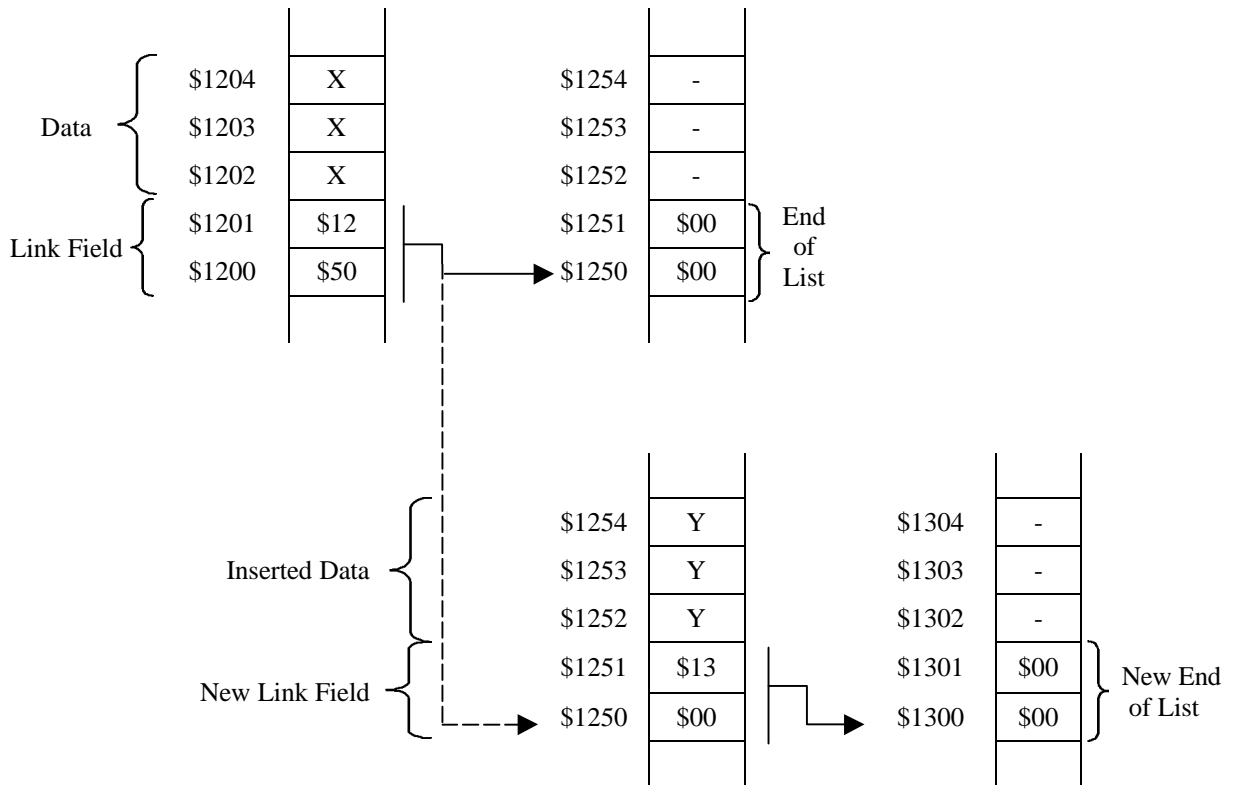

**Figure 8-3. Linked List**

The two conditional branch instructions that check the zero flag are also frequently used following a subtraction or comparison to evaluate the equality or inequality of two values. Their use in arithmetic, logical, and relational expressions will be covered in more detail, with examples, in the next few chapters.

### ***Branching Based on the Carry Flag***

The carry flag in the status register is affected by addition, subtraction, and shift instructions, as well as by two implied-addressing instructions that explicitly set or clear the carry (**SEC** and **CLC**) and, on the 65802/65816, by the emulation and carry swapping **XCE** instruction, and the **SEP** and **REP** instructions.

The **BCC** instruction (branch on carry clear) is used to branch when the carry flag is a zero. The **BCS** instruction (branch on carry set) is used to branch when the carry flag is a one.

The carry flag bit is the only condition code flag for which there are explicit instructions both to clear and to set it. (The decimal flag, which can also be set and cleared explicitly, is a mode-setting flag; there are no instructions to branch on the status of the decimal flag.) This can come in handy on the 6502, which has no branch-always instruction (only the non-relocatable absolute jump): branch-always can be faked by setting the carry, then branching on carry set:

38	SEC		set carry bit in status register
BOEB	BCS	NEWCODE	always document a BCS being used as branch-always

Since the code which follows this use of the **BCS** instruction will never be executed due to failure of the condition test, it should be documented as acting like a branch-always instruction.

The 6502 emulation mode of the 65802 and 65816 can be toggled on or off only by exchanging the carry bit with the emulation bit; so the only means of testing whether the processor is in emulation mode or native mode is to exchange the emulation flag with the carry flag and test the carry flag, as in Fragment 8.3. Note that **CLC**, **XCE**, and **BCS** instructions themselves always behave the same regardless of mode.

0000	.			
0000	.			
0000	18	CLC		shift to native mode
0001	FB	XCE		swap previous emulation bit value into carry
0002	B0FC	BCS	EMHAND	if was emulation, branch to emulation handler
0004	.			
0004	.			else processor in native mode
0004	.			
0004	.			

Fragment 8.3

Arithmetic and logical uses of branching based on the carry flag will be discussed in the next two chapters.

**Branching Based on the Negative Flag**

The negative flag bit in the status register indicates whether the result of arithmetic, logical, load, pull, or transfer operation is negative or positive when considered as a two’s-complement number. A negative result causes the flag to be set; a zero or positive result causes the flag to be cleared. The processor determines the sign of a result by checking to see if the high-order bit is set or not. A two’s-complement negative number will always have its high-order bit set, a positive number always has it clear.

The **BMI** (branch-minus) instruction is used to branch when a result is negative, or whenever a specific action needs to be taken if the high-order (sign) bit of a value is set. Execution of the **BPL** (branch-plus) instruction will cause a branch whenever a result is positive or zero – that is, when the high-order bit is clear.

The ease with which these instructions can check the status of the high order-bit has not been lost on hardware designers. For example, the AppleII keyboard is read by checking a specific memory location (remember, the 65x processor use memory-mapped I/O). Like most computer I/O devices, the keyboard generates ASCII codes in response to key presses. The code returned by the keyboard only uses the low-order seven bits; this leaves the eight bit free to be used as a special flag to determine if a key has been pressed since the last time a key was retrieved. To wait for a keypress, a routine (*see* Fragment 8.4) loops until the high-order bit of the keyboard I/O location is set.

0000	KEYBD	GEQU	\$C000	
0000	KSTRB	GEQU	\$C010	
0000				
0000	;			wait until a character is pressed at the keyboard
0000				
0000	E230	SEP	#\$30	eight-bit words are used for I/O
0002				
0002	AD00C0	LOOP	LDA	KEYBD
0005	10FB		BPL	LOOP
0007	8D10C0		STA	KSTRB
000A				
000A				continue execution having fetched key
000A				from keyboard
000A				

Fragment 8.4

The **STA KSTRB** instruction that follows a successful fetch is necessary to tell the hardware that a key has been read; it clears the high-order bit at the **KEYBD** location so that the next time the routine is called, it will again loop until the next key is pressed.

Remember that the high-order or sign bit is always bit seven on a 6502 or 65C02 or, on the 65802 and 65816, if the register loaded is set to an eight-bit mode. If a register being used on the 65802 or 65816 is set to sixteen-bit mode, however, then the high bit – the bit that affects the negative flag – is bit fifteen.

### Branching Based on the Overflow Flag

Only four instructions affect the overflow (**v**) flag on the 6502 and 65C02: adding, subtracting, bit-testing, and an instruction dedicated to explicitly clearing it. The 65802/65816's **SEP** and **REP** instructions can set and clear the overflow flag as well. The next chapter will discuss the conditions under which the flag is set or cleared.

The **BVS** instruction is used to branch when a result sets the overflow flag. The **BVC** instruction is used to branch when a result clears the overflow flag.

Additionally, there is a hardware input on the 6502, 65C02, and 65802 that causes the overflow flag to be set in response to a hardware signal. This input pin is generally left unconnected in most personal computer systems. It is more likely to be useful in dedicated control applications.

### Limitations of Conditional Branches

If you attempt to exceed the limits (+127 and -128) of the conditional branches by coding a target operand that is out of range, an error will result when you try to assemble it. If you should need a conditional branch with a longer reach, one solution is to use the inverse branch; if you would have used **BNE**, test it instead for equal to zero using **BEQ**. If the condition is true, target the next location past a jump to your real target. For example, Fragment 8.5 shows the end of a fairly large section of code, at the point at which it is necessary to loop back to the top (**TOP**) of the section if the value in location **CONTROL** is not equal to zero. You would use the code like Fragment 8.5 if **TOP** is more than 128 bytes back.

0000	AD0080	LDA	CONTROL	
0003	F003	BEQ	DONE	done processing; skip over loop back
0005	4C0080	JMP	TOP	control not equal to zero; loop again
0008		DONE	ANOP	go on to next phase of processing
0008		.		
0008		.		

Fragment 8.5

The price of having efficient two-byte short branches is that you must use five bytes to simulate a long conditional branch.

Many times it is possible and sensible to branch to another nearby flow of control statement and use it to puddle-jump to your final target. Sometimes you will find the branch or jump statement you need for puddle jumping already within your code because it's not unusual for two or more segments of code to conditionally branch to the same place. This method costs you no additional code, but you should document the intermediate branch, nothing that it's being used as a puddle-jump. Should you change it later, you won't inadvertently alter its use by the other branch.

Each of the 65x branch instructions is based on a single status bit. Some arithmetic conditions, however, are based on more than one flag being changed. There are no branch instructions available for the relations of *unsigned greater than* and *unsigned less than or equal to*, these relations can only be determined by examining more than one flag bit. There are also no branch instructions available for *signed* comparisons, other than *equal* and *not equal*. How to synthesize these options is described in the following chapter.

### Unconditional Branching

The 65C02 introduced the **BRA** branch always (or unconditional branch) instruction, to the relief of 6502 programmers; they had found that a good percentage of the jump instructions coded were for short distance within the range of a branch instruction.

Having an unconditional branch available makes creating relocatable code easier. Every program must have a starting address, or origin, specified, which tells the assembler where in memory the program will be

## The Western Design Center

loaded. This is necessary so that the assembler will be able to generate the correct values for locations defined by labels in the source code.

Consider Fragment 8.6, the beginning of a program that specifies an origin of \$2000. In order to make patching certain variables easier, they have been located right at the beginning of the program. When this program is assembled, location \$2000 holds a jump instruction, and the assembler gives its operand the value of the location of **BEGCODE**, that is, \$2005. If this program were then loaded at \$2200, instead of \$2000 as was “promised” by the **ORG** directive, it would fail because the very first instruction executed, at \$2200, would be the jump to \$2005. Since the program has now been loaded at \$2200, the contents of \$2005 are no longer as expected, and the program is in deep trouble.

By substituting an unconditional branch instruction for the jump, as in Fragment 8.7, the operand of the branch is now a relative displacement (the value two), and the branch instruction will cause two to be added to the current value of the counter program counter, whatever it may be. The result is that execution continues at **BEGCODE**, the same relative location the jump instruction transferred control to in the fixed-position version.

The code is now one byte shorter. Most importantly, though, this section of the

0000			ORG	\$2000	
0000		MAIN	START		
0000	4C0500		JMP	BEGCODE	jump around data to beginning code
0003	77	DATA1	DC	H'77'	
0004	88	DATA2	DC	H'88'	
0005		BEGCODE	ANOP		
0005			.		
0005			.		
0005			.		

**Fragment 8.6**

program is now position-independent. If executed at \$2000, the branch is located at \$2000; the program counter value before the branch's operand is added is \$2002; the result of the addition is \$2004, the location of **BEGCODE**. Load and execute the program instead at \$2200, and the branch is located at \$2200; the program counter value before the branch operand is added is \$2202; the result of the addition is \$2204, which is the new location of **BEGCODE**.

0000			ORG	\$2000	
0000		MAIN	START		
0000	8002		BRA	BEGCODE	branch around data to beginning code
0002	77	DATA1	DC	H'77'	
0003	88	DATA2	DC	H'88'	
0004	AD0200	BEGCODE	LDA	DATA1	
0007			.		
0007			.		
0007			.		
0007			.		

**Fragment 8.7**

Because the operand of a branch instruction is always relative to the program counter, its effective address can only be formed by using the program counter. Programs that use branches rather than jump may be located anywhere in memory.

6502 programmers in need of relocatability get around the lack of an unconditional branch instruction by using the technique described earlier of setting a flag to a known value prior to executing a branch-on-that-condition instruction.

Even with the unconditional branch instruction, however, relocatability can still be a problem if the need for branching extends beyond the limits imposed by its eight-bit operand. There is some help available on the 6502 and 65C02 in the form of the absolute indirect jump, which can be loaded with a target that is calculated at run time.



## The Western Design Center

The 65802 and 65816 introduce the **BRL** unconditional branch long instruction. This is the only 65x branch instruction which does not take an eight-bit operand: its operand, being sixteen bits, lets it specify a target anywhere within the current 64K program bank. It is coded like any other branch, except that the target label can be outside the range of the other branches. Obviously, a two-byte displacement is generated by the assembler, making this branch a three-byte instruction. If the effective address that results when the sixteen-bit displacement is added to the current program counter would extend beyond the 64K limit of the current program bank.

The **BRL** instruction can replace entirely the absolute **JMP** instruction in a relocatable program; the price is an extra execution cycle per branch.

## 9) Chapter Nine

### Built-In Arithmetic Functions

With this chapter you make your first approach to the heart of the beast: the computer as an automated calculator. Although their applications cover a broad range of functions, computers are generally associated first and foremost with their prodigious calculating abilities. Not without reason, for even in chapter oriented applications such as word processing, the computer is constantly calculating. At the level of the word processor itself, everything from instructions decoding to effective address generation is permeated by arithmetic or arithmetic-like operations. At the software implementation level, the program is constantly calculating horizontal and vertical cursor location, buffer pointer locations, indents, page numbers, and more.

But unlike dedicated machines, such as desk-top or pocket calculators, which are *merely* calculators, a computer is a flexible and generalized system which can be programmed and reprogrammed to perform an unlimited variety of functions. One of the keys to this ability lies in the computer's ability to implement control structures, such as loops, and to perform comparisons and select an action based on the result. Because this chapter introduces comparison, the elements necessary to demonstrate these features are complete. The other key element, the ability to branch on condition, was presented in the previous chapter. This chapter therefore contains the first examples of these control structures, as they are implemented on the 65x processor.

Armed with the material presented in Chapter 1 about positional notation as it applies to the binary and hexadecimal number systems, as well as the facts concerning two's-complement binary numbers and binary arithmetic, you should possess the background required to study the arithmetic instructions available on the 65x series of processors.

Consistent with the simple design approach of the 65x family, only elementary arithmetic functions are provided, as listed in Table 9.1, leaving the rest to be synthesized in software. There are, for example, no built-in integer multiply or divide. More advanced examples presented in later chapters will show how to synthesize these more complex operations.

Mnemonic	Available on:			Description
	6502	65C02	65802/816	
<i>Increment Instructions:</i>				
DEC	x	x	x	decrement
DEX	x	x	x	decrement index register X
DEY	x	x	x	decrement index register Y
INC	x	x	x	increment
INX	x	x	x	increment index register X
INY	x	x	x	increment index register Y
<i>Arithmetic Instructions:</i>				
ADC	x	x	x	add with carry
SBC	x	x	x	subtract with borrow
<i>Compare with Memory Instructions:</i>				
CMP	x	x	x	compare accumulator
CPX	x	x	x	compare index register X
CPY	x	x	x	compare index register Y

**Table 9-1 Arithmetic Instructions**

## Increment and Decrement

The simplest of the 65x arithmetic instructions are **increment** and **decrement**. In the case of the 65x processors, all of the increment and decrement operations add or subtract **one** to a number. (Some other processors allow you to increment or decrement by one, two, or more.)

There are several reasons for having special instructions to add or subtract one to a number, but the most general explanation says it all: the number one tends to be, by far, the most frequently added number in virtually any computer application. One reason for this is that **indexing** is used so frequently to access multi-byte data structures, such as address tables, character strings, multiple-precision numbers, and most forms of record structures. Since the items in a great percentage of such data structures are byte or double-byte wide, the index counter **step value** (the number of bytes from one array item to the next) is usually one or two. The 65x processors, in particular, have many addressing modes that feature indexing; that is, they use a value in one of the index registers as part of the effective address.

All 65x processors have four instructions to increment and decrement the index registers: **INX**, **INY**, **DEX**, and **DEY**. They are single-byte implied operand instructions and either add one to, or subtract one from, the **X** or **Y** register. They execute quite quickly – in two cycles – because they access no memory and affect only a single register.

All 65x processors also have a set of instructions for incrementing and decrementing memory, the **INC** and **DEC** instructions, which operate similarly. They too are unary operations, the operand being the data stored at the effective address specified in the operand field of the instruction. There are several addressing modes available to these two instructions. Note that, unlike the register increment and decrement instructions, the **INC** and **DEC** instructions are among the slowest-executing 65x instructions. That is because they are **Read-Modify-Write** operations: the number to be incremented or decremented must first be fetched from memory; then it is operated upon within the processor; and, finally, the modified value is written back to memory. Compare this with some of the more typical operations, where the result is left in the accumulator. Although read-modify-write instructions require many cycles to execute, each is much more efficient, both byte- and cycle-wise, than the three instructions it replaces – load, modify, and store.

In Chapter 6, you saw how the load operations affected the **n** and **z** flags depending on whether the loaded number was negative (that is, had its high bit set), or was zero. The 65x arithmetic functions, including the increment and decrement operations, also set the **n** and **z** status flags to reflect the result of the operation.

In Fragment 9.1, one is added to the value in the **Y** register, \$7FFF. The result is \$8000, which, since the high-order bit is turned on, may be interpreted as a negative two's-complement number. Therefore the **n** flag is set.

0000	C230	REP	#\$30	16-bit registers
0002		LONGA	ON	
0002		LONGI	ON	
0002	A0FF7F	LDY	#\$7FFF	\$7FFF is a positive number
0005	C8	INY		\$8000 is a negative number;n=1

**Fragment 9.1**

In a similar example, Fragment 9.2, the **Y** register is loaded with the highest possible value which can be represented in sixteen bits (all bits turned on).

0000	C230	REP	#\$30	
0002		LONGA	ON	
0002		LONGI	ON	
0002	A0FFFF	LDY	#\$FFFF	
0005	C8	INY		z = 1 in status register

**Fragment 9.2**

## The Western Design Center

If one is added to the unsigned value \$FFFF, the result is \$10000:

				1	one to be added
+	1111	1111	1111	1111	binary equivalent of \$FFFF
1	0000	0000	0000	0000	result is \$10000

Since there are no longer any extra bits available in the sixteen-bit register, however, the low-order sixteen bits of the number in **Y** (that is, zero) does not represent the actual result. As you will see later, addition and subtraction instructions use the **carry flag** to reflect a carry out of the register, indicating that a number larger than can be represented using the current word size (sixteen bits in the above example) has been generated. While increment and decrement instructions do not affect the carry, a zero result in the **Y** register after an increment (indicated by the **z** status flag being set) shows that a carry has been generated, even though the carry flag itself does not indicate this.

A classic example of this usage is found in Fragment 9.3, which shows the technique commonly used on the eight-bit 6502 and 65C02 to increment a sixteen-bit value in memory. Note the branch-on-condition instruction, **BNE**, which was introduced in the previous chapter, is being used to indicate if any overflow from the low byte requires the high byte to be incremented, too. As long as the value stored at the direct page location **ABC** is non-zero following the increment operation, processing continues at the location **SKIP**. If **ABC** is zero as a result of the increment operation, a page boundary has been crossed, and the high order byte of the value must be incremented, the sixteen-bit value would “wrap around” within the low byte.

0000	EE0080	TOP	INC	ABC	increment low byte
0003	D0FB		BNE	SKIP	if no overflow, done
0005	EE0180		INC	ABC+1	if overflow: increment high byte, too
0008		SKIP	.		continue
0008			.		
0008			.		
0008			.		

### Fragment 9.3

Such use of the **z** flag to detect carry (or borrow) is peculiar to the increment and decrement operations: if you could increment or decrement by values other than one, this technique would not work consistently, since it would be possible to cross the “threshold” (zero) without actually “landing” on it (you might, for example, go from \$FFFF to \$0001 if the step value was 2).

A zero result following a decrement operation, on the other hand, indicates that the *next* decrement operation will cause a borrow to be generated. In Fragment 9.4, the **Y** register is loaded with one, and then one is subtracted from it by the **DEY** instruction. The result is clearly zero; however, if **Y** is decremented again, \$FFFF will result. If you are treating the number as a signed, two’s-complement number, this is just fine, as \$FFFF is equivalent to a sixteen-bit, negative one. But if it is an unsigned number, a borrow exists.

0000	C230	REP	#\$30	16-bit registers
0002		LONGA	ON	
0002		LONGI	ON	
0002	A00100	LDY	#\$0001	z = 0 in the status register
0005	88	DEY		z = 1 in the status register

### Fragment 9.4

Together with the branch-on-condition instructions introduced in the previous chapter, you can now efficiently implement one of the most commonly used control structures in computer programming,, the **program loop**.

A rudimentary loop would be a zero-fill loop; that is, a piece of code to fill a range of memory with zeroes. Suppose, as in Listing 9.1, the memory area from \$4000 to \$5FFF was to be zeroed (for example, to clear hi-res page two graphics memory in the AppleII). By loading an index register with the size of the area to be cleared, the memory can be easily accessed by indexing from an absolute base of \$4000.

## The Western Design Center

The two lines at **BASE** and **COUNT** assign symbolic names to the starting address and length of the fill area. The **REP** instruction puts the processor into the long index/long accumulator mode. The long index allows the range of memory being zeroed to be greater than 256 bytes; the long accumulator provides for faster zeroing of memory, by clearing two bytes with a single instruction.

The loop is initialized by loading the **X** register with the value **COUNT**, which is the number of bytes to be zeroed. The assembler is instructed to subtract two from the total to allow for the fact that the array starts at zero, rather than one, and for the fact that two bytes are cleared at a time.

0001	0000					
0002	0000			KEEP	KL.9.1	
0003	0000			65816	ON	
0004	0000		L91	START		
0005	0000					
0006	0000	18		CLC		
0007	0001	FB		XCE		
0008	0002					
0009	0002					
0010	0002		BASE	GEQU	\$4000	starting address of fill area
0011	0002		COUNT	GEQU	\$2000	number of bytes to clear
0012	0002					
0013	0002	C230		REP	#\$30	turn 16-bit modes on
0014	0004					
0015	0004			LONGA	ON	
0016	0004			LONGI	ON	
0017	0004					
0018	0004	A2FE1F		LDX	#COUNT-2	get the number of bytes to clear into x
0019	0007					minus two
0020	0007					
0021	0007	9E0040	LOOP	STZ	BASE,X	store zero to memory
0022	000A	CA		DEX		
0023	000B	CA		DEX		
0024	000C	10F9		BPL	LOOP	repeat loop again if not done
0025	000E					
0026	000E	38	DONE	SEC		
0027	000F	FB		XCE		
0028	0010	60		RTS		
0029	0011					
0030	0011			END		

Listing 9.1

The loop itself is then entered for the first time, and the **STZ** instruction is used to clear the memory location formed by adding the index register to the constant **BASE**. Next come two decrement instructions; two are needed because the **STZ** instruction stored a double-byte zero. By starting at the end of the memory range and indexing down, it is possible to use a single register for both address generation and loop control. A simple comparison, checking to see that the index register is still positive, is all that is needed to control the loop.

Another concrete example of a program loop is provided in Listing 9.2, which toggles the built-in speaker in an AppleII computer with increasing frequency, resulting in a tone of increasing pitch. It features an outer driving loop (**TOP**), an inner loop that produces a tone of a given pitch, and an inner-most delay loop. The pitch of the tone can be varied by using different initial values for the loop indices.

## The Western Design Center

0001	0000			KEEP	KL.9.2	
0002	0000			65816	ON	
0003	0000					
0004	0000		L92	START		
0005	0000	18		CLC		
0006	0001	FB		XCE		
0007	0002	E230		SEP	#\$30	set 8-bit mode
0008	0004			LONGA	OFF	
0009	0004			LONGI	OFF	
0010	0004		BELL	GEQU	\$C030	
0011	0004					
0012	0004	A200		LDX	#0	
0013	0006	8A		TXA		X, now in A, initializes the delay loop
0014	0007					
0015	0007	9B	TOP	TXY		initialize X & Y to 0
0016	0008					
0017	0008	8D30C0	LOOP	STA	BELL	accessing the tone generator pulses it
0018	000B					
0019	000B	8A		TXA		diminishing delay loop
0020	000C					
0021	000C	3A	DELAY	DEC	A	
0022	000D	D0FD		BNE	DELAY	loop 256 times before continuing
0023	000F					
0024	000F					
0025	000F	88		DEY		
0026	0010	D0F6		BNE	LOOP	
0027	0012					
0028	0012	CA		DEX		
0029	0013	D0F2		BNE	TOP	
0030	0015					
0031	0015	38		SEC		
0032	0016	FB		XCE		
0033	0017	60		RTS		
0034	0018			END		

Listing 9.2

### Addition and Subtraction: Unsigned Arithmetic

The 65x processors have only two dedicated general purpose arithmetic instructions: add with carry, **ADC**, and subtract with carry, **SBC**. As will be seen later, it is possible to synthesize all other arithmetic functions using these and other 65x instructions.

As the names of these instructions indicate, the carry flag from the status register is involved with the two operations. The role of the carry flag is to “link” the individual additions and subtractions that make up multiple-precision arithmetic operations. The earlier example of the 6502 sixteen-bit increment was a special case of the multiple-precision arithmetic technique used on the 65x processors, the link provided in that case by the **BNE** instruction.

Consider the addition of two decimal numbers, **56** and **72**. You begin your calculation by adding six to two. If you are working the calculation out on paper, you place the result, eight, in the right-most column, the one’s place:

$$\begin{array}{r} 56 \\ + 72 \\ \hline 8 \end{array}$$

## The Western Design Center

Next you add the ten's column; 5 plus 7 equals 12. The two is placed in the tens place of the sum, and the one is a carry into the 100's place. Normally, since you have plenty of room on your worksheet, you simply pencil in the one to the left of the two, and you have the answer.

The situation within the processor when it adds two numbers is basically similar, but with a few differences. First, the numbers added and subtracted in a 65x processor are normally binary numbers (although there is also a special on-the-fly decimal adjust mode for adding and subtracting numbers in binary-coded decimal format). Just as you began adding, the processor starts in the right-most column, or one's place, and continues adding columns to the left. The augend (the number added to) is always in the accumulator; the location of the addend is specified in the operand field of the instruction. Since a binary digit can only be a zero or a one, the addition of 2 ones results in a zero in the current column and a carry into the next column. This process of addition continues until the highest bit of the accumulator has been added (the highest bit being either bit seven or, alternatively on the 65802 / 65816, bit fifteen, if the **m** flag is cleared). But suppose that \$82 is added to \$AB in the eight-bit accumulator:

	1		1	carry digits from previous addition to right
	1000		0010	binary equivalent of \$82
+	1010		1011	binary equivalent of \$AB
	<u>0010</u>		<u>1101</u>	

If you begin by adding the binary digits from the right and marking the sum in the proper column, and then placing any carry that results at the top of the next column to the left, you will find that a carry results when the ones in column seven are added together. However, since the accumulator is only eight bits wide, there is no place to store this value; the result has “overflowed” the space allocated to it. In this case, the final carry is stored in the carry flag after the operation. If there had been no carry, the carry flag would be reset to zero.

The automatic generation of a carry flag at the end of an addition is complemented by a second feature of this instruction that is executed at the beginning of the instruction: the **ADC** instruction itself always adds the previously generated one-bit carry flag value with the right-most column of binary digits. Therefore, it is always necessary to explicitly clear the carry flag before adding two numbers together, unless the numbers being added are succeeding words of a multi-word arithmetic operation. By adding in a previous value held in the carry flag, and storing a resulting carry there, it is possible to chain together several limited-precision (each only eight or sixteen bits) arithmetic operations.

First, consider how you would represent an unsigned binary number greater than \$FFFF (decimal 65,536) – that is, one that cannot be stored in a single double-byte cell. Suppose the number is \$023A8EF1. This would simply be stored in memory in four successive bytes, from low to high order, as follows, beginning at \$1000:

1000	-	F1
1001	-	8E
1002	-	3A
1003	-	02

Since the number is greater than the largest available word size of the processor (double byte), any arithmetic operations performed on this number will have to be treated as multiple-precision operations, where only one part of a number is added to the corresponding part of another number at a time. As each part is added, and so on, until all of the parts of the number have been added.

Multiple-precision operations always proceed from low-order part to high-order part because the carry is generated from low to high, as seen in our original addition of decimal 56 to 72.

Listing 9.3 is an assembly language example of the addition of multi-precision numbers \$023A8EF1 to \$0000A2C1. This example begins by setting the accumulator word size to sixteen bits, which lets you process half of the four-byte addition in a single operation. The carry flag is then cleared because there must be no initial carry when an add operation begins. The two bytes stored at **BIGNUM** and **BIGNUM+1** are loaded into the double-byte accumulator. Note that the **DC 14** assembler directive automatically stores the four-byte integer constant value in memory in low-to-high order. The **ADC** instruction is then executed, adding \$8EF1 to \$A2C1.



## The Western Design Center

0001	0000		KEEP	KL.9.3	
0002	0000		65816	ON	
0003	0000				
0004	0000	L93	START		
0005	0000	18	CLC		
0006	0001	FB	XCE		
0007	0002	S220	REP	#\$20	use sixteen-bit accumulator
0008	0004		LONGA	ON	
0009	0004	18	CLC		make sure carry is clear to start
0010	0005	AD1A00	LDA	BIGNUM	load low-order two bytes
0011	0008	6D1E00	ADC	NEXTNUM	add to low-order two bytes of NEXTNUM
0012	000B	8D2200	STA	RESULT	save low-order result
0013	000E	AD1C00	LDA	BIGNUM+2	now load high-order two bytes
0014	0011	6D2000	ADC	NEXTNUM+2	add to high order of NEXTNUM with carry
0015	0014	8D2400	STA	RESULT+2	save result
0016	0017	38	SEC		
0017	0018	FB	XCE		
0018	0019	60	RTS		
0019	001A	F18E3A02	BIGNUM	DC	I4'\$023A8EF1'
0020	001E	C1A20000	NEXTNUM	DC	I4'\$0000A2C1'
0021	0022	00000000	RESULT	DS	4
0022	0026		END		

**Listing 9.3**

Examine the equivalent binary addition:

1	1	11	1	1	1	carry from addition of column to right
1000	1110	1111	0001			\$8EF1
1010	0010	1100	0001			\$A2C1
0011	0001	1011	0010			\$31B2

The sixteen-bit result found in the accumulator after the **ADC** is executed is \$31B2; however, this is clearly incorrect. The correct answer, \$13B2, requires seventeen bits to represent it, so an additional result of the **ADC** operation in this case is that the carry flag in the status register is set. Meanwhile, since the value in the accumulator consists of the correct low-order sixteen bits, the accumulator is stored at **RESULT** and **RESULT+1**.

With the partial sum of the last operation saved, the high-order sixteen bits of **BIGNUM** are loaded (from **BIGNUM+2**) into the accumulator, followed immediately by the **ADC NEXTNUM + 2** instruction, which is not preceded by **CLC** this time. For all but the first addition of a multiple-precision operation, the carry flag is not cleared; rather, the setting of the carry flag from the previous addition is allowed to be automatically added into the next addition. You will note in the present example that the high-order sixteen bits of **NEXTNUM** are zero; it almost seems unnecessary to add them. At the same time, remember that there was a carry left over from the first addition; when the **ADC NEXTNUM + 2** instruction is executed, this carry is automatically added in; that is, the resulting value in the accumulator is equal to the carry flag (1) plus the original value in the accumulator (\$023A) plus the value at the address **NEXTNUM + 2** (\$0000), or \$023B. This is then stored in the high-order bytes of **RESULT**, which leaves the complete, correct value stored in locations **RESULT** through **RESULT + 3** in low-high order:

RESULT	-	B2
RESULT + 1	-	31
RESULT + 2	-	3B
RESULT + 3	-	02

Reading from high to low, the sum is \$023B31B2.

This type of multiple precision addition is required constantly on the eight-bit 6502 and 65C02 processors in order to manipulate addresses, which are sixteen-bit quantities. Since the 65816 and 65802 provide sixteen-bit arithmetic operations when the **m** flag is cleared, this burden is greatly reduced. If you wish,

## The Western Design Center

however, to manipulate long addresses on the 65816, that is, 24-bit addresses, you will similarly have to resort to multiple precision. Otherwise, it is likely that multiple-precision arithmetic generally will only be required on the 65802 or 65816 in math routines to perform number-crunching on user data, rather than for internal address manipulation.

An interesting footnote to the multiple-precision arithmetic comparison between the 6502 and the 65816 is to observe that since the 6502 only has an eight-bit adder, even those instructions that automatically perform sixteen-bit arithmetic (such as branch calculation and affective address generation) require an additional cycle to perform the addition of the high-order byte of the address. The presence of a sixteen-bit adder within the 65802 and 65816 explains how it is able to shave cycles off certain operations while in native mode, such as branching across page boundaries, where an eight-bit quantity is added to a sixteen-bit value. On the 6502, if a page boundary isn't crossed, the high byte of the sixteen-bit operand is used as-is; if a carry is generated by adding the two low bytes, a second eight-bit add must be performed, requiring an additional machine cycle. On the 65816, the addition is treated as a single operation.

Subtraction on the 65x processors is analogous to addition, with the borrow serving a similar role in handling multiple-precision subtractions. On the 65x processors, the carry flag is also used to store a subtraction's borrow. In the case of the addition operation, a one stored in the carry flag indicates that a carry exists, and the value in the carry flag will be added into the next add operation. The borrow stored in the carry flag is actually an inverted borrow: that is, the carry flag cleared to zero means that there is a borrow, while carry set means that there is none. Thus prior to beginning a subtraction, the carry flag should be *set* so that no borrow is subtracted by the **SBC** instruction.

Although you can simply accept this rule at face value, the explanation is interesting. The simple way to understand the inverted borrow of the 65x series is to realize that, like most computers, a 65x processor has no separate subtraction circuits as such; all it has is an adder, which serves for both addition and subtraction. Obviously, addition of a negative number is the same as subtraction of a positive. To subtract a number, then, the value which is being subtracted is inverted, yielding a one's-complement negative number. This is then added to the other value and, as is usual with addition on the 65x machines, the carry is added in as well.

Since the add operation automatically adds in the carry, if the carry is set prior to subtraction, this simply converts the inverted value to two's complement form. (Remember, two's complement is formed by inverting a number and adding one; in this case the added one is the carry flag.) If, on the other hand, the carry was clear, this has the effect of subtracting one by creating a two's-complement number which is one greater than if the carry had been presented. (Assuming a negative number is being formed, remember that the more negative a number is, the greater its value as an unsigned number, for example, \$FFFF = -1, \$8000 = -32767.) Thus, if a borrow exists, a value which is more negative by one is created, which is added to the other operand, effectively subtracting a carry.

## Comparison

The comparison operation – is **VALUE1** equal to **VALUE2**, for example – is implemented on the 65x, as on most processors, as an implied subtraction. In order to compare **VALUE1** to **VALUE2**, one of the values is subtracted from the other. Clearly, if the result is zero, then the numbers are equal.

This kind of comparison can be made using the instructions you already know, as Fragment 9.5 illustrates. In this fragment, you can see that the branch to **TRUE** will be taken, and the **INC VAL** instruction never executed, because \$1234 minus 1234 equals zero. Since the results of subtractions condition the **z** flag, the **BEQ** instruction (which literally means “branch if result equal to zero”), in this case, means “branch if the compared values are equal.”

0000	C230	REP	#\$30	16-bit registers
0002		LONGA	ON	
0002		LONGI	ON	
0002				
0002	9C1200	STZ	VAL	clear double-byte at VAL
0005	A93412	LDA	#\$1234	get one value
0008	38	SEC		
0009	E93412	SBC	#\$1234	subtract another
000C	F003	BEQ	TRUE	if they are the same, leave VAL zero
000E	EE1200	INC	VAL	if they are different, set VAL
0011	60	TRUE	RTS	
0012	0000	VAL	DS	2

Fragment 9.5

There are two undesirable aspects of this technique, however, if comparison is all that is desired rather than actual subtraction. First, because the 65x subtraction instruction expects the carry flag to be set for single precision subtractions, the **SBC** instruction must be executed before each comparison using **SBC**. Second, it is not always desirable to have the original value in the accumulator lost when the result of the subtraction is stored there.

Because comparison is such a common programming operation, there is a separate compare instruction, **CMP**. Compare subtracts the value specified in the operand field of the instruction from the value in the accumulator *without* storing the result; the original accumulator value remains intact. Status flags normally affected by a subtraction – z, n, and c – are set to reflect the result of the subtraction just performed. Additionally, the carry flag is automatically set before the instruction is executed, as it should be for a single-precision subtraction. (Unlike the **ADC** and **SBC** instructions, **CMP** does not set the overflow flag, complicating signed comparisons somewhat, a problem which will be covered later in this chapter.)

Given the flags that are set by the **CMP** instruction, and the set of branch-on-condition instructions, the relations shown in Table 9.2 can be easily tested for. **A** represents the value in the accumulator, **DATA** is the value specified in the operand field of the instruction, and **Bxx** is the branch-on-condition instruction that causes a branch to be taken (to the code labelled **TRUE**) if the indicated relationship is true after a comparison.

Because the action taken after a comparison by the **BCC** and **BCS** is not immediately obvious from their mnemonic names, the recommended assembler syntax standard allows the alternate mnemonics **BLT**, for “branch on less than,” and **BGE**, for

BEQ	TRUE	branch if A = DATA
BNE	TRUE	branch if A <> DATA
BCC	TRUE	branch if A < DATA
BCS	TRUE	branch if A >= DATA

Table 9-2. Equalities

“branch if greater of equal,” respectively, which generate the identical object code.

Other comparisons can be synthesized using combinations of branch-on-condition instructions. Fragment 9.6 shows how the operation “branch on greater than” can be synthesized.

0000	F002	BEQ	SKIP	branch to TRUE if
0002	B0FC	BGE	TRUE	A > DATA
0004		SKIP	ANOP	

Fragment 9.6

Fragment 9.7 shows “branch on less or equal.”

## The Western Design Center

0000	FOFE	BEQ	TRUE	branch if
0002	90FC	BCC	TRUE	A <= DATA

### Fragment 9.7

Listing 9.4 features the use of the compare instruction to count the number of elements in a list which are less than, equal to, and greater than a given value. While of little utility by itself, this type of comparison operation is just a few steps away from a simple sort routine. The value the list will be compared against is assumed to be stored in memory locations \$88.89, which are given the symbolic name **VALUE** in the example. The list, called **TABLE**, uses the **DC I** directive, which stores each number as a sixteen-bit integer.

## The Western Design Center

0001	0000		KEEP	KL.9.4	
0002	0000		65816	ON	
0003	0000				
0004	0000	L94	START		
0005	0000				
0006	0000				
0007	0000	LESS	GEQU	\$82	counter
0008	0000	SAME	GEQU	\$84	counter
0009	0000	MORE	GEQU	\$86	counter
0010	0000				
0011	0000	VALUE	GEQU	\$88	value for list to be compared against
0012	0000				
0013	0000	18	CLC		
0014	0001	FB	XCE		
0015	0002	C230	REP	#\$30	turn on both 16-bit modes
0016	0004				
0017	0004		LONGA	ON	
0018	0004		LONGI	ON	
0019	0004				
0020	0004				
0021	0004	6482	STZ	LESS	zero the counters
0022	0006	6484	STZ	SAME	
0023	0008	6486	STZ	MORE	
0024	000A				
0025	000A				
0026	000A	A588	LDA	VALUE	get the comparison value
0027	000C	A01A00	LDY	#LAST-TABLE	get a counter to # of list items
0028	000F				
0029	000F				
0030	000F	D92700	TOP	CMP	TABLE,Y
0031	0012	F006		BEQ	ISEQ
0032	0014	9008		BLT	ISMORE
0033	0016	E682		INC	LESS
0034	0018	8006		BRA	LOOP
0035	001A	E684	ISEQ	INC	SAME
0036	001C	8002		BRA	LOOP
0037	001E	E686	ISMORE	INC	MORE
0038	0020				
0039	0020	88	LOOP	DEY	move pointer to next list item
0040	0021	88		DEY	
0041	0022	10EB		BPL	TOP
0042	0024		;		continue if there are any list items left to compare
0043	0024				
0044	0024	38		SEC	
0045	0025	FB		XCE	
0046	0026	60		RTS	
0047	0027				
0048	0027	0C00009000		DC	I'12,9,302,956,123,1234,98'
0049	0035	04116300		DC	I'4356,99,11,40000,23145,562'
0050	0041	0F27	LAST	DC	I'9999''
0051	0043				
0052	0043			END	

**Listing 9.4.**

After setting the mode to sixteen-bit word/index size, the locations that will hold the number of occurrences of each of the three possible relationships are zeroed. The length of the list is loaded into the Y register. The accumulator is loaded with the comparison value.

The loop itself is entered, with a comparison to the first item in the list; in this and each succeeding case, control is transferred to counter-incrementing code depending on the relationship that exists. Note that equality and less-than are tested first, and greater-than is assumed if control falls through. This is necessary since there is no branch on greater-than (only branch on greater-than-or-equal). Following the incrementing of the selected relation-counter, control passes either via an unconditional branch, or by falling through, to the loop-control code, which decrements Y twice (since double-byte integers are being compared). Control

## The Western Design Center

resumes at the top of the loop unless all of the elements have been compared, at which point **Y** is negative, and the routine ends.

In addition to comparing the accumulator with memory, there are instructions for comparing the values in the two index registers with memory, **CPX** and **CPY**. These instructions come in especially handy when it is not convenient or possible to decrement an index to zero – if instead you must increment or decrement it until a particular value is reached. The appropriate compare index register instruction is inserted before the branch-on-condition instruction either loops or breaks out of the loop. Fragment 9.8 shows a loop that continues until the value in **X** reaches **\$A0**.

0000	LOOP	ANOP		work to be done in the loop goes here
0000		.		
0000		.		
0000		.		
0000	E8	INX		
0001	E0A000	CPX	#\$A0	
0004	D0FA	BNE	LOOP	continue incrementing X until
0006		ANOP		X = \$A0, so loop ended

**Fragment 9.8**

## Signed Arithmetic

The examples so far have dealt with unsigned arithmetic – that is, addition and subtraction of binary numbers of the same sign. What about signed numbers?

As you saw in Chapter 1, signed numbers can be represented using **two's-complement** notation. The two's complement of a number is formed by inverting it (one bits become zeroes, zeroes become ones) and then adding one. For example, a negative one is represented by forming the two's complement of one:

0000	0000	0000	0001	-binary one in sixteen-bit word
1111	1111	1111	1110	-complement word
0000	0000	0000	0001	-add one to complement
1111	1111	1111	1111	-result is two's-complement representation of minus one

Minus one is therefore equivalent to a hexadecimal \$FFFF. But as far as the processor is concerned, the unsigned value \$FFFF (65,535 decimal) and the signed value minus-one are equivalent. They both amount to the same stream of bits stored in a register. It's the interpretation of them given by the programmer which is significant – an interpretation that must be consistently applied across each of the steps that perform a multi-step function.

Consider all of the possible signed and unsigned numbers that can be represented using a sixteen-bit register. The two's complement of \$0002 is \$FFFE – as the positive numbers increase, the two's-complement (negative) numbers decrease (in the unsigned sense). Increasing the positive value to \$7FFF (%0111 1111 1111 1111), the two's complement is \$8001 (%1000 0000 0000 0001); except for \$8000, all of the possible values have been used to represent the respective positive and negative numbers between \$0001 and \$7FFF.

Since their point of intersection, \$8000, determines the maximum range of a signed number, the high-order bit (bit fifteen will always be one if the number is negative, and zero if the number is positive. Thus the range of possible binary values (%0000 0000 0000 0000 through %1111 1111 1111 1111, or \$0000 . . \$FFFF), using two's-complement form, is divided evenly between representations of positive numbers, and representations of the corresponding range of negative numbers. Since \$8000 is also negative, there seems to be one more possible negative number than positive; for the purpose here, however, zero is considered positive.

The high-order bit is therefore referred to as the **sign bit**. On the 6502, with its eight-bit word size (or the 65816 in an eight-bit register mode), bit seven is the sign bit. With sixteen-bit registers, bit fifteen is the sign bit. The **n** or negative flag in the status register reflects whether or not the high-order bit of a given register is set or clear after execution of operations which affect that register, allowing easy determination of the sign of a signed number by using either the **BPL** (branch on plus) or **BMI** (branch if minus) instructions introduced in the last chapter.

## The Western Design Center

Using the high-order bit as the sign bit sacrifices the carry flag's normal (unsigned) function. If the high-order bit is used to represent the sign, then the addition or subtraction of the sign bits (plus a possible carry out of the next-to-highest bit) results in a sign bit that may be invalid and that will erroneously affect the carry flag.

To deal with this situation, the status register provides another flag bit, the **v** or **overflow** flag, which is set or reset as the result of the **ADC** and **SBC** operations. The overflow bit indicates whether a signed result is too large (or too small) to be represented in the precision available, just as the carry flag does for unsigned arithmetic.

Since the high-order bit is used to store the sign, the penultimate bit (the next highest bit) is the high-order bit as far as magnitude representation is concerned. If you knew if there was a carry out of this bit, it would obviously be helpful in determining overflow or underflow.

However, the overflow flag is not simply the carry out bit six (if **m** = 1 for eight-bit mode) or bit fourteen (if **m** = 0 for sixteen-bit mode). Signed generation of the **v** flag is not as straightforward as unsigned generation of the carry flag. It is not automatically true that if there is a carry out of the penultimate bits that overflow has occurred, because it could also mean that the sign has changed. This is because of the circular or wraparound nature of two's-complement representation.

Consider Fragment 9.9. Decimal values with sign prefixes are used for emphasis (and convenience) as the immediate operands in the source program; their hexadecimal values appear in the left-hand column which interlists the generated object code (opcode first, low byte, high byte). You can see that -10 is equivalent to \$FFF6 hexadecimal, while 20 is hexadecimal \$0014. Examine this addition operation in binary:

0000	C230	REP	#\$30	16-bit registers
0002		LONGA	ON	
0002		LONGI	ON	
0002				
0002	A9F6FF	LDA	#-10	
0005	18	CLC		
0006	691400	ADC	#20	

**Fragment 9.9**

Two things should become clear: that the magnitude of the result (10 decimal) is such that it will easily fit within the number of bits available for its representation, and that there is a carry out of bit fourteen:

1	1111	1111	111	1	carry from previous bit
	1111	1111	1111	0110	-10 decimal
	0000	0000	0001	0100	+20 decimal
1	0000	0000	0000	1010	result is +10 decimal

In this case, the overflow flag is not set, because the carry out of the penultimate bit indicates **wraparound** rather than overflow (or underflow). Whenever the two operands are different signs, carry out of the next-to-highest bit indicates wraparound; the addition of a positive and a negative number (or *vice versa*) can result in a number too large (try it), but it may result in wraparound.

Conversely, overflow exists in the addition of two negative numbers if **no** carry results from the addition of the next-to-highest (penultimate) bits. If two negative numbers are added without overflow, they will always wrap around, resulting in a carry out of the next-to-highest bit. When wraparound has occurred, the sign bit is set due to the carry out of the penultimate bit. In the case of the two negative numbers being added (which always produces a negative result), this setting of the sign bit results in the correct sign. In the case of the addition of two positive numbers, wraparound never occurs, so a carry out of the penultimate bit always means that the overflow flag will be set.

These rules likewise apply for subtraction; however, you must consider that subtraction is really an addition with the sign of the addend inverted, and apply them in this sense.

In order for the processor to determine the correct overflow flag value, it exclusive-or's the carry out of the penultimate bit with the carry out of the high-order bit (the value that winds up in the carry flag), and sets or

## The Western Design Center

resets the overflow according to the result. By taking the exclusive-or of these two values, the overflow flag is set according to the rules above.

Consider the possible results:

- *If both values are positive*, the carry will be clear; if there is no penultimate carry, the overflow flag, too, will be clear, because 0 **XOR** 0 equals 0; the value in the sign bit is zero, which is correct because a positive number plus a positive number always equals a positive number. On the other hand, if there is a penultimate carry, the sign bit will change. While there is still no final carry, overflow is set. The final carry (clear) **xor** penultimate carry (set) equals one. Whenever overflow is set, the sign bit of the result has the wrong value.
- *If the signs are different*, and there is a penultimate carry (which means wraparound in this case), there will be a final carry. But when this is exclusive-or'd with the penultimate carry, it is canceled out, resulting in overflow being cleared. If, though, there were no penultimate carry, there would be no final carry; again, 0 **XOR** 0 = 0, or overflow clear. If the sign bit is cleared by the addition of a penultimate carry and the single negative sign bit, since wraparound in this case implies the translation from a negative to a positive number, the sign (clear) is correct. If there was no wraparound, the result is negative, and the sign bit is also correct (set).
- Finally, *if both signs are negative*, there will always be a carry out of the sign bit. A carry out of the penultimate bit means wraparound (with a correctly negative result), so carry (set) **XOR** penultimate carry (set) equals zero and the overflow flag is clear. If, however, there is no carry, overflow (or rather, underflow) has occurred, and the overflow is set because **XOR** no carry equals one.

The net result of this analysis is that, with the exception of overflow detection, signed arithmetic is performed in the same way as unsigned arithmetic. Multiple-precision signed arithmetic is also done in the same way as unsigned multiple-precision arithmetic; the sign of the two numbers is only significant when the high-order word is added.

When overflow is detected, it can be handled in three ways: treated as an error, and reported; ignored; or responded to by attempting to extend the precision of the result. Although this latter case is not generally practical, you must remember that, in this case, the value in the sign bit will have been inverted. Having determined the correct sign, the precision may be expanded using **sign extension**, if there is an extra byte of storage available and your arithmetic routines can work with a higher-precision variable. The method for extending the sign of a number involves the bit manipulation instructions described in the next chapter; an example of it is found there.

## Signed Comparisons

The principle of signed comparisons is similar to that of unsigned comparisons: the relation of one operand to another is determined by subtracting one from the other. However, the 65x **CMP** instruction, unlike **SBC**, does not affect the **v** flag, so does not reflect signed overflow/underflow. Therefore, signed comparisons must be performed using the **SBC** instruction. This means that the carry flag must be set prior to the comparison (subtraction), and that the original value in the accumulator will be replaced by the difference. Although the value of the difference is not relevant to the comparison operation, the sign is. If the sign of the result (now in the accumulator) is positive (as determined according to rules outlined above for proper determination of the sign of the result of a signed operation), then the value in memory is less than the original value in the accumulator; if the sign is negative, it is greater. If, though, the result of the subtraction is zero, then the values were equal, so this should be checked for first.

The code for signed comparisons is similar to that for signed subtraction. Since a correct result need not be completely formed, however, overflow can be tolerated since the goal of the subtraction is not to generate a result that can be represented in a given precision, but only to determine the relationship of one value to another. Overflow must still be taken into account in correctly determining the sign. The value of the sign bit (the high-order bit) will be the correct sign of the result unless overflow has occurred. In that case, it is the inverted sign.

Listing 9.5 does a signed comparison of the number stored in **VAL1** with the number stored in **VAL2**, and sets **RELATION** to minus one, zero, or one, depending on whether **VAL1 < VAL2**, **VAL1 = VAL2** or **VAL1 > VAL2**, respectively:



## The Western Design Center

0001	0000			KEEP	KL.9.5	
0002	0000			65816	ON	
0003	0000					
0004	0000		COMPARE	START		
0005	0000					
0006	0000	18		CLC		
0007	0001	FB		XCE		
0008	0002	C230		REP	#\$30	turn 16-bit modes on
0009	0004					
0010	0004			LONGA	ON	
0011	0004			LONGI	ON	
0012	0004					
0013	0004	9C2500		STZ	RELATION	clear result cell
0014	0007	AD2100		LDA	VAL1	
0015	000A	38		SEC		
0016	000B	ED2300		SBC	VAL2	
0017	000E	F00E		BEQ	SAME	
0018	0010	7007		BVS	INVERT	if v set, invert meaning of sign
0019	0012	3007		BMI	LESS	bra if VAL1 is less than VAL2
0020	0014	EE2500	GREATER	INC	RELATION	VAL1 is greater than VAL2
0021	0017	8005		BRA	SAME	
0022	0019	30F9	INVERT	BMI	GREATER	invert: bra if minus: minus = greater
0023	001B	CE2500	LESS	DEC	RELATION	
0024	001E	38	SAME	CLC		
0025	001F	FB		XCE		
0026	0020	60		RTS		
0027	0021					
0028	0021	0000	VAL1	DS	2	
0029	0023	0000	VAL2	DS	2	
0030	0025	0000	RELATION	DS	2	
0031	0027					
0032	0027			END		

Listing 9.5

## Decimal Mode

All of the examples in this chapter have dealt with binary numbers. In certain applications, however, such as numeric I/O programming, where conversion between ASCII and binary representation of decimal strings is inconvenient, and business applications, in which conversion of binary fractions to decimal fractions results in approximation errors, it is convenient to represent numbers in decimal form and, if possible, perform arithmetic operations on them directly in this form.

Like most processors, the 65x series provides a way to handle decimal representations of numbers. Unlike most processors, it does this providing a special **decimal mode** that causes the processor to use decimal arithmetic for **ADC**, **SBC**, and **CMP** operations, with automatic “on the fly” decimal adjustment. Most other microprocessors, on the other hand, do all arithmetic the same, requiring a second “decimal adjust” operation to convert back to decimal form the binary result of arithmetic performed on decimal numbers. As you remember from Chapter 1, binary-coded-decimal (BCD) digits are represented in four bits as binary values from zero to nine. Although values from \$A to \$F (ten to fifteen) may also be represented in four bits, these bit patterns are illegal in decimal mode. So when \$03 is added to \$09, the result is \$12, not \$0C as in binary mode. Each four-bit field in a BCD number is a binary representation of a single decimal digit, the rightmost being the one’s place, the second the ten’s, and so on. Thus, the eight-bit accumulator can represent numbers in the range 0 through 99 decimal, and the sixteen-bit accumulator can represent numbers in the range 0 through 9999. Larger decimal numbers can be represented in multiple-precision, using memory variables to store the partial results and the carry flag to link the component fields of the number together, just as multiple-precision binary numbers are.

## The Western Design Center

Decimal mode is set via execution of the **SED** instruction (or a **SEP** instruction with bit three set). This sets the **d** or decimal flag in the status register, causing all future additions and subtractions to be performed in decimal mode until the flag is cleared.

The default mode of the 65x processors is the binary mode with the decimal flag clear. It is important to remember that the decimal flag may accidentally be set by a wild branch, and on the NMOS 6502, it is not cleared on reset. The 65C02, 65802, and 65816 do clear the decimal flag on reset, so this is of slightly less concern. Arithmetic operations intended to be executed in binary mode, such as address calculations, can produce totally unpredictable results if they are accidentally executed in decimal mode.

Finally, although the carry flag is set correctly in the decimal mode allowing unsigned multiple-precision operations, the overflow flag is not, making signed decimal arithmetic, while possible, difficult. You must create your own sign representation and logic for handling arithmetic based on the signs of the operands. Borrowing from the binary two's-complement representation, you could represent negative numbers as those (unsigned) values which, when added to a positive number result in zero if overflow is ignored. For example, 99 would equal  $-1$ , since 1 plus 99 equals 100, or zero within a two-digit precision. 98 would be  $-2$ , and so on. The different nature of decimal representation, however, does not lead itself to signed operation quite as conveniently as does the binary two's-complement form.

# 10) Chapter Ten

## Logic and Bit Manipulation Operations

The logical operations found in this chapter are the very essence of computer processing; even the arithmetic functions, at the lowest level, are implemented as combinations of logic gates. Logic, or more accurately, **boolean logic**, is concerned with the determination of “true” and “false”.

Computers can represent simple logical propositions and relationships as binary states: the bit-value used to represent “1” in a given computer is considered equivalent to true; the bit-value which stands for “0” is considered equivalent to false. This designation is in fact arbitrary, and the values could easily be reversed. What matters is the consistent application of the convention. Alternative terms are “set” and “reset” (or “clear”), “on” and “off,” “high” and “low,” “asserted” and “negated.” There is a tendency to equate all of these terms; this is generally acceptable except when you are concerned with the actual hardware implementation of these values, in which case the issue of positive logic (“on” means “true”) vs. negative logic (“off” means “true”) becomes a consideration. But the intuitive assumption of a positive logic system (“1” equals “on” equals “true”) seems the most natural, and may be considered conventional, so the terms listed above as equivalent will be used interchangeably, as appropriate for a given context.

Before discussing these functions, it is important to remember the bit-numbering scheme described in Chapter 1: bits are numbered right to left from least significant to most significant, starting with zero. So a single byte contains bits zero through seven, and a double byte contains bits zero through fifteen. Bit zero always stands for the “one’s place.” Bit seven stands for the “128ths place” and bit fifteen stands for the “32768ths place,” except that the high bit of a signed number is, instead, the sign bit. A single bit (or string of bits smaller than a byte or double byte) is sometimes called a bit-field, implying that the bits are just a part of a larger data element like a byte or a double byte.

You’ll find two types of instructions discussed in this chapter: the basic logic functions, and the shifts and rotates. They’re listed in Table 10.1.

<i>Mnemonic</i>	<i>Available on:</i>			<i>Description</i>
	<i>6502</i>	<i>65C02</i>	<i>65802/816</i>	
<i>Logic Instruction:</i>				
AND	x	x	x	logical and
EOR	x	x	x	logical exclusive-or
ORA	x	x	x	logical or (inclusive or)
<i>Bit Manipulation Instruction:</i>				
BIT	x	x	x	<i>test bits</i>
TRB		x	x	<i>test and reset bits</i>
TSB		x	x	<i>test and set bits</i>
<i>Shift and Rotate Instructions:</i>				
ASL	x	x	x	<i>shift bits left</i>
LSR	x	x	x	<i>shift bits right</i>
ROL	x	x	x	<i>rotate bits left</i>
ROR	x	x	x	<i>rotate bits right</i>

**Table 10-1 Logic Instructions**

### Logic Functions

The fundamental logical operations implemented on the 65x processor are **and**, **inclusive or**, and **exclusive or**. These are implemented as the **AND**, **ORA**, and **EOR** machine instructions. These three logical operators have two operands, one in the accumulator and the second in memory. All of the addressing modes

## The Western Design Center

available for the **LDA**, **STA**, **ADC**, **SBC**, and **CMP** instructions are also available to the logical operations. The truth tables for these operations are found in Chapter 1 and are repeated again in the descriptions of the individual instructions in Chapter 18.

In addition to these instructions, there are also bit testing instructions that perform logical operations; these are the **BIT** (test memory bits), **TSB** (test and set bits), and **TRB** (test and reset bits) instructions. These three instructions set status flags of memory values based on the result of logical operations, rather than affecting the accumulator.

The logical and bit manipulation instructions are broadly useful: for testing for a condition using boolean logic (for example, *if this is true and that is true then do this*); for **masking** bit fields in a word, forcing them to be on or off; for performing quick, simple multiplication and division functions, such as multiplying by two or taking the modulus of a power of two (finding the remainder of a division by a power of two); for controlling I/O devices; and for a number of other functions.

The most typical usage of the boolean or logical operators is probably where one of the two operands is an immediate value. Immediate values will generally be used in these examples. Additionally, operands will usually be represented in binary form (prefixed by a percent sign - %), since it makes the bit-pattern more obvious. All of the logical operations are performed bitwise; that is, the result is determined by applying the logical operation to each of the respective bits of the operands.

### Logical AND

Consider, for example, the eight-bit **AND** operation illustrated in Figure 10.1.

		bit number									
		7	6	5	4	3	2	1	0		
		0	1	1	1	0	1	1	0		\$76
and		1	1	0	0	1	0	1	1	and	<u>\$CB</u>
		0	1	0	0	0	0	1	0		\$42 result

Figure 10-1 The AND Operation

The result, \$42 or %0100 0010, is formed by **ANDing** bit zero of the first operand with bit zero of the second to form bit zero of the result; bit one with bit one; and so on. In each bit, a one results only if there is a one in the corresponding bit-fields of both the first operand **and** the second operand; otherwise zero results.

An example of the use of the **AND** instruction would be to **mask** bits out of a double-byte word to isolate a character (single-byte) value. A mask is a string of bits, typically a constant, used as an operand to a logic instruction to single out of the second operand a given bit or bit-field by forcing the other bits to zeroes or ones. Masking characters out of double bytes is common in 65802 and 65816 applications where a “default” mode of sixteen-bit accumulator and sixteen-bit index registers has been selected by the programmer, but character data needs to be accessed as well. For some types of character manipulation, it is quicker to simply mask out the extraneous data in the high-order byte than to switch into eight-bit mode. The code in Listing 10.1 is fragmentary in the sense that it is assumed that the core routine is inserted in the middle of other code, with the sixteen-bit accumulator size already selected.

It may seem to be splitting hairs, but this routine, which compares the value in a string of characters pointed to by the value in the memory variable **CHARDEX** to the letter ‘e’ is two machine cycles faster than the alternative approach, which would be to switch the processor into the eight-bit accumulator mode, compare the character, and then switch back into the sixteen-bit mode.

0001	0000			KEEP	KL.10.1	
0002	0000			65816	ON	
0003	0000					
0004	0000		MAIN	START		
0005	0000		PTR	GEQU	\$80	
0006	0000					
0007	0000	18		CLC		
0008	0001	FB		XCE		
0009	0002					
0010	0002	C230		REP	#\$30	assume operation in 16-bit modes
0011	0004			LONGA	ON	
0012	0004			LONGI	ON	
0013	0004					
0014	0004	AC4C00		LDY	CHARDEX	get index pointing to desired char
0015	0007	B91A00	LOOP	LDA	STRING,Y	get the char & the one after it
0016	000A	29FF00		AND	#%000000001111 111	AND out the "next" char
0017	000D	C96500		CMP	#'e'	cmp low byte to 'e', high 0 byte to 0
0018	0010	D004		BNE	NOMATCH	
0019	0012					
0020	0012	38		SEC		return to emulation mode
0021	0013	FB		XCE		
0022	0014					
0023	0014	38		SEC		set carry indicates successful match
0024	0015	60		RTS		
0025	0016					
0026	0016	38	NOMATCH	SEC		return to emulation mode
0027	0017	FB		XCE		
0028	0018					
0029	0018	18		CLC		clear carry indicates unsuccessful match
0030	0019	60		RTS		
0031	001A					
0032	001A	54686573	STRING	DC	C 'These characters'	
0033	002A	61726520		DC	C 'are all packed next to'	
0034	0040	65616368		DC	C 'each other'	
0035	004A	0000		DC	H '0000'	
0036	004C	0000	CHARDEX	DC	2	index to a particular char in STRING
0037	004E			END		

Listing 10.1

Each time the program is executed with a different value for **CHARDEX**, a different adjacent character will also be loaded into the high byte of the accumulator. Suppose the value in **CHARDEX** were four; when the **LDA STRING,Y** instruction is executed, the value in the low byte of the accumulator is \$65, the ASCII value for a lower-case 'e'. The value in the high byte is \$20, the ASCII value for the space character (the space between "These" and "characters"). Even though the low bytes match, a comparison to 'e' would fail, because the high byte of the **CMP** instruction's immediate operand is zero, not \$20 (the assembler having automatically generated a zero as the high byte for the single-character operand 'e').

However, by **ANDing** the value in the accumulator with %0000000011111111 (\$00FF), *no matter what the original value in the accumulator*, the high byte of the accumulator is zeroed (since none of the corresponding bits in the immediate operand are set). Therefore the comparison in this case will succeed, as it will for **CHARDEX** values of 2, 13, 18, 28, 32, 38, and 46, even though their adjacent characters, automatically loaded into the high byte of the accumulator, are different.

The **AND** instruction is also useful in performing certain multiplication and division functions. For example, it may be used to calculate the **modulus** of a power of two. (The modulus operation returns the remainder of an integer division; for example, 13 **mod** 5 equals 3, which is the remainder of 13 divided by 5.) This is done simply by **ANDing** with ones all of the bits to the right of the power of two you wish the modulus

## The Western Design Center

of and masking out the rest. A program fragment illustrating this will be provided later in this chapter, where an example of the use of the **LSR** instruction to perform division by powers of two will also be given.

In general, the **AND** operation is found in two types of applications: selectively turning bits off (byte **AND**ing with zero), and determining if two logical values are both true.

### *Logical OR*

The **ORA** instruction is used to selectively turn bits on by **Or**ing them with ones, and to determine if either (or both) of two logical values is true. A character-manipulation example (Listing 10.2) is used – this time writing a string of characters, the high bit of each of which must be set, to the AppleII screen memory – to demonstrate a typical use of the **ORA** instruction.

Since the video screen is memory-mapped, outputting a string is basically a string move. Since normal Apple video characters must be stored in memory with their high-order bit turned on, however, the **ORA #%10000000** instruction is required to do this if the character string, as in the example, was originally stored in normal ASCII, with the high-order bit turned off. Note that it clearly does no harm to **OR** a character with \$80 (%10000000) even if its high bit is already set, so the output routine does not check characters to see if they need to have set high bit, but rather routinely **Ors** them all with \$80 before writing them to the screen. When each character is first loaded into the eight-bit accumulator from **STRING**, its high bit is off (zero); the **ORA** instruction converts each of the values - \$48, \$65, \$6C, \$6C, \$6F – into the corresponding high-bit-set ASCII values - \$C8, \$E5, \$EC, \$EC, and \$EF, before storing them to screen memory, where they will be displayed as normal, non-inverse characters on the video screen. In this case, the same effect (the setting of the high-order bit) could have been achieved if \$80 had been added to each of the characters instead; however, the **OR** operation differs from addition in that even if the high bit of the character already had a value of one, the result would still be one, rather than zero plus a carry as would be the case if addition were used. (Further a **CLC** operation would also have been required prior to the addition, making **ORA** a more efficient choice as well.)

## The Western Design Center

0001	0000			KEEP	KL.10.2	
0002	0000			65816	ON	
0003	0000					
0004	0000		L102	START		
0005	0000			MSB	OFF	
0006	0000		SCREEN	GEQU	\$400	start of AppleII screen memory
0007	0000					
0008	0000	18		CLC		
0009	0001	FB		XCE		
0010	0002					
0011	0002	C210		REP	#\$10	16-bit index register
0012	0004			LONGI	ON	
0013	0004					
0014	0004	E220		SEP	#\$20	8-bit accum
0015	0006			LONGA	OFF	
0016	0006					
0017	0006	A00000		LDY	#0	starting index into string & screen = 0
0018	0009					
0019	0009	B91900	TOP	LDA	STRING,Y	get char from string
0020	000C	F008		BEQ	DONE	branch if at 0 terminator
0021	000E	0980		ORA	##10000000	set the high bit
0022	0010	990004		STA	SCREEN,Y	store the char into screen memory
0023	0013					
0024	0013	C8		INY		
0025	0014	80F3		BRA	TOP	
0026	0016					
0027	0016	38	DONE	SEC		
0028	0017	FB		XCE		
0029	0018	60		RTS		
0030	0019					
0031	0019	48656C6C	STRING	DC	C 'Hello'	
0032	001E	00		DC	H '00'	
0033	001F					
0034	001F			END		

Listing 10.2

### Logical Exclusive-Or

The third logical operation, **Exclusive-OR**, is used to invert bits. Just as inclusive-OR (**ORA**) will yield a true result if either or both of the operands are true, exclusive-or yields true only if one operand is true and the other is false; if both are true or both are false, the result is false. This means that by setting a bit in the memory operand of an **EOR** instruction, you can invert the corresponding bit of the accumulator operand (where the result is stored). In the preceding example, where the character constants were stored with their high bits off, an **EOR #80** instruction would have had the same effect as **ORA #80**; but like addition, if some of the characters to be converted already had their high-order bits set, the **EOR** operation would clear them.

Two good examples of the application of the **EOR** operation apply to signed arithmetic. Consider the multiplication of two signed numbers. As you know, the sign of the product is determined by the signs of the multiplier and multiplicand according to the following rule: if both operands have the same sign, either positive or negative, the result is always positive; if the two operands have different signs, the result is always negative. You perform signed multiplication by determining the sign of the result, and then multiplying the absolute values of both operands using the same technique as for unsigned arithmetic. Finally, you consider the sign of the result: if it is positive, your unsigned result is the final result; if it is negative, you form the final result by taking the two's-complement of the unsigned result. Because the actual multiplication code is not included, this example is given as two fragments, 10.1 and 10.2.

Fragment 10.1 begins by clearing the memory location **SIGN**, which will be used to store the sign of the result. Then the two values to be multiplied are exclusive-OR'd, and the sign of the result is tested with the

## The Western Design Center

**BPL** instruction. If the sign bit of the result is negative, you know that the sign bits of the two operands were different, and therefore the result will be negative; a negative result is preserved by decrementing the variable **SIGN**, making its value \$FFFF.

Next, the two operands are converted to their absolute values by two's complementing them if they are negative. The technique for forming the two's complement of a number is to invert it, and then add one. The **EOR** operation is used again to perform the inversion; the instruction **EOR #\$FFFF** will invert all of the bits in the accumulator: ones become zeroes, and zeros become ones. An **INC A** instruction adds one. In the case of **NUM2**, this result must be saved to memory before the accumulator is reloaded with **NUM1**, which is also two's complemented if negative.

0000	0000	NUM1	DS	2	
0002	0000	NUM2	DS	2	
0004					
0004	C230		REP	#\$30	16-bit modes
0006			LONGA	ON	
0006			LONGI	ON	
0006					
0006	9C0080		STZ	SIGN	clear the sign
0009	AD0000		LDA	NUM1	
000C	4D0200		EOR	NUM2	exclusive-or: check sign
000F	1003		BPL	OK	
0011	CE0080		DEC	SIGN	negative: sign = \$FFFF
0014	AD0200	OK	LDA	NUM2	
0017	1007		BPL	OK1	
0019	49FFFF		EOR	#\$FFFF	minus: get absolute value
001C	1A		INC	A	
001D	8D0200		STA	NUM2	
0020	AD0000	OK1	LDA	NUM1	
0023	1004		BPL	OK2	
0025	49FFFF		EOR	#\$FFFF	
0028	1A		INC	A	
0029		OK2	ANOP		

**Fragment 10.1**

At this point, the unsigned multiplication of the accumulator and **NUM2** can be performed. The code for the multiplication itself is omitted from these fragments; however, an example of unsigned multiplication is found in Chapter 14. The important fact for the moment is that the multiplication code is assumed to return the unsigned product in the accumulator.

0000	AE0080		LDX	SIGN	
0003	1004		BPL	DONE	
0005	49FFFF		EOR	#\$FFFF	if should be neg,
0008	1A		INC	A	two's complement the result
0009	60	DONE	RTS		
000A					

**Fragment 10.2**



What remains is to adjust the sign of the result; this code is found in Fragment 10.2. By testing the sign of **SIGN**, it can be determined whether or not the result is negative; if it is negative, the actual result is the two's complement of the unsigned product, which is formed as described above.

### Bit Manipulation

You have now been introduced to the three principal logical operators, **AND**, **ORA**, and **EOR**. In addition there are three more specialized bit-manipulating instructions that use the same logical operations.

The first of these is the **BIT** instruction. The **BIT** instruction really performs two distinct operations. First, it directly transfers the highest and next to highest bits of the memory operand (that is, seven and six if **m** = 1, or fifteen and fourteen if **m** = 0) to the **n** and **v** flags. It does this without modifying the value in the accumulator, making it useful for testing the sign of a value in memory without loading it into one of the registers. An exception to this is the case where the immediate addressing mode is used with the **BIT** instruction: since it serves no purpose to test the bits of a constant value, the **n** and **v** flags are left unchanged in this one case.

**BIT**'s second operation is to logically AND the value of the memory operand with the value in the accumulator, conditioning the **z** flag in the status register to reflect whether or not the result of the ANDing was zero or not, but *without* storing the result in the accumulator (as is the case with the **AND** instruction) or saving the result in any other way. This provides the ability to test if a given bit (or one or more bits in a bit-field) is set by first loading the accumulator with a mask of the desired bit patterns, and then performing the **BIT** operation. The result will be non-zero only if at least one of the bits set in the accumulator is likewise set in the memory operand. Actually, you can write your programs to use either operand as the mask to test the other, except when immediate addressing is used, in which case the immediate operand is the mask, and the value in the accumulator is tested.

A problem that remained from the previous chapter was **sign extension**, which is necessary when mixed-precision arithmetic is performed – that is, when the operands are of different sizes. It might also be used when converting to a higher precision due to overflow. The most typical example of this is the addition (or subtraction) of a signed eight-bit and a signed sixteen-bit value. In order for the lesser-precision number to be converted to a signed number of the same precision as the larger number, it must be **sign-extended** first, by setting or clearing all of the high-order bits of the expanded-precision number to the same value as the sign bit of the original, lesser-precision number.

In other words, \$7F would become \$007F when sign-extended to sixteen bits, while \$8F would become \$FF8F. A sign-extended number evaluates to the same number as its lesser precision form. For example, \$FF and \$FFFF both evaluate to -1.

You can use the **BIT** instruction to determine if the high-order bit of the low-order byte of the accumulator is set, even while in the sixteen-bit accumulator mode. This is used to sign extend an eight-bit value in the accumulator to a sixteen-bit one in Listing 10.3.

0001	0000		KEEP	KL.10.3		
0002	0000		65816	ON		
0003	0000					
0004	0000	L103	START			
0005	0000	18	CLC			
0006	0001	FB	XCE			
0007	0002					
0008	0002	C230	REP	#\$30	turn 16-bit modes on	
0009	0004		LONGA	ON		
0010	0004		LONGI	ON		
0011	0004					
0012	0004	A500	LDA	0	get value to sign extend	
0013	0006					
0014	0006	29FF00	AND	#\$FF	zero out any garbage in high byte	
0015	0009	898000	BIT	#\$80	test high bit of low byte	
0016	000C	F003	BEQ	OK	number is positive; leave as is	
0017	000E	0900FF	ORA	#\$FF00	turn on high bits	
0018	0011					
0019	0011	8500	OK	STA	0	save sign-extended value
0020	0013					
0021	0013	38	SEC			
0022	0014	FB	XCE			
0023	0015	60	RTS			
0024	0016		END			

Listing 10.3

The pair of “test-and-set” instructions, **TSB** and **TRB**, are similar to the **BIT** instruction in that they set the zero flag to represent the result of ANDing the two operands. They are dissimilar in that they do not affect the **n** and **v** flags. Importantly, they also set (in the case of **TSB**) or reset (in the case of **TRB**) the bits of the memory operand according to the bits that are set in the accumulator (the accumulator value is a mask). You should recognize that the mechanics of this involve the logical functions described above: the **TSB** instruction Ors the accumulator with the memory operand, and stores the result to memory; the **TRB** inverts the value in the accumulator, and then ANDs it with the memory operand. Unlike the **BIT** instruction, both of the test-and-set operations are read-modify-write instructions; that is, in addition to performing an operation on the memory value specified in the operand field of the instruction, they also store a result to the same location.

The test-and-set instructions are highly specialized instructions intended primarily for control of memory-mapped I/O devices. This is evidenced by the availability of only two addressing modes, direct and absolute, for these instructions; this is sufficient when dealing with memory-mapped I/O, since I/O devices are always found at fixed memory locations.

## Shifts and Rotates

The second class of bit-manipulating instructions to be presented in this chapter are the shift and rotate instructions: **ASL**, **LSR**, **ROL**, and **ROR**. These instructions copy each bit value of a given word into the adjacent bit to the “left” or “right.” A shift to the left means that the bits are shifted into the next-higher-order bit; a shift to the right means that each is shifted into the next-lower-order bit. The bit shifted out of the end—that is, the original high-order bit for a left shift, or the original low order bit for a right shift—is copied into the carry flag.

Shift and rotate instructions differ in the value chosen for the origin bit of the shift or rotate. The shift instructions write a zero into the origin bit of the shift – the low-order bit for a shift left of the high-order bit for shift right. The rotates, on the other hand, copy the original value of the carry flag into the origin bit of the shift. Figure 10.2. and Figure 10.3 illustrate the operation of the shift and rotate instructions.

The carry flag, as Fragment 10.3 illustrates, is used by the combination of a shift followed by one or more rotate instructions to allow multiple-precision shifts, much as it is used by **ADC** and **SBC** instructions to enable multiple-precision arithmetic operations.

## The Western Design Center

In this code fragment, the high-order bit in **LOC1** is shifted into the carry flag in the first **ASL** instruction and a zero is shifted into the low-order bit of **LOC1**; its binary value changes from

10101010101010

to

01010101010100    carry = 1

The next instruction, **ROL**, shifts the value in the carry flag (the old high bit of **LOC1**) into the low bit of **LOC2**. The high bit of **LOC2** is shifted into the carry.

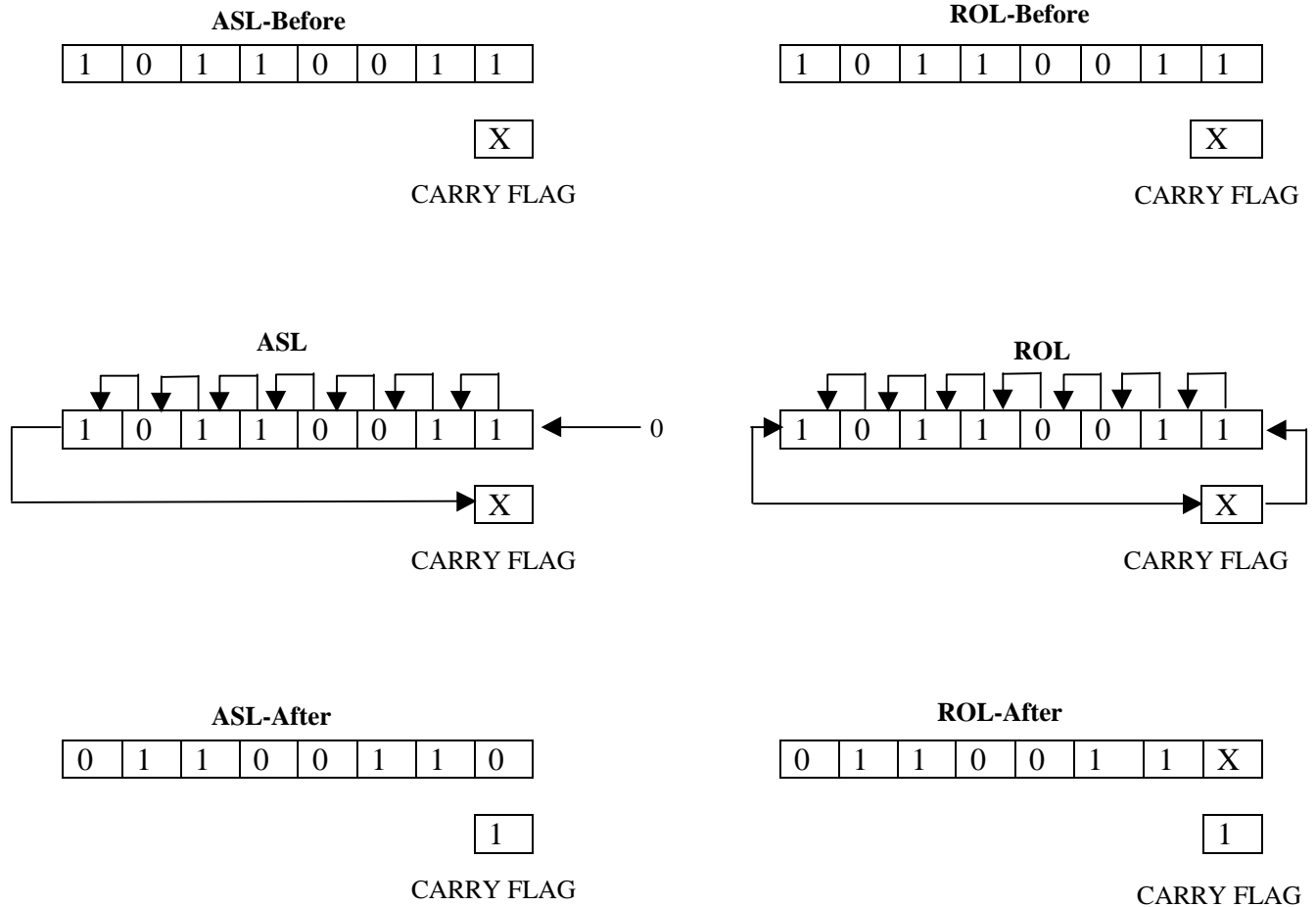

Figure 10-2 Shift and Rotate Left

0000	A9AAAA	LDA	##%1010101010101010
0003	8D0080	STA	LOC1
0006	A9AAAA	LDA	##%1010101010101010
0009	8D0080	STA	LOC2
000C	0E0080	ASL	LOC1
000F	2E0080	ROL	LOC2

Fragment 10.3

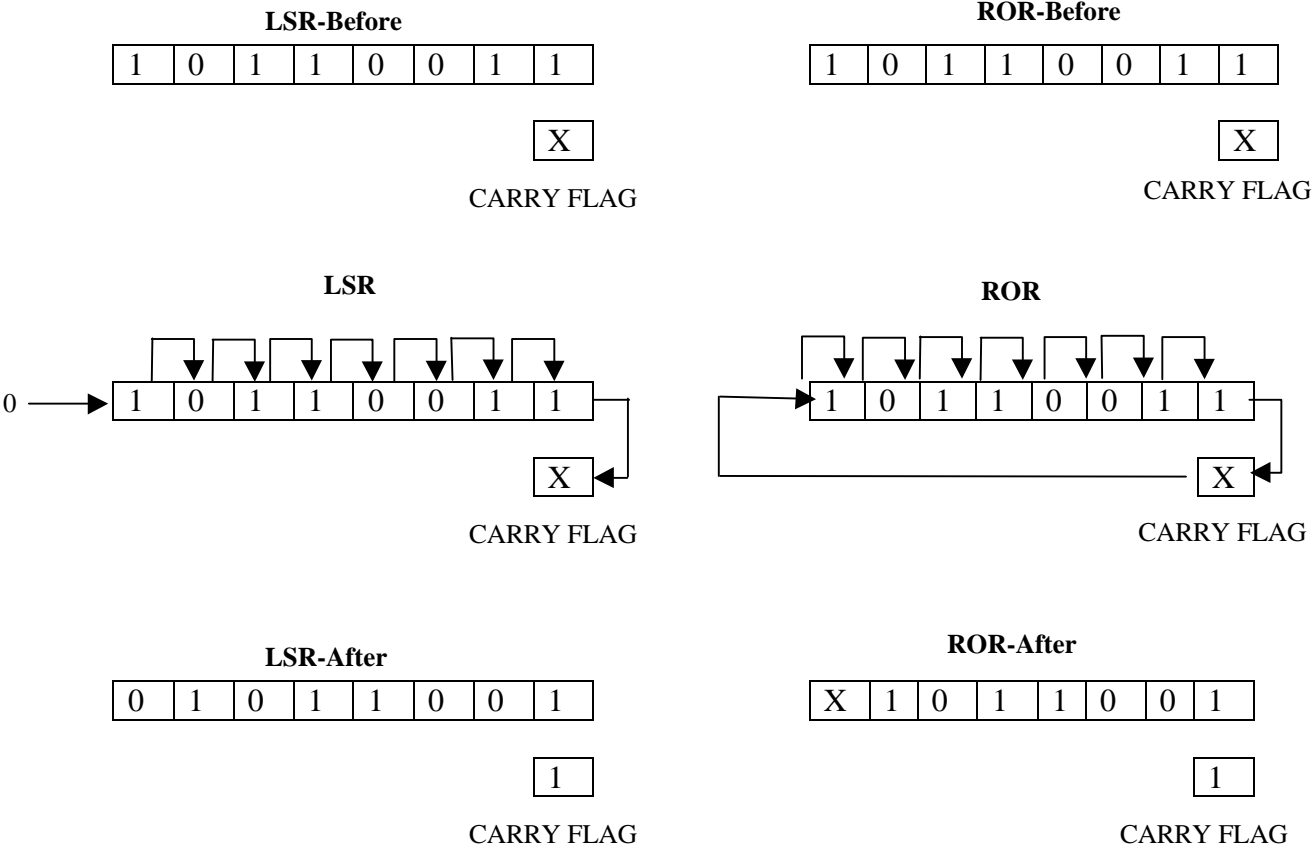

Figure 10-3 Shift and Rotate Right

## The Western Design Center

1010101010101010

becomes

0101010101010101      carry = 1

A double-precision shift left has been performed.

What is the application of the shift and rotate instructions? There are two distinct categories: multiplication and division by powers of two, and generalized bit-manipulation.

Left shifts multiply the original value by two. Right shifts divided the original value by two. This principal is inherent in the concept of positional notation; when you multiply a value by ten by adding a zero to the end of it, you are in effect shifting it left one position; likewise when you divide by ten by taking away the right-most digit, which in this case is base two.

Shifting is also useful, for the same reason, in a generalized multiply routine, where a combination of shift and add operations are performed iteratively to accomplish the multiplication. Sometimes, however, it is useful to have a dedicated multiplication routine, as when a quick multiplication by a constant value is needed. If the constant value is a power of two – such as four, the constant multiplier in Fragment 10.4 – the solution is simple: shift left a number of times equal to the constant's power of two (four is two to the power, so two left shifts are equivalent to multiplying by four).

0000	A93423	LDA	#\$2334	
0003	0A	ASL	A	times 4 (2 to the 2 <sup>nd</sup> power)
0004	0A	ASL	A	

### Fragment 10.4

The result in the accumulator is \$2334 times four, or \$8CD0. Other “quickie” multiply routines can be easily devised for multiplication by constants that are not a power of two. Fragment 10.5 illustrates multiplication by ten: the problem is reduced to a multiplication by eight plus a multiplication by two.

0000	A9D204	LDA	#1234	
0003	0A	ASL	A	multiply by 2
0004	8D0080	STA	TEMP	save intermediate result
0007	0A	ASL	A	times 2 again = times 4
0008	0A	ASL	A	times 2 again = times 8
0009	18	CLC		
000A	6D0080	ADC	TEMP	= times 10

### Fragment 10.5

After the first shift left, which multiplies the original value by two, the intermediate result ( $1234 * 2 = 2468$ ) is stored at location **TEMP**. Two more shifts are applied to the value in the accumulator, which equals 9872 at the end of the third shift. This is added to the intermediate result of 1234 times 2, which was earlier stored at location **TEMP**, to give the result 12,340, or  $1234 * 10$ .

Division using the shift right instructions is similar. Since bits are lost during a shift right operation, just as there is often a remainder when an integer division is performed, it would be useful if there were an easy way to calculate the remainder (or modulus) of a division by a power of two. This is where the use of the **AND** instruction alluded to earlier comes into play.

0000	A91FE2	LDA	#\$E21F	
0003	48	PHA		save accumulator
0004	4A	LSR	A	divide by 2
0005	4A	LSR	A	divide by 2 again = divide
0006	8D0080	STA	QUO	save quotient
0009	68	PLA		recover original value
000A	290300	AND	#\$3	
000D	8D0080	STA	MOD	save modulus

**Fragment 10.6**

Consider Fragment 10.6. In this case, \$E21F is to be divided by four. As with multiplication, so with division: two shifts are applied, one for each power of two, this time to the right. By the end of the second shift, the value in the accumulator is \$3887, which is the correct answer. However, two bits have been shifted off to the right. The original value in the accumulator is recovered from the stack and then ANDed with the divisor minus one, or three. This masks out all but the bits that are shifted out during division by four, the bits which correspond to the remainder or modulus the quotient times four, and then adding the remainder.

The second use for the shift instructions is general bit manipulation. Since the bit shifted out of the word always ends up in the carry flag, this is an easy way to quickly test the value of the high- or low-order bit of a word. Listing 10.4 gives a particularly useful example: a short routine to display the value of each of the flags in the status register. This routine will, one by one, print the letter-name of each of the status register flags if the flag is set (as tested by the **BCS** instruction), or else print a dash if it is clear.

The Western Design Center

0001	0000		KEEP	KL.10.4		
0002	0000		65816	ON		
0003	0000					
0004	0000					
0005	0000		PRINTP	START		
0006	0000		PREG	GEQU	\$80	
0007	0000		PTR	GEQU	\$82	
0008	0000					
0009	0000					
0010	0000	08		PHP		save (on the stack)
0011	0001		;			the status reg to be displayed
0012	0001					
0013	0001	18		CLC		
0014	0002	FB		XCE		
0015	0003					
0016	0003	C2FF		REP	#\$FF	16-bit index regs; reset all flags
0017	0005	E220		SEP	#\$20	8-bit accum
0018	0007			LONGI	ON	
0019	0007			LONGA	OFF	
0020	0007					
0021	0007	68		PLA		pull status reg to display into accum
0022	0008	8580		STA	PREG	then store to memory location PREG
0023	000A	A23000		LDX	#FLAGS	load 16-bit X with ptr to flag string
0024	000D	8682		STX	PTR	and store to PTR
0025	000F	A20800		LDX	#8	load X with counter (# of flag bits)
0026	0012					
0027	0012	0680	LOOP	ASL	PREG	shift high bit of PREG → carry
0028	0014	B004		BCS	DOFLAG	branch if set
0029	0016	A92D		LDA	#'-'	if flag not set, output '-'
0030	0018	8002		BRA	SKIP	
0031	001A	B282	DOFLAG	LDA	(PTR)	get flag letter from FLAGS
0032	001C	200080	SKIP	JSR	COUT	output flag letter or '-'
0033	001F	E682		INC	PTR	16-bit
0034	0021	D002		BNE	OK	increment
0035	0023	E683		INC	PTR+1	(incr hi byte if low rolls over)
0036	0025	CA	OK	DEX		decrement counter
0037	0026	DOEA		BNE	LOOP	continue thru all 8 bits of status reg
0038	0028	A90D		LDA	#\$0D	output cr after all 8 flags
0039	002A	200080		JSR	COUT	
0040	002D					
0041	002D	38		SEC		
0042	002E	FB		XCE		
0043	002F	60		RTS		
0044	0030					
0045	0030	6E766D78	FLAGS	DC	c'nvmxdizc'	
0046	0038					
0047	0038			END		
SKIP		00001C				
0048	0000					
0049	0000					
0050	0000		COUT	START		
0051	0000		ECOUT	GEQU	\$FDED	COUT IN APPLE I I MONITOR
0052	0000	48		PHA		



**The Western Design Center**

0053	0001	DA	PHX	
0054	0002	5A	PHY	
0055	0003	08	PHP	
0056	0004	38	SEC	
0057	0005	FB	XCE	
0058	0006	20EDFD	JSR	ECOUT
0059	0009	18	CLC	
0060	000A	FB	XCE	
0061	000B	28	PLP	
0062	000C	7A	PLY	
0063	000D	FA	PLX	
0064	000E	68	PLA	
0065	000F	60	RTS	
0066	0010		END	

**Listing 10.4**

# 11) Chapter Eleven

## The Complex Addressing Modes

Chapter 7 defined the term **addressing mode** and introduced the set of simple 65x addressing modes, those which involve at most a minimum of calculating combined values from multiple locations.

This chapter continues and expands the discussion of one of those modes, the direct page addressing mode, for those cases where the direct page register value is other than zero. It discusses the basis for selection by the assembler among the direct page, absolute, and long addressing modes, and how you can explicitly override those assumptions. And it discusses the set of complex addressing modes available on the 6502, the 65C02, the 65802, and the 65816, those which require the effective address to be calculated from several sources (Table 11.1). The understanding of these modes also provides the context within which to discuss several more complex push instructions that were previously deferred to this chapter (Table 11.2).

<i>Available on all 65x processors:</i>	<i>Example</i>	<i>Syntax</i>
absolute indexed with X	LDA	\$2234,X
absolute indexed with Y	LDA	\$2234,Y
direct page (zero page) indexed with X	LDA	\$17,X
direct page (zero page) indexed with Y	LDX	\$17,Y
direct page (zero page) indirect indexed with Y	LDA	(\$17),Y
direct page (zero page) indexed indirect with X	LDA	(\$17,X)
<hr/>		
<i>Available on the 65C02, 65802, and 65816 only:</i>		
absolute indexed indirect	JMP	(\$ 7821,X)
<hr/>		
<i>Available on the 6502 and 65816 only:</i>		
non-zero direct page	LDA	\$17
absolute long indexed with X	LDA	\$654321,X
direct page indirect long indexed with Y	LDA	[\$17],Y
stack relative	LDA	\$29,S
stack relative indirect indexed with Y	LDA	(\$29,S),Y

**Table 11-1 Complex Addressing Modes**

Mnemonic	<i>Available on:</i>			<i>Description</i>
	<i>6502</i>	<i>65C02</i>	<i>65802/816</i>	
PEA			x	push effective absolute address
PEI			x	push effective indirect address
PER			x	push effective relative address

**Table 11-2 Complex Push Instructions**

## Relocating the Direct Page

Chapter 7 discussed zero page addressing as found on the 6502 and 65C02 and introduced direct page addressing, the 65816's enhancement to zero page addressing. The 65816 lets the zero page addressing modes use a direct page that can be located and relocated anywhere in the first 64K of memory. But Chapter 7 left the direct page set to page zero so it could be discussed as a simple addressing mode – that is, so no calculation of direct page register base plus direct page offset needed to be done and so the operand, a direct page offset, could be thought of as an absolute address with a high-order byte of zero.

Relocating the direct page from page zero, to which it is initialized on power-up, can be accomplished in either of two ways. The first would let a new value be pulled off the stack into the direct page register with the **PLD** instruction, as found in Fragment 11.1.

0000		;		set direct page register to \$3400
0000	A20034		LDX	#\$3400
0003	DA		PHX	and push it onto the stack,
0004	2B		PLD	then pull it into direct page reg

**Fragment 11.1**

Fragment 11.2 illustrates the second method. The direct page register can be set to the value in the sixteen-bit **C** accumulator by use of the **TCD** instruction, which transfers sixteen bits from accumulator to direct page register.

0000		;		set direct page register to \$FE00
0000	A900FE		LDA	#\$FE00
0003	5B		TCD	and transfer from C accum into direct pg

**Fragment 11.2**

Both methods of setting the direct page register give it a sixteen-bit value. Since sixteen bits are only capable of specifying an address within a 64K range, its bank component must be provided in another manner; this has been done by limiting the direct page to bank zero. The direct page can be located anywhere in 64K but the bank address of the direct page is always bank zero.

Chapter 7, which limited the use of the direct page to page zero, used the example shown in Fragment 11.3 to store the one-byte value \$F0 at address \$0012, which is the direct page offset of \$12 added to a direct page register value of zero. If instead the direct page register is set to \$FE00, then \$F0 is stored to \$FE12; the direct page offset of \$12 is added to the direct page register value of \$FE00.

0000	A9F0000		LDA	#\$F0
0003	8512		STA	\$12
				store accumulator to dp:\$12

**Fragment 11.3**

While it is common to speak of a **direct page address** of \$12, \$12 is really an *offset* from the base value in the direct page register (\$FE00 in the last example). The two values are added to form the **effective direct page address** of \$FE12.

But while Chapter 7 defined a **page** of memory as \$100 locations starting from a page boundary (any multiple of \$100), the direct page does not have to start on a page boundary; the direct page register can hold *any* sixteen-bit value. If the code in Fragment 11.4 is executed, running the code in Fragment 11.3 stores the one-byte value \$f0 at address \$1025: \$1013 plus \$12.

## The Western Design Center

0000		;		set direct page register to \$1013	
0000	A91310		LDA	#\$1013	get \$1013 into sixteen-bit accum
0003	5B		TCD		transfer \$1013 from C into direct pg reg

### Fragment 11.4

You will for the most part, however, want to set the direct page to begin on a boundary: it saves one cycle for every direct page addressing operation. This is because the processor design includes logic that, when the direct page register's low byte is zero, concatenates the direct page register's high byte to the direct page offset – instead of adding the offset to the entire direct page register – to form the effective direct page address; concatenation saves a cycle over addition.

One of the benefits of the direct page concept is that programs, and even parts of programs, can have their own \$100-byte direct pages of variable space separate from the operating system's direct page of variable space. A routine might set up its own direct page with the code in Fragment 11.5.

0000		;		set up direct page for this routine at \$0300	
0000	0B		PHD		first save current direct page location
0001	A90003		LDA	#\$300	load sixteen-bit accumulator with \$300
0004	5B		TCD		transfer \$300 into direct page reg

### Fragment 11.5

To end the routine and restore the direct page register to its previous value, simply execute a **PLD** instruction.

As discussed in Chapter 7, having a direct page makes accessing zero page addresses in any bank require special assembler syntax. Since the zero page is no longer special, absolute addressing must be used; but since the assembler normally selects direct page addressing for operands less than \$100, the standard syntax requires that you prefix a vertical bar or exclamation point to the operand to force the assembler to use absolute addressing. This is just one of the potential assembler misassumptions covered in the next section.

## Assembler Addressing Mode Assumptions

When the assembler encounters an address in the operand field of an instruction, it must decide whether the address is a direct page offset, a sixteen-bit absolute address, or a 24-bit long address and generate opcode and operand values which are appropriate. Its decision is based on the operand's size – not the number of digits in the operand, but whether the value of the operand is greater than \$FF or greater than \$FFFF. For example, the assembler will interpret the operand \$3F to be a direct page offset regardless of whether it is written as \$3F, \$003F, or \$00003F, because its value is less than 100 hex.

As a result, there are several areas of memory in 65802 and 65816 systems that the assembler will not access without entering the special syntax shown in Table 11.3 to override the assembler's assumptions.

<i>Syntax</i>	<i>Description</i>
<i>8-bit operand (less than \$100):</i>	
<i>Normal direct page addressing:</i>	
LDA \$32	load accum from: bank zero: direct page: \$32
<i>Force absolute addressing: zero page in data bank:</i>	
LDA !\$32	load accum from: data bank: \$0032
<i>Force long addressing: zero page in bank zero:</i>	
LDA >\$32	load accum from: \$00:0032
<i>16-bit operand (from \$100 through \$FFFF):</i>	
<i>Normal absolute addressing:</i>	
LDA \$7512	load accum from: data bank: \$7512
<i>Force direct page addressing:</i>	
LDA <47512	load accum from: bank zero: direct page: \$12
<i>Force long addressing:</i>	
LDA >\$7512	load accum from: \$00:7512
<i>24-bit operand (over \$FFFF):</i>	
<i>Normal long addressing:</i>	
LDA \$123456	load accum from: \$12:3456
<i>Force absolute addressing:</i>	
LDA !\$123456	load accum from: data bank: \$3456
<i>Force direct page addressing:</i>	
LDA <\$123456	load accum from: bank zero: direct page: \$56

**Table 11-3 Assembler Syntax for Complete Memory Access**

The first is zero page memory. Page zero has no special meaning in the 65802 and 65816: its special attributes have been usurped by the direct page, so accessing it requires use of absolute addressing just like any other absolute location. But the assembler assumes addresses less than \$100 are direct page *offsets*, not zero page *addresses*; it will not generate code to access the zero page (unless the direct page is set to the zero page so that the two are one and the same) without explicit direction. And even if the direct page is set to the zero page, 65816 systems have a zero page not only in bank zero but also in every other bank, and those other page zeroes cannot ever be accessed by absolute addressing without special direction.

The syntax to force the assembler to use absolute addressing is to precede an operand with a vertical bar or exclamation point as shown in Fragment 11.6.

0000	C220	REP	#\$20	set accumulator/memory to sixteen
0002		LONGA	ON	
0002	A90032	LDA	#\$3200	get new direct page location
0005	5B	TCD		and set up direct page at \$3200
0006	E210	SEP	#\$10	set index registers to eight-bit
0008		LONGI	OFF	
0008	A202	LDX	#2	set new data location to bank 2
000A	DA	PHX		push 2 on stack
000B	AB	PLB		and pull it off into data bank
000C	A532	LDA	\$32	load accumulator from dp:\$32 in bank 0
000E	8D3200	STA	!\$32	store accum at \$02:0032 (data bank)
0011	8F320000	STA	>\$32	store accum at \$00:0032 (long address)

**Fragment 11.6**

Notice the use of another symbol, the greater-than sign (>), to force long addressing. This solves another problem: The assembler assumes absolute addresses are in the data bank; if the value in the data bank is other than zero, then it similarly will not generate code to access bank zero without special direction. The greater-than sign forces the assembler to use a long addressing mode, concatenating zero high bits onto the operand until it's 24 bits in length. This usage is shown in Fragment 11.7, where the greater-than sign forces absolute long addressing, resulting in the assembler generating an opcode using absolute long addressing to store the accumulator, followed by the three absolute long address bytes for \$00:0127, which are, in 65x order, \$27, then \$01, then \$00.

The **ASL** instruction in Fragment 11.7 makes use of the third assembler override syntax: prefixing an operand with the less-than sign (<) forces direct page addressing. It's not likely you'll use this last syntax often, but it may come in handy when you've assigned a label to a value that you need the assembler to truncate to its low-order eight bits so it will be used as a direct page offset.

Note that this override syntax is the recommended standard syntax. As Chapter 1 (Basic Concepts) points out, even mnemonics can vary from one assembler to another, so assembler syntax such as this can differ as well.

0000	E210	SEP	#\$10	use 8 bit index registers
0002		LONGI	OFF	
0002				
0002	A202	LDX	#2	get new data bank value
0004	DA	PHX		push it on stack
0005	AB	PLB		pull into data bank
0006	AD2701	LDA	\$127	from B:\$0127 (\$02:0127)
0009	8F270100	STA	>\$127	store at \$00:0127
000D	0627	ASL	<\$127	shift word at dp:\$27

**Fragment 11.7**

## Direct Page Indirect Indexed With Y Addressing

**Direct page indirect indexed addressing** or **postindexing**, which uses the **Y** register, is one of two ways indirect addressing can be combined with indexing (the other will be described in the next section). In postindexing, the processor goes to the location the direct page operand specifies and adds the index to the indirect address found there.

Like direct page addressing, which was discussed in Chapter 7 (The Simple Addressing Modes), postindexing gives you the freedom to access a memory location which is not determined until the program is executing. As you also learned from Chapter 7, direct page indirect lets your program store the absolute address of a data bank location you want to access (this address is called the indirect address) into any two consecutive bytes in the direct page. This makes those two bytes perform as though they are an extra sixteen-bit register in the microprocessor itself. Further, it leaves the processor's registers unobstructed, and it allows data at the location stored in the direct page "register" to be accessed at any time.

## The Western Design Center

Postindexing differs in that the absolute address you store into the direct page “register” is not one location but the base of an array; you can then access a particular byte in the array by loading its array index into the **Y** register and specifying, as your operand, the direct page “register” (the location of the indirect base of the array). As Figure 11.1 shows, the processor goes to the direct page offset, gets the absolute memory location there, then adds the contents of the **Y** register to get the absolute memory location it will access. The direct page offset, being in the direct page, is in bank zero on the 65816; the array, on the other hand, is in the data bank.

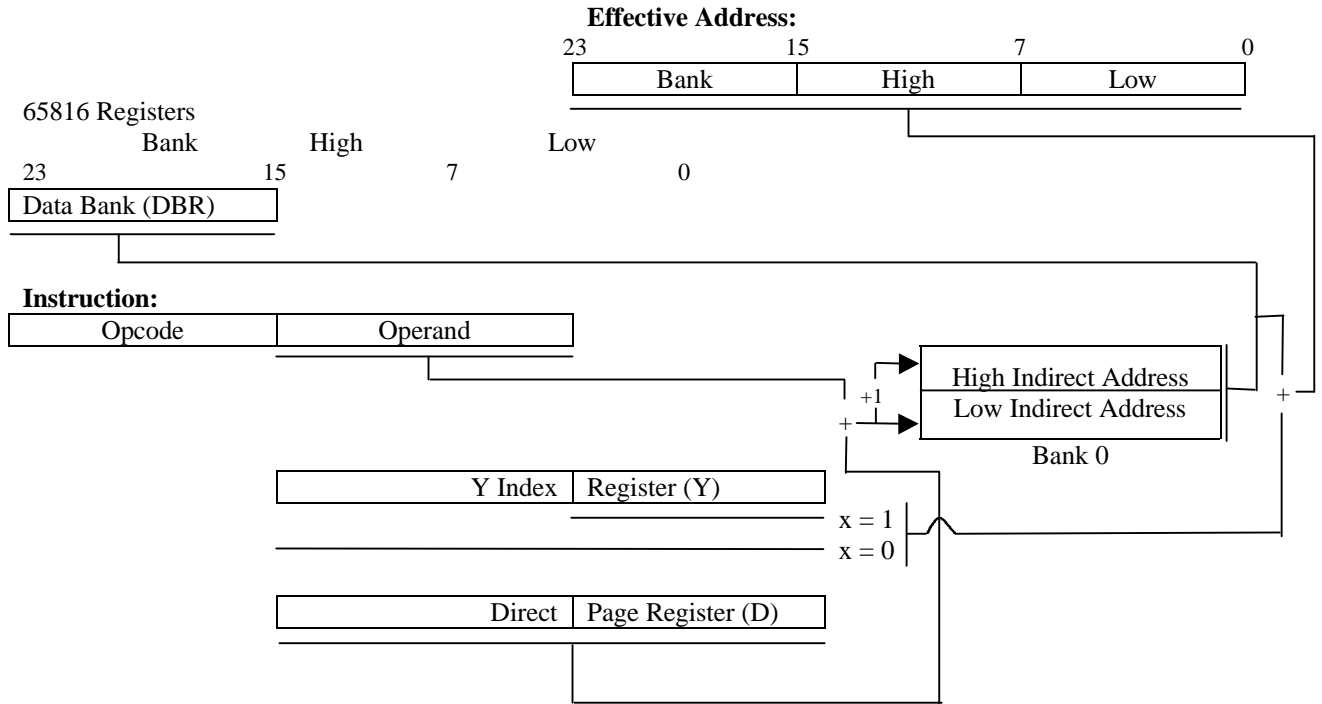

Figure 11-1 Postindexing

This addressing mode is called postindexing because the **Y** index register is added *after* the indirect address is retrieved from the direct page.

For example, suppose that your program needs to write a dash (hyphen) character to a location on the AppleII’s 40-column screen that will be determined while the program is running. Further suppose your program picks a screen location at column nine on line seven. The AppleII has a firmware routine (called **BASCALC**) which, when presented with the number of a line on the screen, calculates the address of the leftmost position in the line and returns it in zero page location **BASL**, located at memory locations \$0028 and \$00029.

If you wanted to write your hyphen to the *first* position on the line, you could, after calling **BASCALC** and loading the character to print into the accumulator, use the 65C02’s indirect addressing mode:

```
9228          STA          (BASL)
```

The 6502 has no simple indirect addressing mode, but Fragment 11.8 illustrates what 6502 programmers long ago learned: you can use postindexing to the same effect as simple indirect by loading the **Y** register with zero.

## The Western Design Center

0000		BASL	EQU	\$28	
0000	A92D		LDA	#'-'	write a dash
0002	A000		LDY	#0	
0004	9128		STA	(BASL),Y	to (BASL)
0006			.		
0006			.		
0006			.		

### Fragment 11.8

But you want to write the hyphen character to column nine (the leftmost position being column zero), not column zero. After calling **BASCALC**, you load the **Y** register with nine and write your character indirect through **BASL** indexed by the nine in **Y** as seen in Fragment 11.9. If **BASCALC** calculates line seven on the screen to start at location \$780, and as a result stores that address at **BASL**, then the routine in Fragment 11.9 will write a dash to location \$789 (column nine on line seven).

0000	A92D		LDA	#'-'	write a dash
0002	A009		LDY	#9	to col 9
0004	9128		STA	(BASL),Y	on the line with its base i

### Fragment 11.9

You could write a line of dashes from column nine through column sixteen simply by creating the loop coded in Listing 11.1. This kind of routine has been used for years on the 6502-based AppleII .

0001	0000		KEEP	KL.11.1	
0002	0000		65816	OFF	
0003	0000		;	6502	example
0004	0000				
0005	0000		L111	START	
0006	0000				
0007	0000		BASL	GEQU	\$28
0008	0000		LINE7	GEQU	\$780
0009	0000				
0010	0000	A980	LDA	#LINE7	
0011	0002	8528	STA	BASL	
0012	0004	A907	LDA	#>LINE7	
0013	0006	8529	STA	BASL+1	
0014	0008	A92D	LDA	#'-'	write a dash
0015	000A	A009	LDY	#9	to col 9
0016	000C	9128	LOOP	STA	(BASL),Y on the line with its base in BASL
0017	000E	C8	INY		incr pointer to next column position
0018	000F	C011	CPY	#17	
0019	0011	90F9	BCC	LOOP	(BLT): write another dash up to col. 17
0020	0013	60	RTS		
0021	0014				
0022	0014		END		

### Listing 11.1

Finally, note that, like absolute indexed addressing, the array of memory accessible to the indirect indexed addressing mode can extend beyond the current 64K data bank into the next 64K bank, if the index plus the array base exceeds \$FFFF.



## Direct Page Indexing Indirect Addressing

As the introduction to the last section pointed out, you can combine indexing with indirection in two ways. Postindexing, discussed in the last section, is one. The other is called **direct page indexed indirect addressing** or **preindexing** and uses the **X** register. It adds the index to the operand (a direct page base) to form a direct page offset at which the indirect address (the address of the data to be accessed) is located.

In effect, preindexing lets you index into a double-byte array of absolute memory addresses based in the direct page to choose the memory location to access; the array begins at the direct page offset specified by the operand.

Since the array base is a direct page location, adding the direct page register value yields the absolute location in bank zero. The processor then adds the value in the **X** register, which is the index into the array of memory locations. Now the processor finally has an address that holds the memory location you want to access; it now gets the location and accesses the data at that location. This is shown in Figure 11.2. Since indexing is done in order to find the indirect address, this addressing mode is also called **preindexing**.

You'll find preindexing useful for writing routines which need to access data in a number of different locations in exactly the same way. For example, a tic-tac-toe game drawn on the screen has nine boxes to which an 'O' or an 'X' might be written. The tic-tac-toe program might keep internal arrays of information about the content of each of the nine boxes, as well as arrays of data for working its win-seeking algorithms, using indexes from 0 to 8 to represent the locations.

When it comes time for the program to write an 'X' to a chosen square, you could, of course, write nine nearly identical routines which differ only in the address to which the 'X' will be written; you would also have to write a tenth routine to select which one of the routines needs to be called, based on the value of the box index (from zero to eight).

When it comes time for the program to write an 'X' to a chosen square, you could, of course, write nine nearly identical routines which differ only in the address to which the 'X' will be written; you would also have to write a tenth routine to select which one of the routines needs to be called, based on the value of the box index (from zero to eight).

A faster and less wasteful method of writing the 'X' would be to use pre-indexing. In the section of code which initially draws the tic-tac-toe grid, you would determine the nine addresses where characters are to be direct page offset \$50; this puts the 0 location at \$50 and \$51 (stored, in 65x fashion, low byte in \$50 and high byte in \$51), the 1 location at \$52 and 53, and so on. The nine addresses use 18 bytes of memory.

When an 'X' is to be stored to one of the nine screen locations, only one routine is necessary: you multiply the box number by two (using the **ASL** instruction). Remember that each indirect address takes up two bytes in the direct page array. Transfer it to the X register. Then load an 'X' character into the accumulator and write it to the box on the screen using preindexing as Fragment 11.10 shows.

0000	AD0080	WRITEX	LDA	BOXNUMBER	get which box to write an 'X' to
0003	0A		ASL	A	multiply by two to get index
0004	AA		TAX		and transfer index to X register
0005	A958		LDA	#'X'	write 'X' character
0007	8150		STA	(\$50,X)	to scrn location at (dp:\$50, index reg)

Fragment 11.10

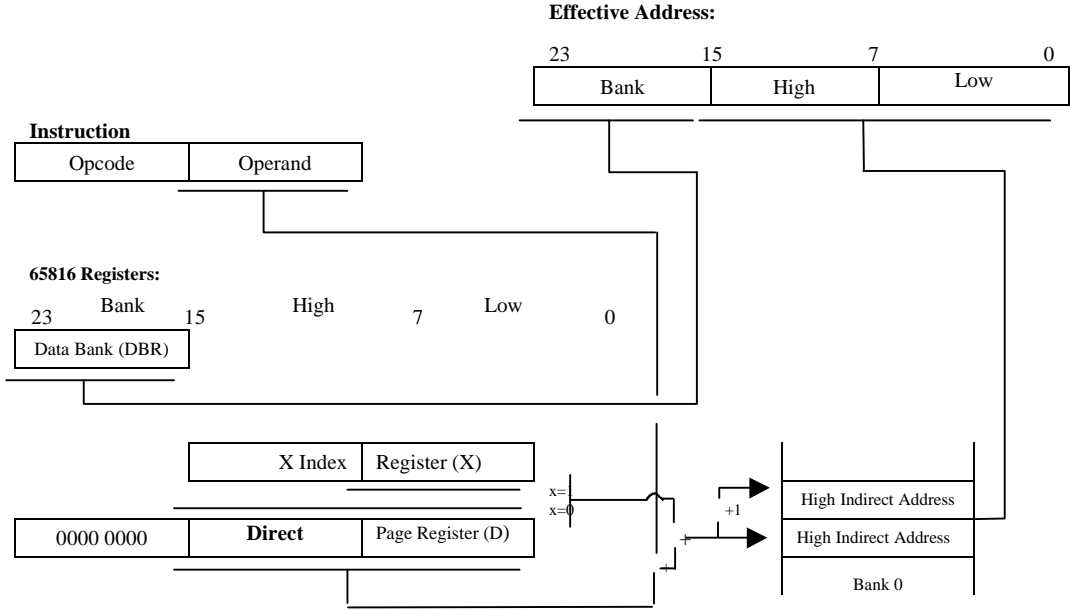

Figure 11-2 Preindexing

## The Western Design Center

Notice the differing syntax: postindexing looked like this:

```
9128          STA          (BASL),Y
```

In postindexed, the operand locates the direct address, so it's in parentheses to indicate indirection. The, "Y" is not in parentheses, since the index register is not part of finding the indirect address – it's added to the indirect address once it is found.

On the other hand, with preindexing:

```
8150          STA          ($50,X)
```

both the operand and the index register are involved in locating the indirect address, so both are in parentheses.

A very different application for preindexing enables the 65x to read from (or write to) several I/O peripherals "at once." Obviously, a microprocessor can only read from one device at a time, so it polls each device: provided each device uses the same I/O controller chip (so that a single routine can check the status of all devices and read a character from each of them identically), your program can poll the various status locations using pre-indexing. Begin by storing an array of all the status locations in the direct page. Specify the base of the array as the operand to preindexed instruction. Load the **X** index with 0 and increment it by two until you've checked the last device. Finally, restore it to zero and cycle through again and again.

If a status check reveals a character waiting to be read, your program can branch to code that actually reads the character from the device. This time, you'll use preindexing to access a second direct page array of the character-reading addresses for each device; the index in the **X** register from the status-checking routine provides the index into the character-reading routine.

On the 6502, the 65C02, and the 6502 emulation modes, the entire array set up for preindexing must be in the direct page. (On the 6502 and 65C02, this means the array must be entirely in the zero page which, unfortunately, severely limits the use of preindexing due to the competition for zero page locations.) If the specified direct page offset plus the index in the **X** exceeds \$FF, the array wraps around within the direct page rather than extending beyond it. That is,

```
A21A          LDX          #$1A
```

followed by

```
A1F0          LDA          ($F0,X)
```

would load the accumulator from the indirect address in location \$0A not \$10A.

On the 65802 and 65816 (in native mode), the array must still start in the direct page but wraps, not at the end of the direct page but at the end of bank zero, when the array base plus the **D** direct page setting plus the **X** index exceeds \$00:FFFF.

On the 65816, the data that is ultimately accessed (after the indirection) is always in the *data bank*.

## Absolute Indexed Indirect Addressing

The 65C02 introduced a new addressing mode, **absolute indexed indirect addressing**, which is quite similar to direct page indexed indirect. (It is also preindexed using the **X** index register, but indexes into absolute addressed memory rather than the direct page to find the indirect address.) This new addressing mode is used only by the jump instruction and, on the 65802 and 65816, the jump-to-subroutine instruction.

Absolute indexed indirect provides a method for your program, not to *access* data in scattered locations by putting the locations of the data into a table and indexing into it, but to *jump* to routines at various locations by putting those locations into a table, indexing into it, and jumping to the location stored in the stored in the table at the index. Figure 11.3 shows what happens.

## The Western Design Center

A menu-driven program, for example, could ask users to respond to a prompt by pressing a number key from '0' through '7'. Your program would convert the key's value to an index by subtracting the ASCII value of '0' and doubling the result (to reflect the fact that each table entry is an address and thus takes two bytes in the table) (Fragment 11.11). It would then jump indexed indirect to a routine appropriate to the menu choice.

0000		;		get menu choice into accumulator
0000	38		SEC	set carry before subtract
0001	E93000		SBC	#'0'
0004	0A		ASL	A
0005	AA		TAX	
0006	7C0900		JMP	(TABLE,X)
0009				
0009	0080	TABLE	DC	A'ROUTIN0'
000B	0080		DC	A'ROUTIN1'
000D	0080		DC	A'ROUTIN2'
000F	0080		DC	A'ROUTIN3'
0011	0080		DC	A'ROUTIN4'
0013	0080		DC	A'ROUTIN5'
0015	0080		DC	A'ROUTIN6'
0017	0080		DC	A'ROUTIN7'

**Fragment 11.11**

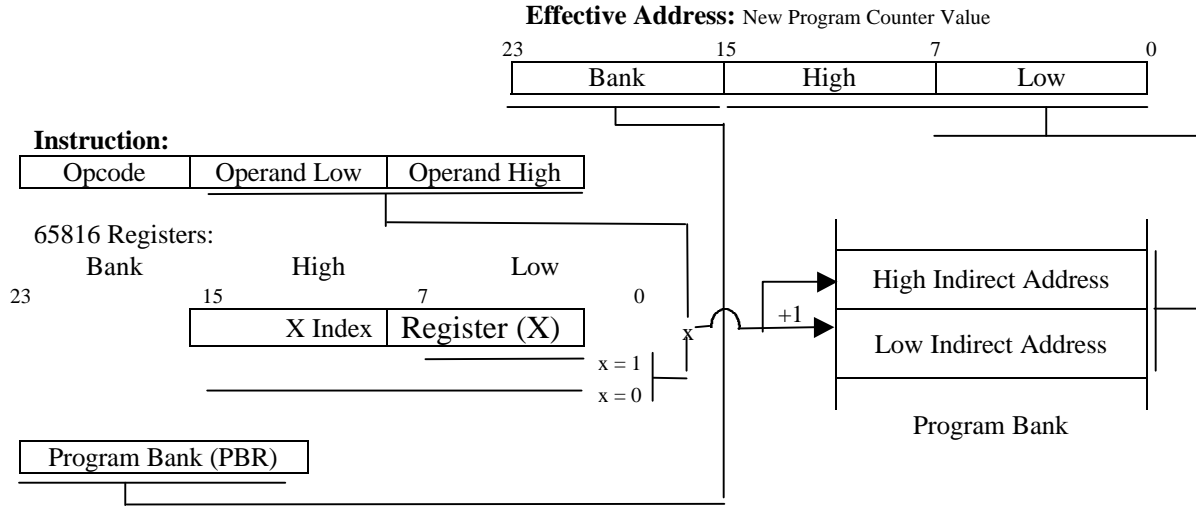

**Figure 11-3 Absolute Indexed Indirect**

Because both the operand (the absolute address of the base of the table) and the index register are involved in determining the indirect address, both are within the parentheses.

On the 65816, a jump-indirect operand is in bank zero, but a jump-indexed-indirect operand is in the *program* bank. There is a different assumption for each mode. Jump indirect assumes that the indirect address to be jumped to was stored by the program in a variable memory cell; such variables are generally in bank zero. Jump indexed indirect, on the other hand, assumes that a table of locations of routines would be part of the program itself and would be loaded, right along with the routines, into the bank holding the program. So,

```
6C3412    JMP    ($1234)    jump to address stored at $00:1234.1235
```

assumes \$1234 is in a double-byte cell in bank zero. But

```
7C3412    JMP    (1234,X)    jump to address stored at pb:$1234,X
```

assumes \$1234 is in the program bank, the bank in which the code currently being executed resides.

The indirect addresses stored in the table are absolute addresses also assumed to be in the current program bank.

### Direct Page Indirect Long Indexed with Y Addressing

The 65816 can access sixteen megabytes of memory, yet lets you access most data (data located in the current data bank) with just two bytes. Nevertheless, there are times when data must be accessed in a bank other than the current data bank when it would be inconvenient to change the data bank, then change it back. As Chapter 7 pointed out, this problem is solved by the “long” addressing modes, which allow three bytes (the bank in addition to the address within the bank) to specify a full 24-bit address. This solution lets you access the 65816’s full sixteen-megabyte address space. Probably the most useful way to reference data outside of the current data bank is via the **direct page indirect long indexed with Y**, or **postindexed long**, addressing mode. This is the long version of direct page indirect indexed addressing, discussed earlier in this chapter.

Instructions are two bytes in length, as shown in Fragment 11.4: The opcode is followed by a single byte, which is a direct page offset in bank zero. The indirect address stored in the direct page (to which the operand points) is, in the long version, three bytes (a full 24-bit address); the byte at the direct page offset is the low byte of the 24-bit address, the byte in the next direct page location the middle byte of the 24-bit address,

## The Western Design Center

and the byte in the third location the bank byte of the 24-bit address. The contents of the **Y** index register are added to this 24-bit address to form the 24-bit effective address at which data will be accessed.

The syntax for postindexed long is:

```
B715          LDA          [$15],Y
```

The square brackets are used to indicate the indirect address is long.

So, like its sixteen-bit counterpart, indirect long indexed addressing allows you to index into an array of which neither the base nor the index need be determined until the program is executing. Unlike its sixteen-bit counterpart, it allows you to access an array in *any* bank, not just the current data bank.

## Stack Relative Addressing

Possibly the most exciting new addressing method introduced by the 65802 and 65816 is stack relative. This is the first 65x method for directly accessing a stack byte other than the last data item pushed.

Stack relative addressing lets you easily access any byte or address in the last \$FF bytes stacked. Instructions using stack relative addressing are two bytes long, the operand a single byte that is an index into the stack. As Figure 11.5 shows, the stack is treated as an array with its base the address in the stack pointer. The operand is added to the stack pointer value to form the bank zero effective address which will be accessed.

This can be especially useful when one part of a program needs to send data to another part of the program, such as a multiply routine. The two sixteen-bit values to be multiplied are pushed onto the stack in one part of the program. Later, the multiply routine loads one of the operands using stack relative addressing, leaving both the other operand and the stack pointer undisturbed:

```
A303          LDA          3,S          load first operand
```

or

```
A301          LDA          3,S          load second operand
```

Notice that accessing the last data put on the stack requires an index of 1, not of 0. This is because the stack pointer always points to the *next available* location, which is one byte below the last byte pushed onto the stack. An index of zero would generally be meaningless, except perhaps to re-read the last byte *pulled off* the stack! (The latter would also be extremely dangerous since, should an interrupt occur, the left-behind byte would be overwritten by interrupt-stacked bytes.)

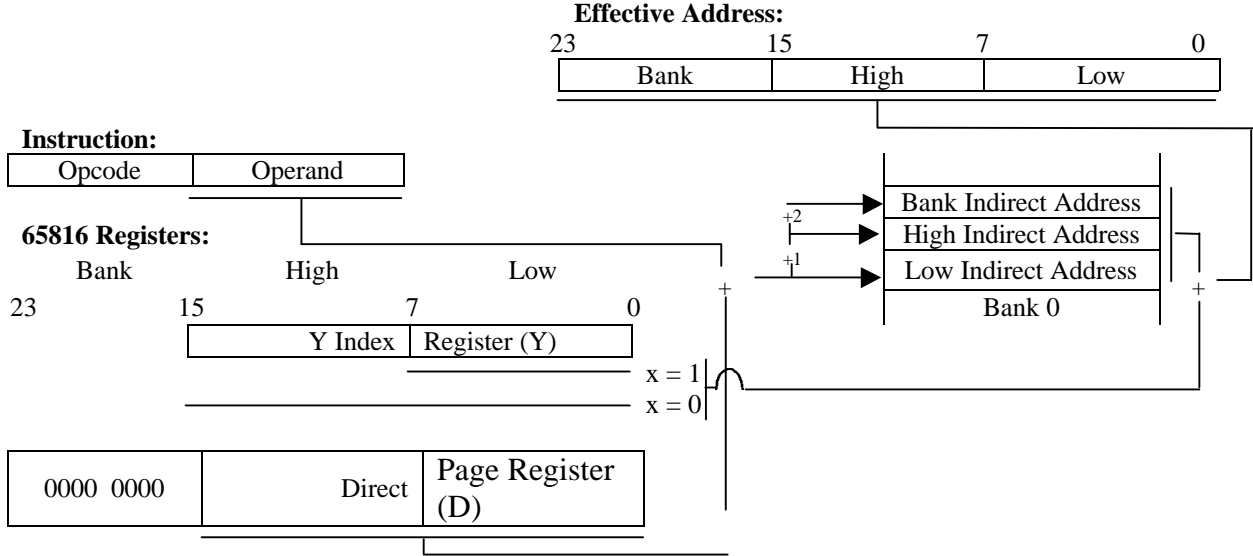

Figure 11-4 Postindexed Long

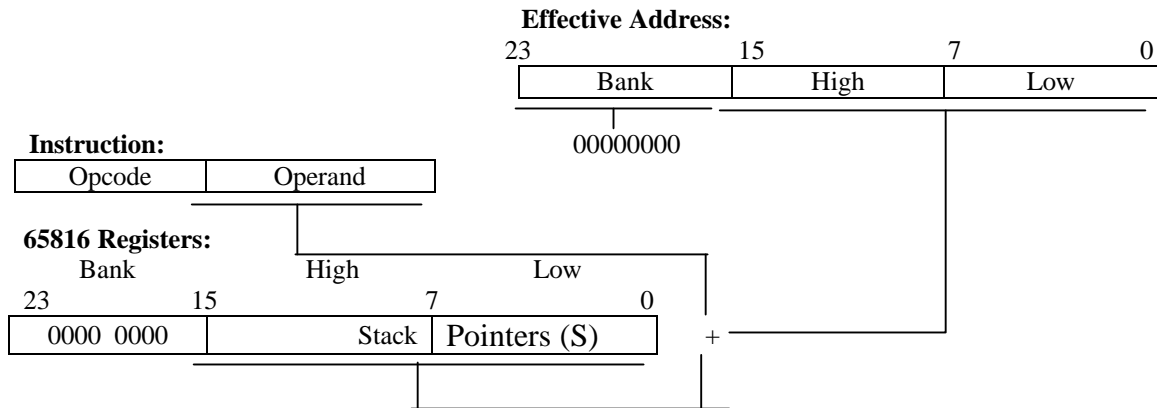

Figure 11-5 Stack Relative

### Stack Relative Indirect Indexed Addressing

While the stack relative addressing mode serves to access data on the stack, the stack relative indirect indexed addressing mode lets you access data indirectly through *addresses* that have been pushed onto the stack.

Change the previous example: Instead of stacking the two sixteen-bit values to be multiplied, the values are found in memory cells in the data bank, one after the other (occupying four consecutive bytes), and it's the address of the first that is pushed onto the stack. Now, Fragment 11.12 shows, either value can be loaded using the stack indirect address:

0000	A00000	LDY	#0	
0003	B301	LDA	(1,S),Y	load first 16-bit multiply operand
0005	AA	TAX		save first value
0006	A00200	LDY	#2	
0009	B301	LDA	(1,S),Y	load second 16-bit multiply operand

Fragment 11.12

The 1,S is the stack location where the indirect address was pushed. (Actually, 1,S points to the stack location of the low byte of the indirect address; the high byte is in 2,S, the next higher stack location.) To this indirect address, the value in the **Y** is added: the indirect address plus 0 locates the first value to be multiplied; the indirect address plus 2 locates the second. Finally the accumulator is loaded from this indirect indexed address. Figure 11.6 illustrates the sequence.

This mode, very similar to direct page indirect indexing (also called postindexing), might be called "stack postindexing." The operand which indexes into the stack is very similar to a direct page address; both are limited to eight bits and both are added to a sixteen-bit base register (**D** or **S**). In both cases, the indirect address points to a cell or an array in the data bank. In both cases, **Y** must be the index register. And in both cases in the 65816, the postindexed indirect address about to be accessed may extend out of the data bank and into the next bank if index plus address exceeds \$FFFF; that is, if the indirect address is the base of an array, the array can extend into the next bank.



Push Effective Instructions

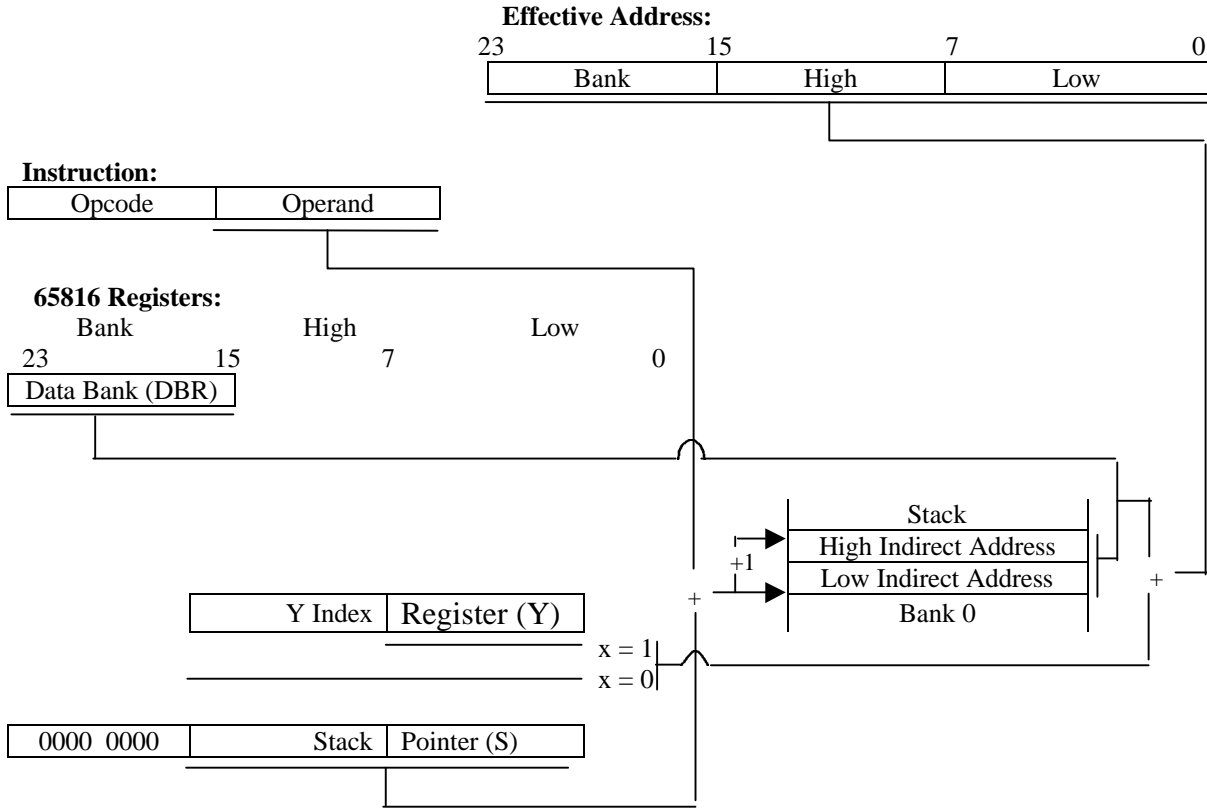

Figure 11-6 Stack Relative Indirect Indexed

As Figure 11.7 shows, the **PEA**(push effective absolute address) instruction pushes the operand, a The 65802 and the 65816 provide three instructions which push, not registers, but absolute, indirect, and relative addresses straight onto the stack. These three instructions are **PEA**, **PEI**, and **PER**, the **push effective address** instructions. Addresses so pushed might be accessed, for example, using the stack relative indirect indexed addressing mode just discussed. Chapter 6, which introduced the push instructions in the context of data movement, deferred discussion of these three instructions to this chapter. Except for the block move instructions, these are the only instructions that move data directly from one memory location to another.

16-bit absolute address or immediate data word, onto the stack. For example,

```
F43421      PEA      $2134      push $2134 onto the stack
```

pushes what may be either sixteen-bit immediate data or a sixteen-bit address onto the stack. The operand pushed by the **PEA** instruction is always 16 bits regardless of the settings of the **m** memory/accumulator and **x** index mode select flags.

The **PEI** (push effective indirect address) instruction has, as an operand, a direct page location: it's the sixteen-bit value stored at the location that is pushed onto the stack. Figure 11.8 shows that this has the effect of pushing either an indirect address or sixteen bits of direct page data onto the stack. For example, if you had stored the value or indirect address \$5678 at direct page location \$21, then

```
D421      PEI      ($21)      push two bytes at dp:$21 and dp:$22
```

## The Western Design Center

would get the \$5678 from direct page location and push it onto the stack. Like the **PEA** instruction, the **PEI** instruction always pushes sixteen bits regardless of the settings of the **m** memory/accumulator and **x** index node select flags.

The **PER** (push effective relative) instruction pushes an effective program counter relative address onto the stack, a capability helpful in writing relocatable code. The operand you specify to the assembler is a location in the program, for example, of a data area; the operand the assembler generates is a sixteen-bit relative displacement, the difference between the next instruction's *run-time* address and the operand address. Figure 11.9 shows that when the instruction is executed, the displacement is added to the next instruction's *run-time* address to form the address at which the data is now located it is this address which is pushed onto the stack. If the data location precedes the **PER** instruction, the assembler generates a very large sixteen-bit displacement which, when added to the program counter value, will wrap around within the program bank to reach the data.

The operation of the **PER** instruction is similar to the operation of the **BRL** (branch long) instruction: the branch long operand you specify to the assembler is also a

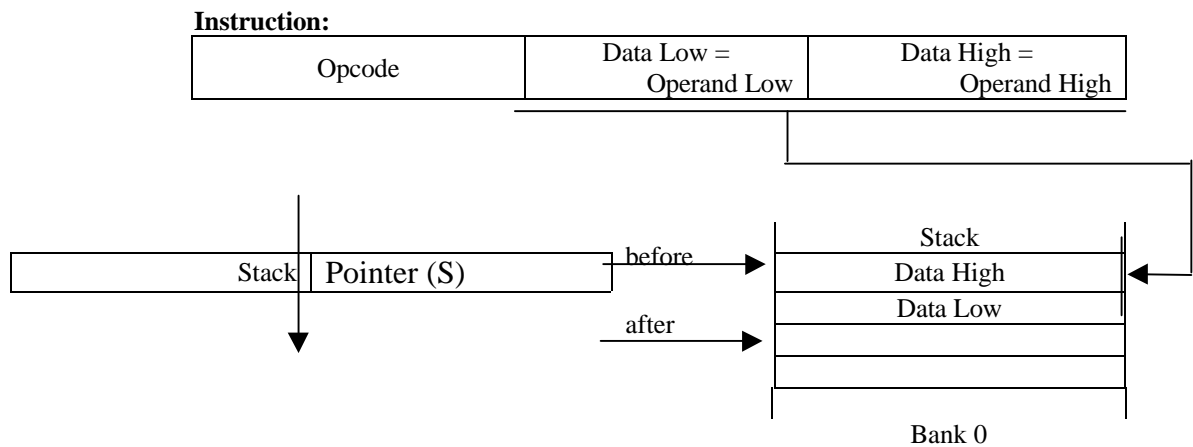

Figure 11-7 PEA Addressing

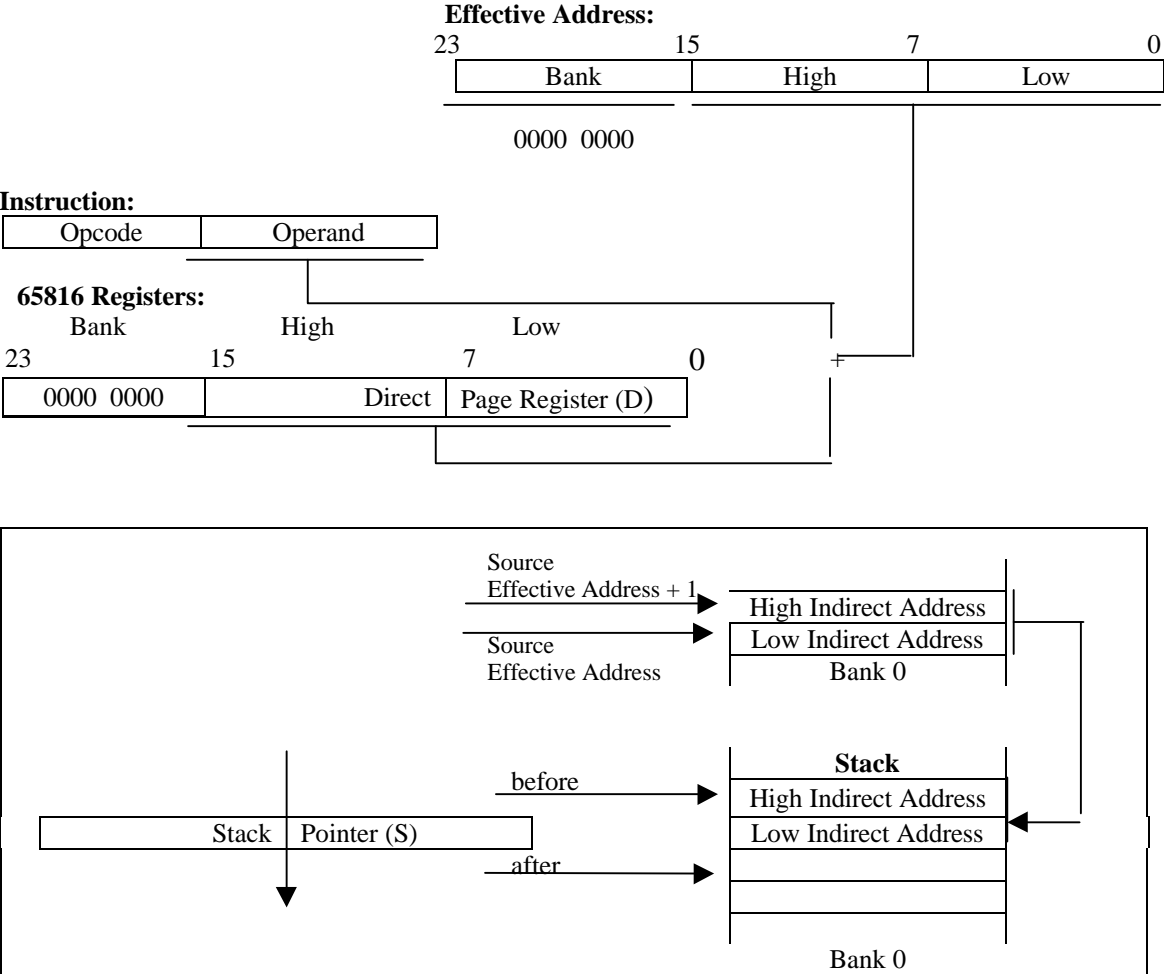

Figure 11-8 PEI Addressing

The Western Design Center

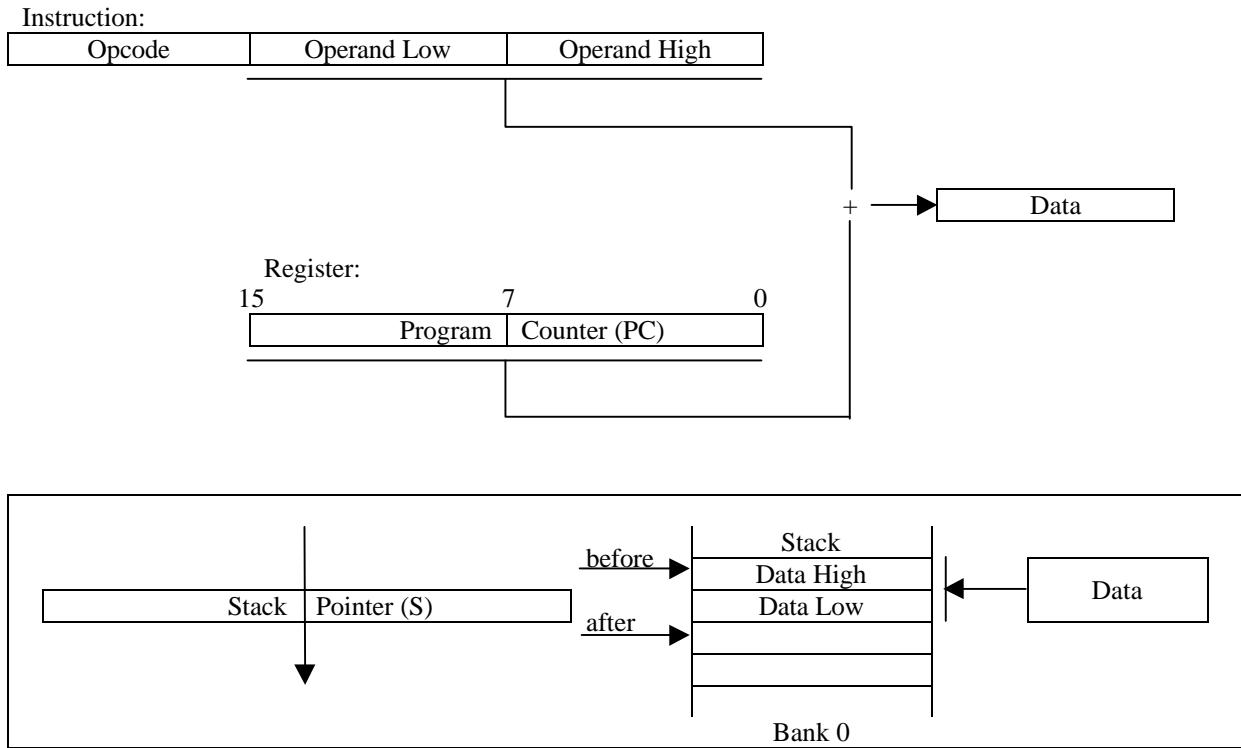

Figure 11-9. PER Addressing

location in the program; the operand the assembler generates is also a sixteen-bit displacement; and when the instruction is executed, the displacement is added to the next instruction's run-time address to form the address to which the program will branch.

To understand the use of the **PER** instruction, together with the relative branches, in writing a program that will run at *any* address, suppose that your relocatable program is assembled starting at location \$2000. There's a data area starting at location \$2500 called **DATA0**. A section of program code at \$2200 needs to access a byte three bytes past, called **DATA1**. A simple **LDA \$2503** would work, but only if the program were intended to always begin at location \$2000. If it's meant to be relocatable, you might load the program at \$3000, in which case the data is at \$3503 and a **LDA \$2503** loads the accumulator with random information from what is now a non-program address. Using the instruction

```
62E17F          PER      DATA3      push address of DATA3 relative to PC
```

in your source program causes the assembler to calculate the offset from \$2203 (from the instruction following the **PER** instruction at \$2200) to **DATA1** at \$2503, an offset of \$300. So the assembler generates object code of a **PER** opcode followed by \$300. Now if the code is loaded at \$3000, execution of the **PER** instruction causes the processor to calculate and stack the current absolute address of **DATA1** by adding the operand, \$300, to the current program counter location; the result is \$3503, so it's \$3503 that's stacked. Once on the stack, provided the program and data banks are the same, the data can be accessed using stack relative indirect indexed addressing. Fragment 11.13 contains the example code.

Once the address of **DATA1** is on the stack, the values at **DATA2** and **DATA3** can be accessed as well simply by using values of one and two, respectively, in the **Y** index register.

## The Western Design Center

0000			ORG	\$2200	
0000		ACCESS	START		
0000					
0000	62FD7F		PER	DATA1	push run-time address of DATA1 onto stack
0003	E220		SEP	#\$20	set accum to 8-bit mode
0005	A00000		LDY	#0	zero index: DATA1 is cell, not array
0008	B301		LDA	(1,S),Y	load accum from DATA1 in data ban
000A		;			(address of DATA1 @ 1,S & 2,S)
000A			.		
000A			.		
000A			.		
000A					
000A			END		
0000					
0000			ORG	\$2500	
0000		DATA0	START		
0000	2A2A2A		DC	C'***'	
0003	FF	DATA1	DC	H'FF'	
0004	F7	DATA2	DC	H'F7'	
0005	E3	DATA3	DC	H'E3'	
0006					
0006			END		

Fragment 11.13

# 12) Chapter Twelve

## The Basic Building Block:

### The Subroutine

The feature essential to any processor to support efficient, compact code, as well as modular or top-down programming methods, is a means of defining a **subroutine**. A subroutine is a block of code that can be entered (called) repeatedly from various parts of a main program, and that can automatically return control to the instruction following the calling instruction, wherever it may be. The 65x jump-to-subroutine instruction provides just such a capability.

When a jump-to-subroutine, or **JSR**, instruction is encountered, the processor first pushes its current location onto the stack for purposes of returning, then jumps to the beginning of the subroutine code. At the end of the subroutine code, a return-from-subroutine (**RTS**) instruction tells the processor to return from the subroutine to the instruction after the subroutine call, which it locates by pulling the previously saved return location from the stack.

Because subroutines let you write a recurring section of program code just once and call it from each place that it's needed, they are the basis of top-down, structured programming. Common subroutines are often collected together by programmers to form a **library**, from which they can be selected and reused as needed.

Chapter 8, Flow of Control, introduced the 65x jump instructions – those flow-of-control instructions which do *not* use the stack for return purposes. But discussion of the jump-to-subroutine instructions was put off to this chapter.

Table 12.1 lists the instructions to be explained in this chapter. In addition, this chapter will use the simple example of a negation routine to illustrate how library routines (and routines in general) are written and documented, and it examines the question of when to code a subroutine and when to use in-line code. Finally, methods of passing information (or **parameters**) to and from subroutines are compared and illustrated.

Mnemonic	Available on:			Description
	6502	65C02	65802/816	
<i>65x Subroutine Instructions:</i>				
JSR	x	x	x	jump to subroutine
RTS	x	x	x	return from subroutine
JSL			x	long jump to subroutine
RTL			x	long return from subroutine

**Table 12-1 Subroutine Instructions**

## The Western Design Center

### The Jump-To-Subroutine Instruction

There is just one addressing mode available to the **JSR** instruction on the 6502 and 65C02 – absolute addressing. This mode lets you code a subroutine call to a known location. When used on the 65816, that location must be within the current *program* bank. It uses the absolute addressing syntax introduced earlier:

```
200020      JSR          $2000          jump to subroutine located at pb:$2000
```

or

```
200080      JSR          SUBR1         jump to subroutine SUBR1 in program bank
```

In the second case, the assembler determines the address of subroutine **SUBR1**.

The processor, upon encountering a jump-to-subroutine instruction, first saves a return address. The address saved is the address of the *last byte* of the **JSR** instruction (the address of the last byte of the operand), not the address of the next instruction as is the case with some other processors. The address is pushed onto the stack in standard 65x order – the low byte in the lower address, the high byte in the higher address – and done in standard 65x fashion – the first byte is stored at the location pointed to by the stack pointer, the stack pointer is decremented, the second byte is stored, and the stack pointer is decremented again. Once the return address has been saved onto the stack, the processor loads the program counter with the operand value, thus jumping to the operand location, as shown in Figure 12.1. Jumping to a subroutine has no effect on the status register flags.

### The Return-from-Subroutine Instruction

At the end of each subroutine you write, the one-byte **RTS**, or **return-from-subroutine**, instruction must be coded. When the return-from-subroutine instruction is executed, the processor pulls the stored address from the stack, incrementing the stack

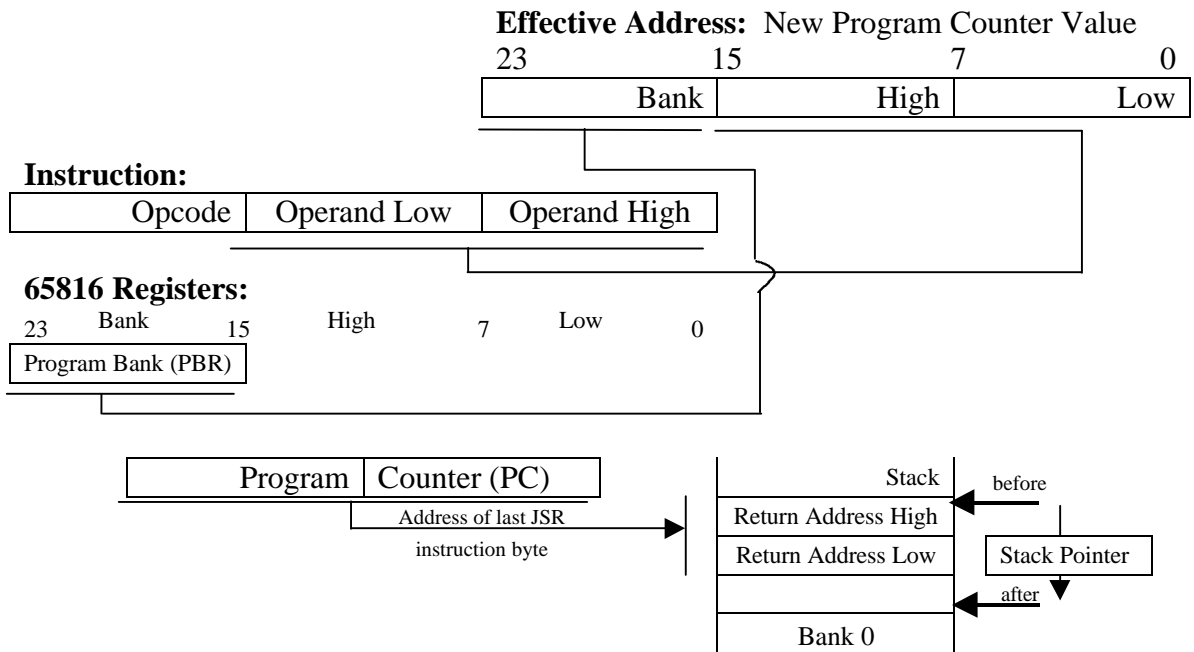

Figure 12-1 JSR

pointer by one before retrieving each of the two bytes to which it points. But the return address that was stored on the stack was the address of the *third byte of the JSR instruction*. When the processor pulls the return address off the stack, it automatically increments the address by one so that it points to the instruction following the **JSR** instruction which should be executed when the subroutine is done. The processor loads this incremented return address into the program counter and continues execution from the instruction following the original **JSR** instruction, as Figure 12.2 shows.

The processor *assumes* that the two bytes at the top of the stack are a return address stored by a **JSR** instruction and that these bytes got there as the result of a previous **LSR**. But as a result, if the subroutine used the stack and left it pointing to data other than the return address, the **RTS** instruction will pull two irrelevant data bytes as the address to return to. Cleaning up the stack after using it within a subroutine is therefore imperative.

The useful side of the processor's inability to discern whether the address at the top of the stack was pushed there by a **JSR** instruction is that you can write a reentrant indirect jump using the **RTS** instruction. First formulate the address to be jumped to, then decrement it by one (or better, start with an already-decremented address), push it onto the stack (pushing first high byte, then low byte, so that it is in correct 65x order on the stack) and, finally, code an **RTS** instruction. The return-from-subroutine pulls the address back off the stack, increments it, and loads the result into the program counter to cause a jump to the location, as Fragment 12.1 illustrates.

0000		;	16-bit accumulator holds address of code to jump to
0000	3A	DEC	A DEST - 1: address of byte before target
0001	48	PHA	push it; now address is stacked as tho JSR
0002	60	RTS	pull address; increment it; transfer control

Fragment 12.1

**Reentrancy** is the ability of a section of code to be interrupted, then executed by the interrupting routine, and still execute properly both for the interrupting routine and for the original routine when control is returned to it. The interruption may be a result of a hardware interrupt (as described in the next chapter), or the



## The Western Design Center

result of the routine calling itself, in which case the routine is said to be recursive. The keys to reentrancy are, first, to be sure you save all important registers before reentering and, second to use no fixed memory locations in the reentrant code. (There will be more on interrupts and reentrancy in the next chapters.)

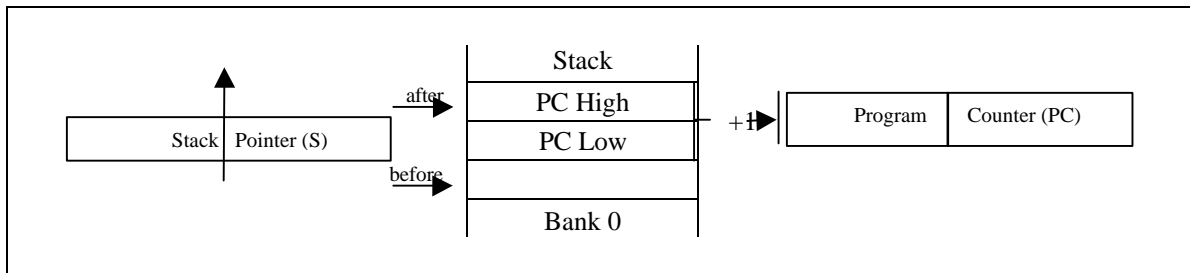

Figure 12-2 RTS

The indirect jump using **RTS** qualifies for reentrancy: While normally you would code an indirect jump by forming the address to jump to and storing it to an absolute address, then jumping indirect through the address, this jump by use of **RTS** uses only registers and stack.

A subroutine can have more than one **RTS** instruction. It's common for subroutine from internal loops upon certain error conditions, in addition to returning normally from one or more locations. Some structured programming purists would object to this practice, but the efficiency of having multiple exit points is unquestionable.

Returning from a subroutine does not affect the status flags.

## JRS Using Absolute Indexed Indirect Addressing

The 65802/65816 gives **JSR** another addressing mode – absolute indexed indirect (covered in the last chapter) which lets your program select, on the basis of the index in the register, a subroutine location from a table of such locations and call it:

FC0080      JSR      (TABLE,X)      JSR to indirect address in (TABLE at X)

The array **Table** must be located in the program bank. The addressing mode assumes that a table of locations of routines would be part of the program itself and would be loaded, right along with the routines, into the bank holding the program. The indirect address (the address with which the program counter will be loaded), a sixteen-bit value, is concatenated with the program bank register, resulting in a transfer within the current program bank. If the addition of X causes a result greater than \$FFFF, the effective address will wrap, remaining in the current program bank, unlike the indexing across banks that occurs for data accesses.

This addressing mode also lets you do an indirect jump-to-subroutine through a single double-byte cell by first loading the X register with zero. You must remember in coding this use for the 65816, however, that the cell holding the indirect address is in the program bank, *not* bank zero as with absolute indirect jumps.

The indexed indirect jump-to-subroutine is executed in virtually the same manner as the absolute jump-to-subroutine: the processor pushes the address of the final byte of the instruction onto the stack as a return address; then the address in the double-byte cell pointed to by the sum of the operand and the X index register is loaded into the program counter.

There is no difference between returning from a subroutine called by this instruction and returning from a subroutine called by an absolute **JSR**. You code an **RTS** instruction which, when executed, causes the address on the top of the stack to be pulled and incremented to point to the instruction following the **JSR**, then to be loaded into the program counter to give control to that instruction.

## The Long Jump to Subroutine

A third jump-to-subroutine addressing mode is provided for programming in the 16-megabyte address space of the 65816 – absolute long addressing. Jump-to-subroutine absolute long is a four-byte instruction, the operand a 24-bit address in standard 65x order (the low byte of the 24-bit address is in the lowest memory location immediately following the opcode and the high byte is next, followed by the bank byte):

```
22563412    JSR        $123456        jump to subroutine at $3456 in bank $12
```

This time a three-byte (long) return address is pushed onto the stack. Again it is not the address of the next instruction but rather the address of the last byte of the **JSR** instruction which pushed onto the stack (the address of the fourth byte the **JSR** instruction in this case). As Figure 12.3 shows, the address is pushed onto the stack in standard 65x order: low byte in the lower address, high byte in the higher address, bank byte in the highest address (which also means the bank byte is the first of the three pushed, the low byte last).

Jumping long to a bank zero subroutine requires the greater-than (>) sign, as explained in the last chapter:

```
22563400    JSR        >$3456        long jump to subroutine at $3456 in bank 0
```

The greater-than sign forces long addressing to bank zero, voiding the assembler’s normal assumption to use absolute addressing to jump to a subroutine at \$3456 in the current program bank.

To avoid this confusion altogether, there is an equivalent standard mnemonic for jump-to-subroutine long – **JSL**:

```
22563400    JSL        $3456        long jump to subroutine at $3456 in bank 0
```

or

```
22563402    JSL        $023456        long jump to subroutine at $3456 in bank 2
```

Using an alternate mnemonic is particularly appropriate for jump-to-subroutine long, since this instruction *requires* you to use an entirely different return-from-subroutine instruction – **RTL**, or **return-from-subroutine long**.

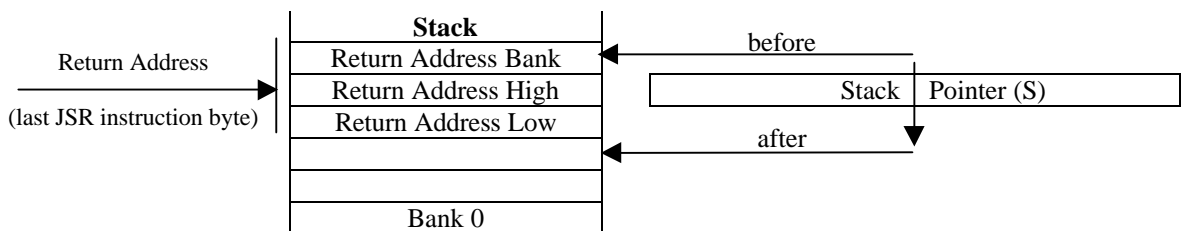

Figure 12-3 JSL

## Return from Subroutine Long

The return from subroutine instruction pops two bytes off the stack as an absolute address, increments it, and jumps there. But the jump to subroutine long instruction pushes a *three-byte* address onto the stack – a *long* return address that points to the original code, and is typically in a bank different from the subroutine bank.

So the 65816 provides a return from subroutine long instruction, **RTL**. This return instruction first pulls, increments, and loads the program counter, just as **RTS** does; then it pulls and loads a third byte, the program bank register, to jump long to the return address. This is illustrated in Figure 12.4.

### Branch to Subroutine

One of the glaring deficiencies of the 6502 was its lack of support for writing relocatable code; the 65802 and 65816 address this deficiency, but still lack the branch-to-subroutine instruction some other processors provide. There is no instruction that lets you call a subroutine with an operand that is program counter relative, not an absolute address. Yet, to write relocatable code easily, a **BSR** instruction is required: suppose a relocatable program assembled at \$0 has an often-called multiply subroutine at \$07FE; if the program is later loaded at \$7000, that subroutine is at \$77FE; obviously, a **JSR** to \$07FE will fail.

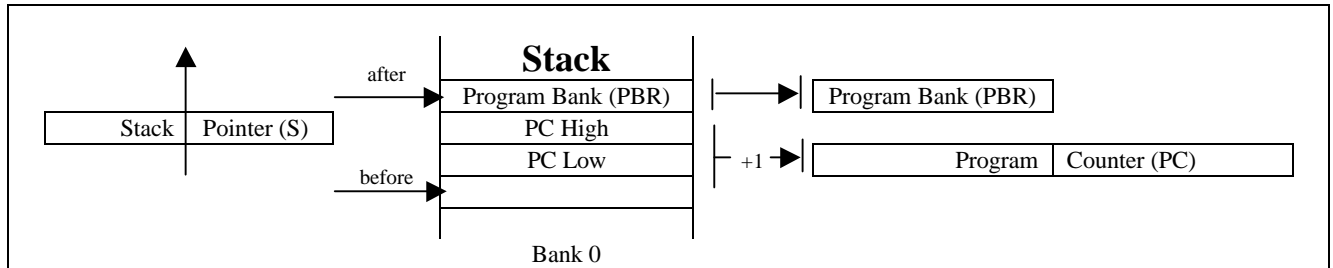

Figure 12-4 RTL

The 65802 and 65816 can synthesize the **BSR** function using their **PER** instruction. You use **PER** to compute and push the current run-time return address; since its operand is the return address' relative offset (from the current address of the **PER** instruction), **PER** provides relocatability. As Fragment 12.2 shows, once the correct return address is on the stack, a **BRA** or **BRL** completes the synthesized **BSR** operation.

0000		.		
0000		.		
0000		.		
0000	62FC7F	PER	RETURN-1	push run-time return address
0003	82FA7F	BRL	SUBR1	intra-bank relative branch is BSR
0006		RETURN	.	continue processing here
0006		.		
0006		.		
0006		.		
0006		SUBR1	.	
0006		.		execute subroutine function
0006		.		
0006		.		
0006	60	RTS		return from subroutine

Fragment 12.2

In this case, you specify as the assembler operand the symbolic location of the routine you want to return to *minus one*. Remember that the return address on the stack is pulled, *then incremented*, before control is passed to it. The assembler transforms the source code operand, **RETURN - 1**, into the instruction's object code operand, a relative displacement from the next instruction to **RETURN - 1**. In this case, the displacement is \$0002, the difference between the first byte of the **BRL** instruction and its last byte. (Remember, **PER** works the same as the **BRL** instruction; in both cases, the assembler turns the location you specify into a relative displacement from the program counter.) When the instruction is executed, the processor adds the displacement (\$0002, in this case) to the current program counter address (the address of the **BRL** instruction); the resulting sum is the current absolute address of **RETURN - 1**, which is what is pushed onto the stack.

## The Western Design Center

If at run-time the **PER** instruction is at \$1000, then the **BRL** instruction will be at \$1003, and **RETURN** at \$1006. Execution of **PER** pushes \$1005 onto the stack, and the program branches to **SUBR1**. The **RTS** at the end of the subroutine causes the \$1005 to be pulled from the stack, incremented to \$1006 (the address of **RETURN**), and loaded into the program counter.

If, on the other hand, the instructions are at \$2000, \$2003, and \$2006, then \$2005 is pushed onto the stack by execution of **PER**, then pulled off again when **RTS** is encountered, incremented to \$2006 (the current run-time address of **RETURN**), and loaded into the program counter.

If a macro assembler is available, synthetic instructions such as this are best dealt with by burying this code in a single macro call.

## Coding a Subroutine: How and When

The uses of subroutines are many. At the simplest level, they let you compact in a single location instructions that would otherwise be repeated if coded in-line. Programmers often build up libraries of general subroutines from which they can pluck the routine they want for use in a particular program; even if the routine is only called once, this allows quick coding of commonly used functions.

The next few pages will look at a simple logic function for the 65x processors – forming the negation (two's complement) of eight- and sixteen-bit numbers – and how such a routine is written. Also covered is how subroutines in general (and library routines in particular) should be documented.

The 65x processors have no negate instruction, so the two's complement is formed by complementing the number (one's complement) and adding one.

### 6502 Eight-Bit Negation – A Library Example

If the value to be negated is an eight-bit value, the routine in Listing 12.1 will yield the desired result.

0001	0000		KEEP	KL.12.1	
0002	0000				
0003	0000		; NEGACC - -		
0004	0000		;		
0005	0000		; Negate the 8-bit value in the accumulator		
0006	0000		; On entry: Value to be negated is in accumulator		
0007	0000		; On exit: Value now negated is in accumulator		
0008	0000				
0009	0000	NEGACC	START		
0010	0000	46FF	EOR	#\$11111111	form one's complement
0011	0002	18	CLC		prepare to add one
0012	0003	6901	ADC	#1	add one
0013	0005	60	RTS		return
0014	0006		END		

Listing 12.1

It is extremely important to clearly document library routines. Perhaps the best approach is to begin with a block comment at the head of the routine, describing its name, what the routine does, what it expects as input, what direct page locations it uses during execution, if the contents of any registers or any memory special locations are modified during execution, and how and where results are returned.

By documenting the entry and exit conditions as part of the header, as in the example, when the routine is used from a library you won't have to read the code to get this information. Although this example is quite simple, when applied to larger, more complex subroutines, the principle is the same: document the entry and exit conditions, the function performed, and any side effects.

As a subroutine, this code to negate the accumulator takes six bytes. Each **JSR** instruction takes three. So calling it twice from a single program requires 12 bytes of code; if called three times, 15 bytes; if four, 18 bytes.

## The Western Design Center

On the other hand, if this code were in-line once, it would take only five bytes, but each additional time it is needed would require another five bytes, so using it twice takes 10 bytes, three times takes 15, and four times takes 20. You can see that only if you need to negate the accumulator four or more times does calling as a subroutine make sense in view of object byte economy.

### *65C02, 65802, and 65816 Eight-Bit Negation*

The addition of the accumulator addressing mode for the **INC** increment instruction on the 65C02, 65802, and 65816 means no subroutine is required for negating an eight-bit value in the accumulator on these processors: the in-line code in Fragment 12.3 takes only three bytes.

0000	49FF	EOR	##11111111	form one's complement of accum
0002	1A	INC	A	increment the accum by one

**Fragment 12.3.**

Since the in-line code takes the same number of bytes as the **JSR** instruction, you would lose four bytes (the number in the subroutine itself) by calling it as a subroutine.

### *6502 Sixteen-Bit Negation*

Negating sixteen-bit values makes even more sense as a subroutine on the 6502. One method, given the previously-coded routine **NEGACC**, is shown in Listing 12.2.

0001	0000		KEEP	KL.12.2	
0002	0000				
0003	0000				
0004	0000				; Negate the 16-bit value in registers X – A (hi-lo)
0005	0000				; On entry: Value to be negated is in X – A (hi-lo)
0006	0000				; On exit: Value now negated is in A – Y (hi-lo)
0007	0000				; X is unchanged
0008	0000				; must be linked with NEGACC
0009	0000				
0010	0000		NEGXA	START	
0011	0000				; first call the 8-bit negation routine defined a few pages back
0012	0000	200080	JSR	NEGACC	negate the low 8 bits in the accum
0013	0003				; then get and negate the high 8 bits
0014	0003	A8	TAY		
0015	0004	8A	TXA		get high 8 bits into accum
0016	0005	49FF	EOR	##11111111	form one's complement
0017	0007	6900	ADC		add carry from adding 1 to low byte
0018	0009	60	RTS		return
0019	000A		END		

**Listing 12.2**

Here, one subroutine (**NEGXA**) calls another (the subroutine described previously that negates eight bits).

### *65802 and 65816 Sixteen-Bit Negation*

Fragment 12.4 shows that on the 65802 and 65816, the sixteen-bit accumulator can be negated in-line in only four bytes. As a result, a subroutine to negate the sixteen-bit accumulator would be inefficient, requiring five calls to catch up with the on-byte difference; in addition, you should note that there is a speed penalty associated with calling a subroutine – the time required to executed the **JSR** and **RTS** instructions.

## The Western Design Center

0000	49FFFF	EOR	#\$FFFF	form one's complement of accum
0003	1A	INC	A	increment the accum by one

### Fragment 12.4

## Parameter Passing

When dealing with subroutines, which by definition are generalized pieces of code used over and over again, the question of how to give the subroutine the information needed to perform its function must be considered. Values passed to or from subroutines are referred to as the parameters of the subroutine. Parameters can include values to be acted upon, such as two numbers to be multiplied, or may be information that defines the context or range of activity of the subroutine. For example, a subroutine parameter could be the address of a region of memory to work on or in, rather than the actual data itself.

The preceding examples demonstrated one of the simplest methods of parameter-passing, by using the registers. Since many of the operations that are coded are subroutines in assembly language are primitives that operate on a single element, like “print a character on the output device” or “convert this character from binary to hexadecimal,” passing parameters in registers is probably the approach most commonly found.

A natural extension of this approach, which is particularly appropriate for the 65802 and 65816, but also possible on the 6502 and 65C02, is to pass the address of a parameter list in a register (or, on the 6502 and 65C02, in *two* registers). Listing 12.3 gives example.

## The Western Design Center

0001	0000			KEEP	KL.12.3	
0002	0000			65816	ON	
0003	0000					
0004	0000		L123	START		
0005	0000	18		CLC		
0006	0001	FB		XCE		
0007	0002					
0008	0002	E220		SEP	#\$20	8-bit accumulator
0009	0004			LONGA	OFF	
0010	0004					
0011	0004	C210		REP	#\$10	16-bit index register
0012	0006			LONGI	ON	
0013	0006					
0014	0006	A21500		LDX	#STRING1	pass the address of STRING1 to PRSTRNG
0015	0009	2000080		JSR	PRSTRNG	print STRING1
0016	000C					
0017	000C	A22800		LDX	#STRING2	pass the address of STRING2 to PRSTRNG
0018	000F	200080		JSR	PRSTRNG	print STRING2
0019	0012					
0020	0012	38		SEC		
0021	0013	FB		XCE		
0022	0014	60		RTS		
0023	0015					
0024	0015	54686973	STRING1	DC	C 'This is string one', H '00'	
0025	0028	54686973	STRING2	DC	C 'This is string two', H '00'	
0026	003B					
0027	003B			END		
0028	0000					
0029	0000					; print a string of characters terminated by a 0 byte
0030	0000					; on entry: X register holds location of string
0031	0000					
0032	0000		PRSTRNG	START		
0033	0000	BD0000	TOP	LDA	!0,X	get char at index position in string
0034	0003	F006		BEQ	DONE	if character is 0, return
0035	0005	200080		JSR	COUT	print character in accum
0036	0008	E8		INX		
0037	0009	80F5		BRA	TOP	
0038	000B	60	DONE	RTS		
0039	000C					
0040	000C			END		
0041	0000					
0042	0000					
0043	0000					; machine-dependent routine to output a character
0044	0000					
0045	0000		COUT	START		
0046	0000		ECOUT	GEQU	\$\$FDED	Apple // COUT
0047	0000	48		PHA		Save registers
0048	0001	DA		PHX		
0049	0002	5A		PHY		
0050	0003	08		PHP		and status,
0051	0004	38		SEC		switch to emulation
0052	0005	FB		XCE		
0053	0006	20EDFD		JSR	ECOUT	call 6502 routine
0054	0009	18		CLC		
0055	000A	FB		XCE		restore native mode
0056	000B	28		PLP		restore status
0057	000C	7A		PLY		restore register
0058	000D	FA		PLX		return
0059	000E	68		PLA		
0060	000F	60		RTS		
0061	0010			END		

Listing 12.3

## The Western Design Center

By loading the **X** register with the address of a string constant, the subroutine **PRSTRNG** has all the information it needs to print the string at that address each time it is called. The data at the address passed in a register could also be a more complex data structure than a string constant.

On the 6502 and 65C02, a sixteen-bit address has to be passed in two registers. Because of this, parameters are often passed in fixed memory locations. Typically, these might be direct page addresses. Listing 12.4 gives an example of this method.

0001	0000			KEEP	KL.12.4	
0002	0000					
0003	0000					
0004	0000				6502/65C02 example	
0005	0000					
0006	0000			PEX	START	
0007	0000					
0008	0000			PARAM	GEQU	\$80
0009	0000					
0010	0000	A200		LDX	#>STRING1	load high byte of STRING1's address
0011	0002	8681		STX	PARAM+1	store the high byte of direct page cell
0012	0004	A20C		LDX	#<STRING1	load low byte of STRING1's address
0013	0006	8680		STX	PARAM	store to low byte of direct page cell
0014	0008	2000080		JSR	PRSTRNG	print STRING1
0015	0008	60		RTS		
0016	000C					
0017	000C	54686973	STRING1	DC	C 'This is string one', H'00'	
0018	001F					
0019	001F			END		
0020	0000					
0021	0000				; print a string of characters terminated by a 0 byte	
0022	0000				; on entry: direct page location PARAM holds address of string	
0023	0000					
0024	0000			PRSTRNG	START	
0025	0000			COUT	GEQU	\$FDED Apple // output routine
0026	0000					
0027	0000	A000		LDY	#0	start at string position zero
0028	0002	B180	LOOP	LDA	(PARAM),Y	get char at index position in string
0029	0004	F006		BEQ	DONE	if character is 0, return
0030	0006	20EDFD		JSR	COUT	print character in accum
0031	0009	C8		INY		point to next char
0032	000A	D0F6		BNE	LOOP	loop thru string: must be < 256
0033	000C	60	DONE	RTS		
0034	000D					
0035	000D					
0036	000D			END		

**Listing 12.4**

Unfortunately, it takes eight bytes to set up **PARAM** each time **PRSTRNG** is called. As a result, a frequently used method of passing parameters to a subroutine is to code the data in-line, immediately following the subroutine call. This technique (*see* Fragment 12.5) uses no registers and no data memory, only program memory.



## The Western Design Center

0000		.		
0000		.		
0000	2000080	JSR	PRSTRNG	print the following string
0003	54686520	DC	C 'The string to be printed', H '00'	
001C		REUTRN	.	execution continues here
001C		.		
001C		.		
001C		.		
001C		.		

### Fragment 12.5

This method looks, at first glance, bizarre. Normally, when a subroutine returns to the calling section of code, the instruction immediately following the **JSR** is executed. Obviously, in this example, the data stored at that location is not executable code, but string data. Execution should resume instead at the label **RETURN**, which is exactly what happens using the **PRSTRNG** coded in Listing 12.5. The return address pushed onto the stack by the **JSR** is *not* a return address at all; it is, rather, the parameter to **PRSTRNG**.

## The Western Design Center

0001	0000			KEEP	KL.12.5	
0002	0000			65816	ON	
0003	0000					
0004	0000		PRSTRNG	START		
0005	0000					
0006	0000	18		CLC		
0007	0001	FB		XCE		
0008	0002					
0009	0002	E220		SEP	#\$20	8-bit accum
0010	0004			LONGA	OFF	
0011	0004					
0012	0004	C210		REP	#\$10	16-bit index regs
0013	0006			LONGI	ON	
0014	0006					
0015	0006	FA		PLX		pull return address
0016	0007	E8		INX		and increment to point JSR to string
0017	0008	BD0000	LOOP	LDA	!0,X	get char at index position in string
0018	000B	F006		BEQ	DONE	if character is 0, return
0019	000D	200080		JSR	COUT	print char in accum
0020	0010	E8		INX		point to next char
0021	0011	80F5		BRA	LOOP	loop thru string
0022	0013					
0023	0013					; push pointer to zero-terminator as return addr (RETURN-1)
0024	0013					
0025	0013	DA	DONE	PHX		
0026	0014	60		RTS		return to label RETURN
0027	0015			END		
0028	0000					
0029	0000					
0030	0000				COUT	
0031	0000					; machine-dependent routine to output a character
0032	0000					;
0033	0000				COUT	START
0034	0000		ECOUT	GEQU	SFDED	Apple // COUT
0035	000	48		PHA		Save registers
0036	0001	DA		PHX		
0037	0002	5A		PHY		
0038	0003	08		PHP		and status,
0039	0004	38		SEC		switch to emulation
0040	0005	FB		XCE		
0041	0006	20EDFD		JSR	ECOUT	call 6502 routine
0042	0009	18		CLC		
0043	000A	FB		XCE		restore native mode
0044	000B	28		PLP		restore status
0045	000C	7A		PLY		restore registers
0046	000D	FA		PLX		return
0047	000E	68		PLA		
0048	000F	60		RTS		
0049	0010			END		

**Listing 12.5**

The parameter address on the stack need only be pulled and incremented once, and the data can then be accessed in the same manner as in the foregoing example. Since the loop terminates when the zero end-of-string marker is reached, pushing its address in the **X** register onto the stack gives **RTS** a correct return, value – **RETURN-1** – the byte before the location where execution should resume. Note that the data bank is assumed to equal the program bank.

The advantage of this method is in bytes used: there is no need for any explicit parameter-passing by the calling code, and the **JSR** mechanism makes the required information available to the subroutine automatically. In fact, for most applications on all four 65x microprocessors, this method uses fewer bytes for passing a single parameter than any other.

One slight disadvantage of this method is that if the string is to be output more than once, it and its preceding **JSR** must be made into a subroutine that is called to output the string.

## The Western Design Center

A second disadvantage to this method comes in calling routines to which more than one parameter must be passed. This last example demonstrated how a parameter (the address of the string) can be implicitly passed on the stack. But there is no way to extend the principle so two parameters could be implicitly passed, for instance, to a routine that compares two strings. On the other hand, parameter can also be explicitly passed on the stack. The push effective address instructions and stack-relative addressing modes make this all the easier, as Fragment 12.6 and Listing 12.6 show.

0000	F40080	PEA	STRING1	push address of STRING1 onto stack
0003	F40080	PEA	STRING2	push address of STRING2 onto stack
0006	200080	JSR	COMPARE	compare the two
0009	.	.	.	return and continue processing
0009	.	.	.	
0009	.	.	.	

### Fragment 12.6

0001	0000		KEEP	KL.12.6	
0002	0000		65816	ON	
0003	0000				
0004	0000				; compare two strings of characters, each terminated by a 0 byte
0005	0000				; on entry: locs of strings are stacked just below the return addr
0006	0000				; on exit : carry clear if chars match up to len of shortest string
0007	0000				; else carry set for no match
0008	0000				
0009	0000		COMPARE	START	
0010	0000				
0011	0000	08	PHP		assume native mode; save status
0012	0001				
0013	0001	C210	REP	#\$10	
0014	0003		LONGI	ON	
0015	0003		SEP	#\$20	
0016	0005		LONGA	OFF	
0017	0005				
0018	0005	A00000	LDY	#0	
0019	0008	B303	LOOP	LDA	(3,S),Y get character from first string
0020	000A	F007		BEQ	PASS if zero, end of string: match
0021	000C	D305		CMP	(5,S),Y compare to corresponding char in 2 <sup>nd</sup> string
0022	000E	D006		BNE	FAIL branch if not equal; probably failure
0023	0010	C8		INY	else do next pair
0024	0011	80F5		BRA	LOOP
0025	0013				
0026	0013				
0027	0013				; matches shortest string: ok
0028	0013				
0029	0013	28	PASS	PLP	restore previous status
0030	0014	18		CLC	but clear carry
0031	0015	60		RTS	
0032	0016	B305			
0033	0016	F0F9	FAIL	LDA	(5,S),Y was last failure due to end of string2?
0034	0018	F0F9		BEQ	PASS yes; let it pass
0035	001A				
0036	001A	28		PLP	restore previous status
0037	001B	38		SEC	sorry, no good
0038	001C	60		RTS	
0039	001D				
0040	001D			END	

### Listing 12.6

This example, which compares two strings to see if they are equal up to the length of the shorter of the two strings, uses parameters that have been explicitly passed on the stack. This approach, since it explicitly passes the address of the strings, lets them be located anywhere and referred to any number of times. Its

## The Western Design Center

problem is that when the subroutine returns, the parameters are left on the stack. Clearly, the subroutine should clean up the stack before returning; however, it can't simply pull the parameters off, because the return address is sitting on top of the stack (which explains why stack offsets of three and five, rather than one and three, are used).

Perhaps the cleanest way to pass parameters on the stack prior to a subroutine call is to decompose the **JSR** instruction into two: one to push the return address, the other to transfer to the subroutine. The push effective address instructions again come in handy. Fragment 12.7 shows how the parameters to the routine in Listing 12.7 are passed.

0000		.		
0000		.		
0000	F4FF7F	PEA	RETURN-1	push return addr before parameters
0003	F40080	PEA	STRING1	push address of STRING1 onto stack
0006	F40080	PEA	STRING2	push address of STRING2 onto stack
0009	4C0080	JMP	COMPARE	compare them
000C	RETURN	.		continue processing
000C		.		
000C		.		
000C		.		

**Fragment 12.7**

0001	0000			KEEP	KL.12.7	
0002	0000			65816	ON	
0003	0000					
0004	0000					; compare two strings of characters, each terminated by a 0 byte
0005	0000					; on entry: locs of strings are at top of stack
0006	0000					; return address is stacked just beneath
0007	0000					; on exit: carry clear if chars match up to len of shortest string
0008	0000					; else carry set for no match
0009	0000					
0010	0000			COMPARE	START	
0011	0000					
0012	0000	08		PHP		assume native mode; save status
0013	0000					
0014	0001	C210		REP	#\$10	
0015	0003			LONGI	ON	
0016	0003					
0017	0003	E220		SEP	#\$20	
0018	0005			LONGA	OFF	
0019	0005					
0020	0005	A00000		LDY	#0	
0021	0008	B301	LOOP	LDA	(1,S),Y	get character from first string
0022	000A	F007		BEQ	PASS	if zero, end of string: match
0023	000C	D303		CMP	(3,S),Y	compare to corresponding char in 2 <sup>nd</sup> string
0024	000E	D007		BNE	FAIL	bra if not equal; probably failure
0025	0010	C8		INY		else do next pair
0026	0011	80F5		BRA	LOOP	
0027	0013					
0028	0013					; matches shortest string
0029	0013					
0030	0013	28	PASS	PLP		they match up to shortest string;
0031	0014	18		CLC		restore status, but clear carry
0032	0015	8006		BRA	EXIT	
0033	0017					
0034	0017	B303	FAIL	LDA	(3,S),Y	was last failure due to end of string2?
0035	0019	F0F8		BEQ	PASS	yes, let it pass
0036	001B	28		PLP		restore status, but set carry (no match)
0037	001C	38		SEC		
0038	001D					
0039	001D	FA	EXIT	PLX		clean up stack: remove both 16-bit params
0040	001E	FA		PLX		
0041	001F	60		RTS		now return
0042	0020					
0043	0020			END		

Listing 12.7

Since the return address was pushed first, the parameter addresses on the stack are accessed via offsets of one and three. Before returning, two pull instructions pop the parameters off the stack, then the **RTS** is executed, which returns control to the main program with the stack in order.

Passing parameters on the stack is particularly well suited for both recursive routines (routines that call themselves) and reentrant routines (routines that can be interrupted and used successfully both by the interrupting code and the original call) because new memory is automatically allocated for parameters for each invocation of the subroutine. This is the method generally used by most high-level languages that support recursion.

Fragment 12.8 sets up multiple parameters implicitly passed on the stack by coding after the **JSR**, not data, but pointers to data. The routine called is in Listing 12.8.

## The Western Design Center

0000		.		
0000		.		
0000	200080	JSR	COMPARE	compare two strings; addresses follow
0003	0080	DC	A 'STRING1'	address of STRING1
0005	0080	DC	A 'STRING2'	address of STRING2
0007		RETURN	.	continue processing
0007		.		
0007		.		
0007		.		

### Fragment 12.8

While this subroutine, unlike the previous one, uses a dozen bytes just getting itself ready to start, each call requires only seven bytes (three for the **JSR**, and two each for the parameters), while each call to the previous routine required twelve bytes (three **PERs** at three bytes each plus three for the **JMP**).

Apple Computer's ProDOS operating system takes this method a step further: all operating system routines are called via a **JSR** to a single ProDOS entry point. One of the parameters that follow the **JSR** specifies the routine to be called, the second parameter specifies the address of the routine's parameter block. This method allows the entry points of the internal ProDOS routines to "float" from one version of ProDOS to the next; user programs don't need to know where any given routine is located.

## The Western Design Center

0001	0000			KEEP	KL.12.8	
0002	0000			65816	ON	
0003	0000					
0004	0000					; compare two strings of characters, each terminated by a 0 byte
0005	0000					; on entry: increment address at top of stack: pts to loc of 1 <sup>st</sup> str
0006	0000					; incr twice more to point to loc of 2 <sup>nd</sup> str
0007	0000					
0008	0000			COMPARE	START	
0009	0000					
0010	0000	C210		REP	#\$10	caller must save and
0011	0002			LONGI	ON	restore mode status
0012	0002					
0013	0002	E220		SEP	#\$20	
0014	0004			LONGA	OFF	
0015	0004					
0016	0004	7A		PLY		
0017	0005	C8		INY		points to indirect address of 1 <sup>st</sup> str
0018	0006	B90000		LDA	!0,Y	load accum with address of 1 <sup>st</sup> string
0019	0009	C8		INY		
0020	000A	C8		INY		point Y to indirect addr of 2 <sup>nd</sup> string
0021	000B	BE0000		LDX	!0,Y	load X with address of 2 <sup>nd</sup> string
0022	000E	C8		INY		point Y to RETURN-1 for RTS
0023	000F	5A		PHY		and push it onto stack for RTS
0024	0010	A8		TAY		load Y with address of 1 <sup>st</sup> string
0025	0011					
0026	0011	B90000	LOOP	LDA	!0,Y	get character from first string
0027	0014	F009		BEQ	PASS	if zero, end of string: match
0028	0016	DD0000		CMP	!0,X	compare to corresponding char in 2 <sup>nd</sup> string
0029	0019	D006		BNE	FAIL	bra if not equal; probably failure
0030	001B	C8		INY		else do next pair
0031	001C	E8		INX		
0032	001D	80F2		BRA	LOOP	
0033	001F	18	PASS	CLC		they match up to shortest string;
0034	0020	60		RTS		
0035	0021	BD0000	FAIL	LDA	!0,X	was last failure due to end of string2?
0036	0024	F0F9		BEQ	PASS	yes; let it pass
0037	0026	38		SEC		sorry, no good
0038	0027	60	EXIT	RTS		now return!
0039	0028					
0040	0028			END		

Listing 12.8

# 13) Chapter Thirteen

## Interrupts and System Control Instructions

This is the last chapter that introduces new instructions; almost the entire 65816 instruction set, and all of the addressing modes, have been presented. The only instructions remaining are the interrupts and status register control instructions, listed in Table 13.1. This chapter introduces interrupt processing, as well.

Most of the system control functions described are of practical interest only if you are implementing systems programs for the 65x processors, such as operating systems or device handling routines. It is quite possible that if you are programming on an existing machine, with full operating system support, you will have little cause to use many of the system control instructions.

Mnemonic	Available on:			Description
	6502	65C02	65802/816	
BRK	x	x	x	Break (software interrupt)
RTI	x	x	x	Return from Interrupt
NOP	x	x	x	No operation
SEC	x	x	x	Set carry flag
CLC	x	x	x	Clear carry flag
SED	x	x	x	Set decimal mode
CLD	x	x	x	Clear decimal mode
SEI	x	x	x	Set interrupt disable flag
CLI	x	x	x	Clear interrupt disable flag
CLV	x	x	x	Clear overflow flag
SEP			x	Set status register bits
REP			x	Clear status register bits
COP			x	Co-processor or software interrupt
STP			x	Stop the clock
WAI			x	Wait for interrupt
WDM			x	Reserved for expansion

Table 13-1. Interrupt and System Control Instructions.

### Interrupts

An **interrupt**, as the name implies, is a disruption of the normal sequential flow of control, as modified by the flow-altering statements such as branches and jump instructions encountered in the stream of code.

**Hardware interrupts** are generated when an external device causes one of the interrupt pins, usually the **IRQ'** or **interrupt request** pin, to be electrically pulled low from its normally high signal level. The typical application of 65x interrupts is the implementation of an interrupt-driven I/O system, where input-output devices are allowed to operate **asynchronously** from the processor. This type of system is generally considered to be superior to the alternative type of I/O management system, where devices are polled at regular intervals to determine whether or not they are ready to send or receive data; in an interrupt-driven system, I/O service only claims processor time when an I/O operation is ready for service. Figure 13.1 illustrates how processor time is spent under either system.



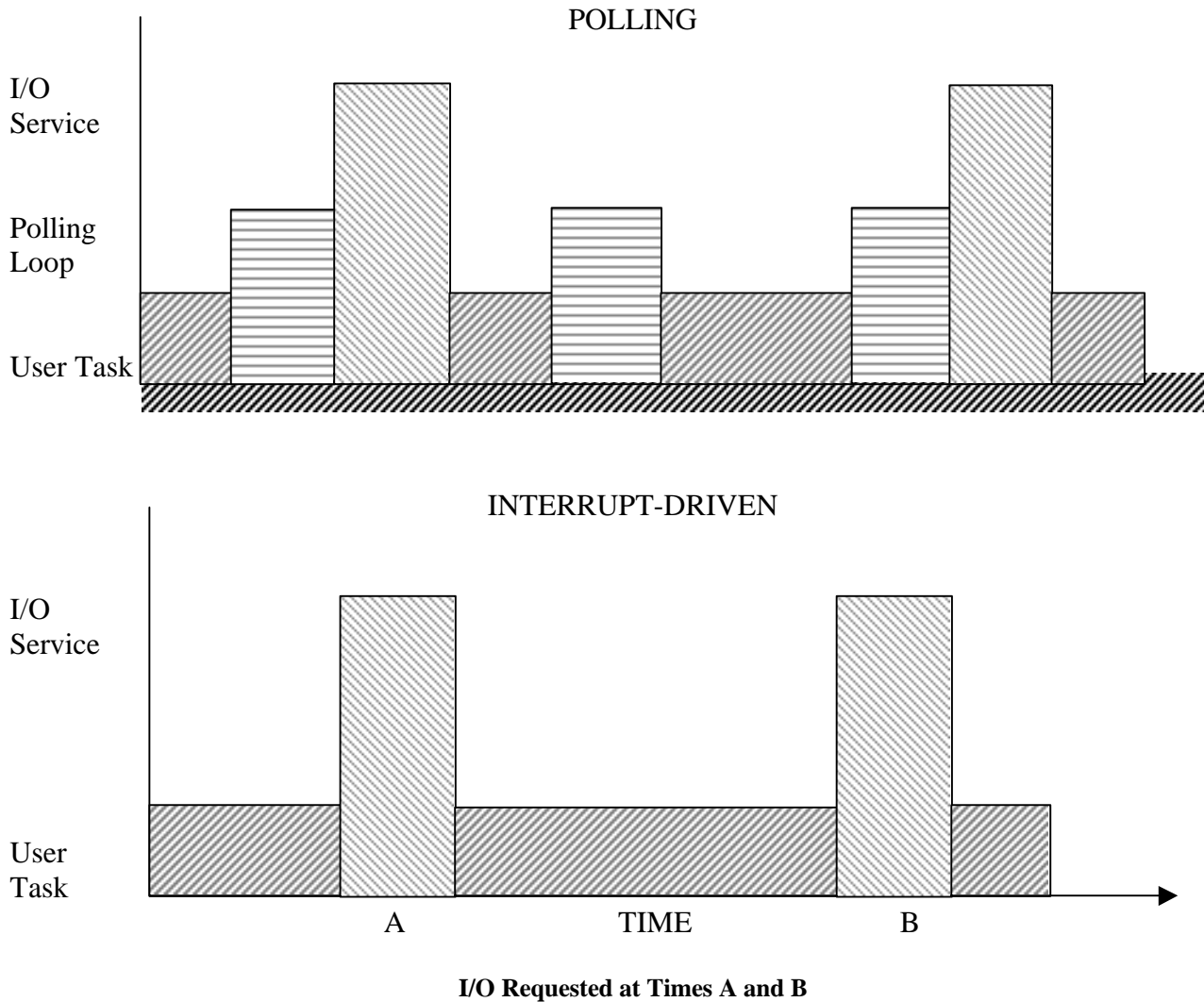

**Figure 13-1 I/O Management: Interrupts vs. Polling**

**Software interrupts** are special instructions that trigger the same type of system behavior as occurs during a hardware interrupt.

When an interrupt signal is received, the processor loads the program counter with the address stored in one of the sixteen-bit **interrupt vectors** in page \$FF of bank zero memory, jumping to the (bank zero) routine whose address is stored there. (In the case of the 6502, 65C02, and 65802, “bank zero” refers to the lone 64K bank memory addressable by these processors.) The routine that it finds there must determine the nature of the interrupt and handle it accordingly.

When an interrupt is first received, the processor finishes the currently executing instruction and pushes the double-byte program counter (which now points to the instruction following the one being executed when the interrupt was received) and the status flag byte onto the stack. Since the 6502 and 65C02 have only a sixteen-bit program counter, only a sixteen-bit program counter address is pushed onto the stack; naturally, this is the way the 65802 and 65816 behave when in emulation mode as well. The native-mode 65802 and 65816 must (and do) also push the program counter bank register, since it is changed to zero when control is transferred through the bank zero interrupt vectors.

As Figure 13.2 shows, in native mode the program bank is pushed onto the stack first, before the program counter and the status register: but emulation mode it is lost. This means that if a 65816 program is running in emulation mode in a bank other than zero when an interrupt occurs, there will be no way of knowing where to return to after the interrupt is processed because the original bank will have been lost.

**The Western Design Center**

This unavoidable but fairly esoteric problem can be dealt with in two ways. The first is simply never run in emulation mode outside bank zero. The second solution, which is to store the value of the program counter bank register in a known location before entering the emulation mode with a non-zero program counter bank register, is described later in this chapter.

In addition to pushing the status and program counter information onto the stack, the **d** decimal flag in the status register is cleared (except on the 6502), returning arithmetic to binary mode. The **i** interrupt disable flag is set, preventing further interrupts until your interrupt-service routine resets it (it may do this as soon as it is finished saving the previous context) or the routine is exited (with an **RTI** return-from-interrupt instruction). Indeed, if the interrupt flag had already been set, the first interrupt would have been ignored as well.

This last feature of disabling interrupts, however, does not apply to a second type of hardware interrupt, called the non-maskable interrupt (or **NMI'**) for the very reason that it cannot be ignored, even if the **i** flag is set. **NMI'** is triggered by a separate pin on a 65x processor; its use is usually reserved for a single high priority interrupt, such as power failure detection.

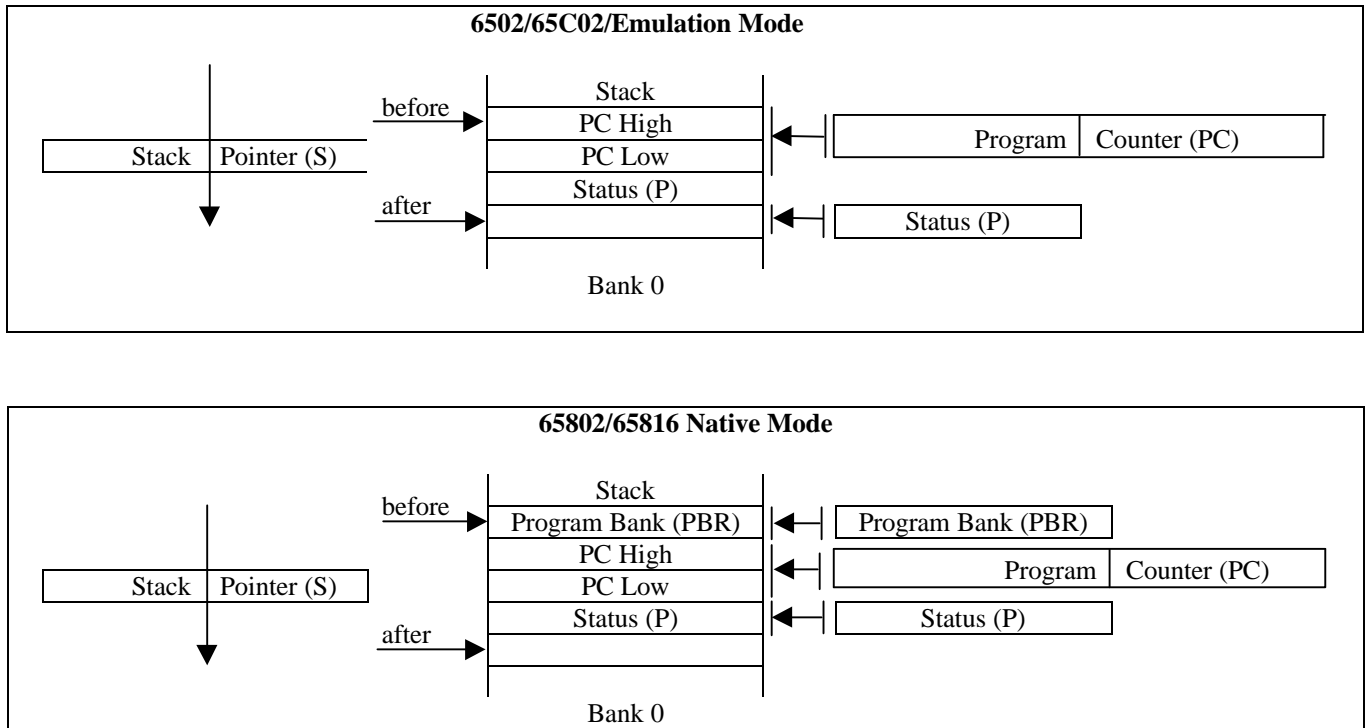

**Figure 13-2 Interrupt Processing**

Just as the two types of interrupt have their own signals and pins, they also have their own vectors – locations where the address of the interrupt-handling routine is stored. As Table 13.2 shows, on the 65802 and 65816 there are two sets of interrupt vectors: one set for when the processor is in emulation mode, and one set for when the processor is in native mode. Needless to say, the locations of the emulation mode vectors are identical to the locations of the 6502 and 65C02 vectors.

Emulation mode, e = 1	Native mode, e = 0
00FFFE,FF - IRQ/BRK	00FFEE,EF - IRQ
00FFFC,FD - RESET	-
00FFFA,FB - NMI	00FFEA,EB - NMI
00FFF8,F9 - ABORT	00FFE8,E9 - ABORT
	00FFE6,E7 - BRK
	00FFE4,E5 - COP

Table 13-2 Interrupt Vectors

As you can see in Table 13.2, there are several other vector locations named in addition to **IRQ'** and **NMI'**. Note that there is no native mode **RESET'** vector: **RESET'** always forces the processor to emulation mode. Also note that the **IRQ'** vector among the 6502 vectors is listed as **IRQ'/BRK**, while in the 65802/65816 native mode list, each has a separate vector.

The **BRK** and **COP** vectors are for handling **software interrupts**. A software interrupt is an instruction that imitates the behavior of a hardware interrupt by stacking the program counter and the status register, and then branching through a vector location. On the 6502 and 65C02, the location jumped to in response to the execution of a **BRK** (a software interrupt) and the location to which control is transferred after an **IRQ'** (a hardware interrupt) is the same; the interrupt routine itself must determine the source of the interrupt (that is, either software or hardware) by checking the value of bit five of the processor status register pushed onto the stack. On the 6502 and 65C02 (and the 6502 emulation mode of the 65802 and 65816), bit five is the **b** break flag. Note first that this is not true of the 65816 native mode, since bit five of its status register is the **m** memory select flag. Secondly, notice that it is the *stacked* status byte which must be checked, *not* the current status byte.

Suppose, for example, that the **IRQ'/BRK** vector at \$00:FFFE.FF contains the address \$B100 (naturally, in the low-high order all 65x addresses are stored in), and the code in Fragment 13.1 is stored starting at \$B100. When a **BRK** instruction is executed, this routine distinguishes it from a hardware interrupt and handles each uniquely.

```

0000                                ORG      $B100
0000
0000      IRQBRKIN      START
0000      8D1000      STA      SAVEA      save original accumulator
0003      68          PLA          copy p register
0004      48          PHA          return it to stack
0005      2920      AND      #%00010000  look at bit four only
0007      D0F7      BNE      ISBRK      bra if bit 4 set:
0009          ;                      BRK caused interrupt
0009          .                      else caused by IRQ"
0009          .
0009          .
0009          .
0009      4C0C00      JMP      RETURN    reload accum and return
000C
000C          ; handle interrupt caused by BRK instruction
000C
000C      ISBRK      .              do BRK handling code
000C          .
000C          .
000C      AD1000      RETURN   LDA      SAVEA      reload saved accumulator
000F      40          RTI          return
0010
0010      00          SAVEA      DS      1
0011
0011                                END

```

Fragment 13.1

## The Western Design Center

The **RTI**, or **return-from-interrupt** instruction is similar to the **RTS** (return-from-subroutine) instruction. **RTI** returns control to the location following the instruction that was interrupted by pulling the return address off the stack. Unlike the **RTS** instruction, however, since the status register was also pushed onto the stack in response to the interrupt, it too is restored, returning the system to its prior state. Further, in the 65802/65816 native mode the **RTI** instruction behaves like an **RTL** (return from subroutine long), in that the program counter bank register is also pulled off the stack. This difference makes it critical that the processor always be in the same state when the **RTI** instruction is executed as it was when it was interrupted. The fact that the 65816 has separate vector groups for native and emulation modes makes this easier to achieve.

There is another key difference between the **RTI** and the **RTS** or **RTL**: **RTS** and **RTL** increment the return address after pulling it off the stack and before loading it into the program counter; **RTI** on the other hand loads the program counter with the stack return address unchanged.

**RTI** will probably not function correctly in the special case where an interrupt occurred while code was executing in the emulation mode in a non-zero bank: **RTI** will try to return control to an address within the bank the **RTI** is executed in, which will probably not be the correct bank because (as on the 6502 and 65C02) the bank address is not stacked. As mentioned earlier, the only way to deal with this is to save the bank address prior to entering emulation mode. When the interrupt handler returns, it should use this saved bank address to execute a long jump to an **RTI** instruction stored somewhere within the return bank, the long jump will present the program bank address to the correct value before the **RTI** is executed.

The interrupt handler itself should enter the native mode if interrupts are to be reenabled before exiting in order to avoid the same problem, the return to emulation mode before exiting via the long jump to the **RTI** instruction.

Concerning the **BRK** instruction, you should also note that although its second byte is basically a “don’t care” byte – that is, it can have any value - the **BRK** (and **COP** instruction as well) is a two-byte instruction, the second byte sometimes is used as a **signature byte** to determine the nature of the **BRK** being executed. When an **RTI** instruction is executed, control always returns to the *second byte past* the **BRK** opcode. Figure 13.3 illustrates a stream of instructions in hexadecimal form, the **BRK** instruction, its signature byte, and location an **RTI** returns to. The **BRK** instruction has been inserted in the middle; after the **BRK** is processed by a routine (such as the skeleton of a routine described above), control will return to the **BCC** instruction, which is the second byte past the **BRK** opcode.

The fact that the opcode for the **BRK** instruction is 00 is directly related to one of its uses: **patching** existing programs. Patching is the process of inserting instruction data in the middle of an existing program in memory to modify (usually to correct) the program without reassembling it. This is a favored method of some programmers in debugging and testing assembly language programs, and is quite simple if you have a good machine-level monitor program that allows easy examination and modification of memory locations. However, if the program to be patched is stored in **PROM** (programmable read-only memory), the only way to modify a program that has already been “burned-in” is to change any remaining one bits to zeros. Once a **PROM** bit has been “blown” to zero, it cannot be restored to a one. The only way to modify the flow of control is to insert **BRK** instructions – all zeroes – at the patch location and to have the **BRK** handling routine take control from there.

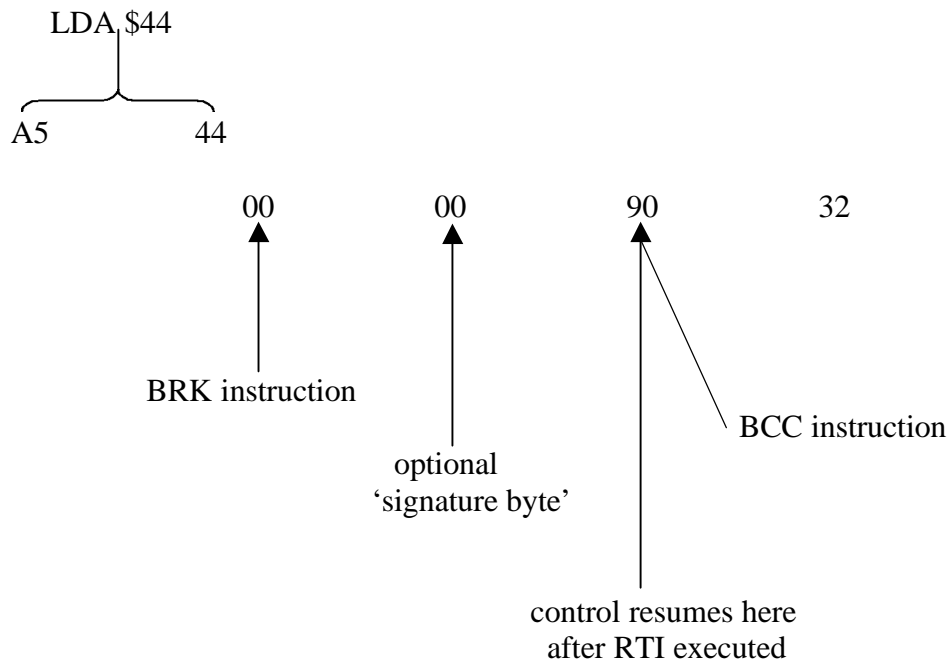

Figure 13-3 Break Signature Byte Illustration

### Processing Interrupts

Before an interrupt handling routine can perform a useful task, it must first know what is expected of it. The example of distinguishing a **BRK** from an **IRQ** is just a special case of the general problem of identifying the source of an interrupt. The fact that different vectors exist for different types of interrupts – for example, **NMI** would usually be reserved for some catastrophic type of interrupt, like “power failure imminent”, which demanded immediate response – solves the problem somewhat. Typically, however, in an interrupt-driven system there will be multiple sources of interrupts through a single vector. The 65802 and 65816, when in native mode, eliminate the need for a routine to distinguish between **IRQ** and **BRK**, such as the one above, by providing a separate **BRK** vector, as indicated in Table 13.2. Although this does simplify interrupt processing somewhat, it was done primarily to free up bit five in the status register to serve as the native memory select flag, which determines the size of the accumulator.

The interrupt source is generally determined by a software technique called **polling**: when an interrupt occurs, all of the devices that are known to be possible sources of interrupts are checked for an indication that they were the source of the interrupt. (I/O devices typically have a status bit for this purpose.) A hardware solution also exists, which is to externally modify the value that is apparently contained in the vector location depending on the source of interrupt. The 65816 aids the implementation of such systems by providing a **VECTOR PULL** signal, which is asserted whenever the interrupt vector memory locations are being accessed in response to an interrupt.

A simple example of the polling method could be found in a system that includes the 6522 Versatile Interface Adapter as one of its I/O controllers. The 6522 is a peripheral control IC designed for hardware compatibility with the 65x processor family. The 6522 includes two parallel I/O ports and two timer/counters. It can be programmed to generate interrupts in response to events such as hardware handshaking signals, indicating that data has been read or written to its I/O ports, or to respond to one of its countdown timers reaching zero. The 6522 contains sixteen different control and I/O registers, each of which is typically mapped to an adjacent address in the 65x memory space. When an interrupt occurs, the processor must poll the **interrupt flag register**, shown in Figure 13.4, to determine the cause of the interrupt.

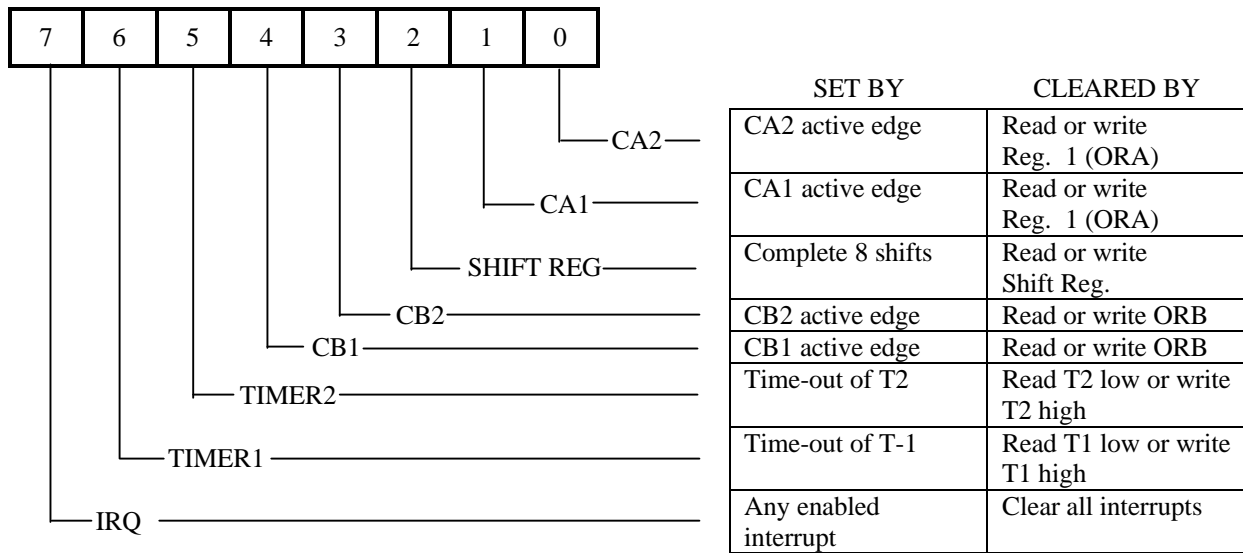

**Figure 13-4 6522 VIA Interrupt Flag Register**

If register zero of the 6522 is mapped to location \$FF:B080 of a 65816 system, for example, the interrupt flag register would normally be found at \$FF:B08D. The polling routine in Fragment 13.2 would be needed whenever an interrupt occurred. To keep the example simple, assume that only the two timer interrupts are enabled (for example, timer 1 to indicate, in a multi-tasking system, that a given process' time-slice has expired and the next process must be activated; timer 2, on the other hand, to maintain a time-of-day clock).

0000		IRQIN	START		
0000	E220		SEP	#\$20	8-bit accumulator
0002			LONGA	OFF	
0002					
0002	8D1B00		STA	SAVEA	save the accumulator
0005	AF8DB0FF		LDA	\$FFB08D	device interrupt register
0009	10F5		BPL	NEXTDEV	branch if bit 7 clear
000B	0A		ASL	A	check bits 6 & 5
000C	0A		ASL	A	bit 6 to carry, 5 to sign
000D	30F1		BMI	TIMER2	if 5 set, timer2 caused
000F					interrupt
000F					
000F					; timer2 didn't cause interrupt; timer1?
000F					
000F	90EF		BCC	ERROR	interrupt source unknown
0011					
0011					; bit 6 set: timer1 caused interrupt
0011					
0011		TIMER1	.		timer 1 handler code
0011			.		
0011			.		
0011					
0011	8004		BRA	RETURN	
0013					
0013					; bit 5 set: timer2 caused interrupt
0013					
0013		TIMER2	.		timer 2 handler code
0013			.		
0013			.		
0013	8002		BRA	RETURN	
0015					
0015					; interrupt not caused by 6522: check other devices
0015					
0015		NEXTDEV	.		code to poll next devices
0015			.		
0015			.		
0015	8000		BRA	RETURN	
0017					
0017		ERROR	.		error handling code
0017			.		
0017			.		
0017					
0017	AD1B00	RETURN	LDA	SAVEA	reload saved accumulator
001A	40		RTI		and return
001B					
001B	00	SAVEA	DS	1	
001C			END		

**Fragment 13.2**

When the interrupt flag register is loaded into the accumulator, the first thing to check is whether or not bit seven is set; bit seven is set if any 6522 interrupt is enabled. If it is clear, then the interrupt handler branches to the location **NEXTDEV**, which polls all other connected I/O devices looking for the interrupt.

If the 6522 was the source of the interrupt, then two shifts move the flag register's bit six into the carry and bit five into bit seven of the accumulator. Since bit five is set by the time-out of timer 2, if the high-order bit of the accumulator is set (minus), then the source of the interrupt must be timer 2. If timer 2 did not cause the interrupt, then the carry flag is checked; if it's set, then timer 1 caused the interrupt; if it's clear, then timer 1 didn't cause it either, so there has been some kind of error.

## The Western Design Center

Control is thus assigned to the correct routine to handle the specific source of interrupt.

It is important to note that in both examples in this chapter, the accumulator was saved in memory prior to its use within the interrupt-handling routine. You should further note that in the second example, which is specific to the 65816, only the low-order byte of the accumulator was stored, because the **STA SAVEA** instruction was executed after the **SEP #20** instruction, which set the accumulator size to eight bits. When the **RTI** instruction is executed at the end of the interrupt service routine, the **m** status flag will be restored to whatever value it had prior to the interrupt. If **m** was clear and the accumulator was in sixteen-bit mode, the high-order byte will have been preserved throughout the interrupt routine provided that none of the interrupt handling routines switch into sixteen-bit mode; if they do, the high-order part of the accumulator must be saved first, then restored before execution of the **RTI**.

An important concept related to interrupt handling is that of **reentrancy**; a reentrant program can be interrupted and literally reentered by the interrupt handling routine and return correct values for both the original invocation and the reentrant call from the interrupt handler. Reentrancy is normally achieved by using no addressable memory – only registers, which may be saved and restored on the stack each time the routine is entered. The stack relative addressing modes simplify the writing of reentrant routines considerably.

## Interrupt Response Time

By saving only the essentials – the program counter, program counter bank in 65802/65816 native mode, and status register – and shifting the burden of saving and restoring user registers (those that are actually used) to the programmer of the interrupt-handler, the 65x processors provide maximum flexibility and efficiency. It is quite possible for an interrupt routine to do useful work – such as checking the status of something within the system at periodic intervals – without using *any* registers.

At either seven or eight cycles per interrupt – the time required to stack the program counter, pc bank, and status register, and then jump through the interrupt vectors – the interrupt response cycle is among the longest-executing 65x instructions. Since an interrupt always lets the current instruction complete execution, there is a possible seven-cycle delay between the receipt of an interrupt and the servicing of one; this delay is called the **interrupt latency**. Small as the delay is, it can be significant in the servicing of data acquisition and control devices operating in real time, systems in which it is important that interrupts be disabled as little as possible.

It has been the goal of the designers of the 65x series to keep interrupt latency to a minimum. To further reduce interrupt latency, the 65802 and 65816 introduced a special new instruction, the **WAI** or **wait for interrupt** instruction. In an environment where the processor can be dedicated to serving interrupts – that is, where the interrupts provide timing or synchronization information, rather than being used to allow asynchronous I/O operations to be performed – the processor can be put into a special state where it sits and waits for an interrupt to happen. This lets any of the user registers be saved before the interrupt occurs, and eliminates the latency required to complete an existing instruction. Upon execution of a **WAI** instruction, the processor goes into a very low-power state, signals the outside world that it is waiting by pulling the bi-directional **RDY** signal low, and sits idle until an interrupt is received. When that occurs, response is immediate since no cycles are wasted completing an executing instruction.

There are two responses to an interrupt after the **WAI** instruction is executed. The first, as you might expect, is to release the waiting condition and transfer control to the appropriate interrupt vector, as normally takes place whenever interrupts are serviced. The second response is if maskable interrupts (on the **IRQ'** line) have been disabled, in which case the normal interrupt processing does not occur. However, since the waiting condition is released, execution continues with the instruction following the **WAI** opcode. This means that specialized interrupt-synchronization routines can be coded with a one-cycle latency between receipt of interrupt and response.

A second, similar 65802/65816 instruction is the **STP** or **stop the clock** instruction. The **STP** instruction reduces on-chip power consumption to a very low level by stopping the phase two clock input. Since power consumption of CMOS circuits increases with operating frequency, by halting the clock input the **STP** instruction is able to reduce the power consumption of the 65816 to its lowest possible value. Like the **WAI** instruction, the **STP** idles the processor after being executed. Further, the processor I/O buffers are disabled, making the bus available. The processor is powered back up in response to a **RESET'** signal being asserted.



## The Western Design Center

The **RESET**' pin is an input similar to the **IRQ**' and **NMI**' inputs. It is used to perform system initialization or reinitialization. When a 65x system is first powered up, **RESET**' must be asserted by external power-up circuitry. It can also be used to let the user force the system into a known state, for example, to break out of an infinite loop.

When **RESET**' is asserted, the processor is forced to emulation mode and the registers and status flags are initialized as shown in Table 13.3. Note that the initialization of the index register high bytes to zero is really a function of **x** being forced to one; **x** = 1 always clears the high byte of the index registers.

Stack High	01
Direct Page Register	0000
X Register High	00
Y Register High	00
Program Bank Register	00
Data Bank Register	00
Status Register	m = 1, x = 1, d = 0, i = 1
Emulation Flag	1

**Table 13-3 Reset Initialization**

In addition to the **BRK**, **IRQ**', **RESET**', and **NMI**' vectors discussed, there are two remaining interrupt-like vectors. These are the **COP** (co-processor) and **ABORT**' vectors. The **COP** vector is essentially a second software interrupt, similar to **BRK**, with its own vector. Although it can be used in a manner similar to **BRK**, it is intended particularly for use with co-processors, such as floating-point processors. Like **BRK**, it is a two-byte instruction with the second available as a signature byte.

The **ABORT**' vector contains the address of the routine which gains control when the 65816 **ABORT**' signal is asserted. Prior to transferring control through the **ABORT**' vector, the current instruction is completed but *no registers are modified*. The pc bank, program counter, and status register are pushed onto the stack in the same manner as an interrupt. The **ABORT**' signal itself is only available on the 65816; although the 65802 has an **ABORT**' vector, it is ineffective since no **ABORT**' signal can be generated because of the need for the 65802 to be pin-compatible with the 6502. Typical application of the abort instruction feature is the implementation of hardware memory-management schemes in more sophisticated 65816 systems. When a memory-bounds violation of some kind is detected by external logic, the **ABORT**' signal is asserted, letting the operating system attempt to correct the memory-management anomaly before resuming execution.

## Status Register Control Instruction

There are nine instructions that directly modify the flags of the status register; two of them are available only on the 65802 and 65816. These last two are the **SEP** (set the **P** status register) and **REP** (reset **P**) instructions, which you are already familiar with from their use in the example to set or reset the **m** and **x** flags in the status register. They can be used to set or clear any of the flags in the status register. For each bit in the immediate byte that follows the opcode, the corresponding bit in the status register is set or cleared (depending on whether **SEP** or **REP**, respectively, was used).

The other seven flag instructions set or clear individual flags in the status register. The pair **SEC** and **CLC** set and clear the carry flag when executed. These should be familiar to you from the chapter on arithmetic, where the **CLC** is always used before the first of a series of **ADC** instructions, and **SEC** before the first of a series of **SBC** instructions. Likewise, the **SED** and **CLD** modes should also be familiar from the same chapter's discussion of decimal-mode arithmetic; these two instructions set or clear the decimal mode. Note that reset can also affect the decimal flag: it is always initialized to zero on reset on the 65C02, 65802, and 65816; on the other hand, its value is indeterminate after reset on the 6502.

The **SEI** (set interrupt disable flag) and **CLI** (clear interrupt disable flag) instructions are new to this chapter: they are used to enable or disable the processor's response to interrupt requests via the **IRQ**' signal. If the **SEI** instruction has been executed, interrupts are disabled; a **CLI** interrupt instruction may be used to reenable interrupts. Note that the interrupt disable flag is set automatically in response to an interrupt request, whether a software interrupt or **IRQ**', **NMI**', or **RESET**'; this "locks out" other interrupts from occurring until

## The Western Design Center

the current one has been serviced. Similarly, the interrupt disable flag is cleared automatically upon return from an interrupt via **RTI** due to reloading of the stacked status register, which was pushed with **i** clear.

The **SEI** lets interrupts be locked out during critical routines which should not be interrupted. An example would be a device controller that depended on software timing loops for correct operation; interrupts must be locked out for the duration of the timing loop. It is important in an environment where interrupts are supported that they not be locked out for long periods of time. Although the **CLI** instruction will explicitly clear the interrupt disable flag, it is rarely used because typically the processor status is saved before execution of an **SEI** instruction as in Fragment 13.3, which reclears the flag by restoring the entire processor status register.

0000	08	PHP	save status
0001	78	SEI	disable interrupts
0002		.	
0002		.	execute time-critical code
0002		.	
0002	28	PLP	done – restore status, enable interrupts

**Fragment 13.3**

Since the interrupt disable flag was clear when the **PHP** instruction was executed, the **PLP** instruction restores the cleared flag. This same technique is also useful when mixing subroutine calls to routine with different default modes for accumulator and index register sizes; since saving the status with **PHP** is a common operation between subroutine calls anyway, the **PLP** instruction can be used to conveniently restore operating modes as well as status flags.

Finally, there is a **CLV** (clear overflow flag). There is no corresponding set overflow instruction, and, as you will recall from the chapter on arithmetic, the overflow flag does not need to be explicitly cleared before a signed operation. The arithmetic operation always change the overflow status to correctly reflect the result. The reason for including an explicit **CLV** instruction in the 65x repertoire is that the 6502, 65C02, and 65802 have a **SET OVERFLOW** input signal; external hardware logic can set the overflow flag of the status register by pulling the **SET OVERFLOW** input low. Since there is no corresponding clear overflow input signal, the overflow must be cleared in software in order to regain susceptibility to the **SET OVERFLOW** signal.

The practical application of the **SET OVERFLOW** signal is generally limited to dedicated control applications; it is rarely connected on general-purpose, 6502-based computer systems. On the 65816, there is no **SET OVERFLOW** input; it was sacrificed to make room for some of the more generally useful new signals available on the 65816 pin configuration.

## No Operation Instructions

The final two instructions to complete the 65816 instruction set are the no operation instruction. These do exactly what they sound like: nothing. They are used as place holders, or time-wasters; often they are used to patch out code during debugging. The **NOP** instruction – with a hexadecimal value of **\$EA** – is the standard no operation.

As mentioned in the earlier architecture chapters, the 6502 and 65C02 have a number of unimplemented instructions – the same opcodes which, on the 65802 and 65816, correspond to the new instructions. On the 6502, the operation of the processor when these “instructions” are executed is undefined; some of them cause the processor to “hang-up.” On the 65C02, these are all “well-behaved” no-operations of either one, two, or more cycles. On the 65802 and 65816, there is only one unimplemented instruction, defined as **WDM**; this is reserved for future systems as an **escape** prefix to expand the instruction set with sixteen-bit opcodes. For this reason, it should not be used in your current programs, as it will tend to make them incompatible with future generations of the 65816.

**Part 4**  
**Applications**

# 14) Chapter Fourteen

## Selected Code Samples

This chapter contains five different types of example programs, which are examined in detail. Each focuses on a different topic of interest to the 65x programmer: multiplication and division algorithms; a 65802-to-6502 mode-switching *tour de force*; a quick utility routine to determine which 65x processor a program is running under; high-level languages; and a popular performance benchmark.

### Multiplication

Probably the most common multiply routine written for eight-bit applications is to multiply one sixteen-bit number by another, returning a sixteen-bit result. While multiplying two large sixteen-bit numbers would yield a 32-bit result, much of systems programming is done with positive integers limited to sixteen bits, which is why this multiply example is so common. Be aware that a result over sixteen bits cannot be generated by the examples as coded – you’ll have to extend them if you need to handle larger numbers.

There are several methods for the sixteen-by-sixteen multiply, but all are based on the multiplication principles for multi-digit numbers you were taught in grade school: multiply the top number by the right-most digit of the bottom number; move left, digit by digit, through the bottom number, multiplying it by the top number, each time shifting the result product left one more space and adding it to the sum of the previous products:

$$\begin{array}{r} 2344 \\ \times \underline{12211} \\ 2344 \\ 2344 \\ 4688 \\ 4688 \\ \underline{2344} \\ 28622584 \end{array}$$

Or to better match the description:

$$\begin{array}{r} 2344 \\ \times \underline{12211} \\ 2344 \\ + \underline{2344} \\ 25784 \text{ sum of products so far} \\ + \underline{4688} \\ 494584 \text{ sum of products so far} \\ + \underline{4688} \\ 5182584 \text{ sum of products so far} \\ + \underline{2344} \\ 28622584 \text{ final product (sum of all single-digit multiplies)} \end{array}$$

## The Western Design Center

Binary multiplication is no different, except that, since each single-digit multiply is by zero or one, each resulting single-digit product is either the top number itself or all zeroes.

$$\begin{array}{r} 101 \\ \times 1010 \\ \hline 000 \\ 101 \\ 000 \\ \hline 101 \\ \hline 110010 \end{array}$$
$$\begin{array}{r} 5 \\ \times 10 \\ \hline 0 \\ \hline 5 \\ \hline 50 \text{ decimal} \end{array}$$

To have the computer do it, you have it shift the bottom operand right; if it shifts out a zero, you need do nothing, but if it shifts out a one, you add the top number to the partial product (which is initialized at zero). Then you shift the top number left for the possible add during the next time through this loop. When there are no more ones in the bottom number, you are done.

### ***6502 Multiplication***

With only three eight-bit registers, you can't pass two sixteen-bit operands to your multiply routine in registers. One solution, the one used below, is to pass one operand in two direct page (zero page) bytes, while passing the other in two more; the result is returned in two of the 6502's registers. All this is carefully documented in the header of the routine in Listing 14.1.

This 6502 multiply routine takes 33 bytes.

### ***65C02 Multiplication***

With the same three eight-bit registers as the 6502, and an instruction set only somewhat enhanced, the 65C02 multiply routine is virtually the same as the 6502s. Only one byte can be saved by the substitution of an unconditional branch instruction for the jump instruction, for a total byte count of 32.

### ***65802 and 65816 Multiplication***

The 65802 and 65816, when running in native mode, have three registers, all of which can be set to sixteen bits, in addition to having many more addressing modes. As you might expect, a multiply routine for these processors is considerably shorter than the 6502 and 65C02. What you might not expect is how much shorter: the multiply routine in Listing 14.2 for the 65802 and 65816 takes only 19 bytes – its length is less than 60 percent of each of the other two routines!

Notice the additional documentation at the beginning of the routine. The processor must have both its index registers and its accumulator in sixteen-bit modes *before* calling this routine.

The Western Design Center

0001	0000			KEEP	KL.14.1	
0002	0000					
0003	0000					
0004	0000					; 16 by 16 = 16-bit multiply for 6502 microprocessor
0005	0000					; operand 1: sixteen bits in direct page loc MCAND1/MCAND1+1
0006	0000					; operand 2: sixteen bits in direct page loc MCAND2/MCAND2+2
0007	0000					; result: returned in X-Y (hi - lo)
0008	0000					; all original register values are destroyed
0009	0000					
0010	0000		MULT	START		
0011	0000		MCAND1	GEQU	\$80	
0012	0000		MCAND2	GEQU	\$82	
0013	0000					
0014	0000	A200		LDX	#0	initialize result (hi)
0015	0002	A000		LDY	#0	initialize result (lo)
0016	0004					
0017	0004	A580	MULT1	LDA	MCAND1	operand 1 (lo)
0018	0006	0581		ORA	MCAND1+1	operand hi (hi); if 16-bit operand 1 is 0, done
0019	0008	F016		BEQ	DONE	
0020	000A	4681		LSR	MCAND1+1	get right bit, operand 1
0021	000C	6680		ROR	MCAND1	
0022	000E	9909		BCC	MULT2	if clear, no addition to previous products
0023	0010	18		CLC		else add oprd 2 to partial result
0024	0011	98		TYA		
0025	0012	6582		ADC	MCAND2	
0026	0014	A8		TAY		
0027	0015	8A		TXA		
0028	0016	6583		ADC	MCAND2+1	
0029	0018	AA		TAX		
0030	0019					
0031	0019	0682	MULT2	ASL	MCAND2	now shift oprd 2 left for poss. add next iteration
0032	001B	2683		ROL	MCAND2+1	
0033	001D	4C0400		JMP	MULT1	
0034	0020					
0035	0020	60	DONE	RTS		
0036	0021					
0037	0021			END		

Listing 14.1

The Western Design Center

0001	0000			KEEP	KL.14.2.	
0002	0000			65816	ON	
0003	0000					
0004	0000					; 16 by 16 = 16 multiply
0005	0000					; for 65802/65816 microprocessors in native mode with
0006	0000					; index registers and accumulator already set to 16 bits
0007	0000					; operand 1: sixteen bits in direct page location MCAND1
0008	0000					; operand 2: sixteen bits in direct page location MCAND2
0009	0000					; result: sixteen bits returned in accumulator
0010	0000					
0011	0000			MULT	START	
0012	0000			MCAND1	GEQU	\$80
0013	0000			MCAND2	GEQU	\$82
0014	0000					
0015	0000	18		CLC		
0016	0001	FB		XCE		
0017	0002	C230		REP		#\$30
0018	0004					
0019	0004			LONGA	ON	tell assembler about
0020	0004			LONGI	ON	index & accum settings
0021	0004					
0022	0004	A90000		LDA	#0	initialize result
0023	0007					
0024	0007	A680	MULT1	LDX	MCAND1	get operand 1
0025	0009	F00B		BEQ	DONE	if operand 1 is zero, done
0026	000B	4680		LSR	MCAND1	get right bit, operand 1
0027	000D	9003		BCC	MULT2	if clear, no addition to previous products
0028	000F	18		CLC		else add oprd 2 to partial result
0029	0010	6582		ADC	MCAND2	
0030	0012					
0031	0012	0682	MULT2	ASL	MCAND2	now shift oprd 2 left for poss add next time
0032	0014	80F1		BRA	MULT1	
0033	0016					
0034	0016	38	DONE	SEC		
0035	0017	FB		XCE		
0036	0018	60		RTS		
0037	0019			END		

Listing 14.2

## The Western Design Center

Along the same lines, notice that the first two lines of the subroutine are the mode directives – **LONGA ON** and **LONGI ON** – which inform the assembler that all three registers have been set to sixteen bits. That way, when the accumulator is loaded with immediate zero, the assembler will generate a sixteen-bit operand rather than an incorrect eight-bit one, which would cause program failure when executed.

The **RTS** instruction is the intra-bank return instruction. An **RTL** instruction could be substituted if the subroutine were intended to be called *only* by long jump-to-subroutine instructions, whether by code outside the bank or by code within it. You should document such a requirement in the routine's introductory comments.

## Division

Probably the most common division routine written for eight-bit applications is the converse of the multiply routine just covered – to divide one sixteen-bit number by another sixteen-bit number, returning both a sixteen-bit quotient and a sixteen-bit remainder.

There are several methods for doing this, but all are based on the division principles for multi-digit numbers that you learned in grade school. Line up the divisor under the left-most set of digits of the dividend, appending an imaginary set of zeroes out to the right, and subtract as many times as possible. Record the number of successful subtractions; then shift the divisor right one place and continue until the divisor is flush right with the dividend, and no more subtractions are possible. Any non-subtractable value remaining is called the remainder.

$$\begin{array}{r} \phantom{2344} \overline{) 28622585} \quad \text{12211 remainder 1} \\ \underline{-2344} \phantom{000000} \\ 5182585 \\ \underline{-2344} \phantom{00000} \\ 2838585 \\ \underline{-2344} \phantom{0000} \\ 494585 \\ \underline{-2344} \phantom{000} \\ 260185 \\ \underline{-2344} \phantom{00} \\ 25785 \\ \underline{-2344} \phantom{0} \\ 2345 \\ \underline{-2344} \\ 1 \end{array}$$

Binary division is even easier since, with only ones and zeroes, subtraction is possible at each digit position either only once or not at all:

$$\begin{array}{r} \phantom{101} \overline{) 111101} \quad \text{1100 remainder 1} \\ \underline{-101} \phantom{0000} \\ 10101 \\ \underline{-101} \phantom{00} \\ 01 \end{array} \qquad \begin{array}{r} \phantom{5} \overline{) 61} \quad \text{12 remainder 1} \\ \underline{-5} \phantom{0} \\ 11 \\ \underline{-5} \phantom{0} \\ 6 \\ \underline{-5} \\ 1 \end{array}$$



## The Western Design Center

Many programs calling this division routine will need only the quotient or only the remainder, although some will require both. The routines here return both.

### *6502 Division*

The 6502, with its three eight-bit registers, handles passing parameters to and from a division routine even less smoothly than to and from a multiplication routine: not only do you need to pass it two sixteen-bit values, but it needs to pass back two sixteen-bit results.

The solution used in Listing 14.3 is to pass the dividend and the divisor in two direct page double bytes, then pass back the remainder in a direct page double byte and the quotient in two registers.

## The Western Design Center

0001	0000		KEEP	KL.14.3.	
0002	0000				
0003	0000				
0004	0000				; 16 divided by 16 = 16 divide for 6502 microprocessor
0005	0000				; divide DIVDND / DIVSOR →XA (hi – lo); remainder in DIVDND
0006	0000				; DIVDND and DIVSOR are direct page double byte cells
0007	0000				; no special handling for divided by zero (returns \$FFFF quotient)
0008	0000				
0009	0000		DIV	START	
0010	0000		DIVDND	GEQU	\$80
0011	0000		DIVSOR	GEQU	\$82
0012	0000				
0013	0000				
0014	0002	A900	LDA	#0	
0015	0003	AA	TAX		initialize quotient (hi)
0016	0004	48	PHA		initialize quotient (lo)
0017	0006	A001	LDY	#1	initialize shift count = 1
0018	0008	A582	LDA	DIVSOR	get high byte of divisor
0019	000A	300B	BMI	DIV2	bra if divisor can't be shifted left
0020	000A	C8	DIV1	INY	else shift divisor to leftmost position
0021	000B	0682	ASL	DIVSOR	
0022	000D	2683	ROL	DIVSOR+1	test divisor
0023	000F	3004	BMI	DIV2	done if divisor in leftmost position
0024	0011	C011	CPY	#17	max count (all zeroes in divisor)
0025	0013	D0F5	BNE	DIV1	loop if not done
0026	0015				
0027	0015	38	DIV2	SEC	now do division by subtraction
0028	0016	A580	LDA	DIVDND	subtract divisor from dividend
0029	0018	E582	SBC	DIVSOR	low bytes first
0030	001A	48	PHA		save to difference temporarily on stack
0031	001B	A581	LDA	DIVDND+1	then subtract high bytes
0032	001D	E583	SBC	DIVSOR+1	
0033	001F	E583	BCC	DIV3	bra if can't subtract divisor from dividend
0034	0021				; else carry is set to shift into quotient
0035	0021	8581	STA	DIVDND+1	store high byte of difference
0036	0023	68	PLA		get low subtract result from stack
0037	0024	8580	STA	DIVDND	
0038	0026	48	PHA		restore low subtract result →stack for pull
0039	0027	68	DIV3	PLA	throw away low subtract result
0040	0028	68	PLA		bet quotient low byte from stack
0041	0029	2A	ROL	A	shift carry →quotient (1 for divide, 0 for not)
0042	002A	48	PHA		put back on stack
0043	002B	8A	TXA		get quotient high byte
0044	002C	2A	ROL	A	continue shift →quotient (high)
0045	002D	AA	TAX		put back in x
0046	002E	4683	LSR	DIVSOR+1	shift divisor right for next subtract
0047	0030	6682	ROR	DIVSOR	
0048	0032	88	DEY		decrement count
0049	0033	D0E0	BNE	DIV2	branch unless done (count is 0)
0050	0035				
0051	0035	68	DONE	PLA	get quotient (lo)
0052	0036	60		RTS	
0053	0037				
0054	0037			END	

Listing 14.3

## The Western Design Center

The label **DONE** is not needed (there is no branch to the location), but was added for clarity.

The routine at **DIV2** may seem curious. The 6502 has no sixteen-bit compare; to compare two sixteen-bit numbers, you must actually subtract them (setting the carry first, as is required before a subtract using the 65x **SBC** instruction). So the divisor is subtracted from the dividend, with the low result saved on the stack. If the carry is clear, the divisor is too large to be subtracted from the dividend. Thus a branch is taken to **DIV3**, where the low result is pulled but not used and the cleared carry is rolled into the quotient to acknowledge the unsuccessful subtraction. If the carry is set, then the high result, still in the accumulator, is stored, and the low result is pulled from the stack, stored, then restacked to be repulled at **DIV3**; since the carry is known to be set, it does not need to be explicitly set before rolling it into the quotient to acknowledge the successful subtraction.

The quotient is returned in register **X** and **A**.

This 6502 divide routine takes 55 bytes.

### 65C02 Division

The 65C02 routine is virtually the same; only three early instructions (shown in Fragment 14.1) in the 6502 routine are changed to the code in Fragment 14.2, for a net savings of one byte, because the 65C02 has instructions to push the index registers. This 65C02 divide routine takes 54 bytes, one byte fewer than the 6502 divide routine takes.

0000	A900	LDA	#0
0002	AA	TAX	
0003	48	PHA	

**Fragment 14.1**

0000	A200	LDX	#0
0002	DA	PHX	

**Fragment 14.2**

### 65802/65816 Division

The 65802 and 65816 processors, with their registers extendable to sixteen bits, can handle sixteen-bit division with ease. In the divide routine in Listing 14.4, the dividend and the divisor are passed in sixteen-bit registers **X** and **A** respectively; the quotient is passed back in a sixteen-bit direct page location and the remainder in **X**.

The Western Design Center

0001	0000			KEEP	KL.14.4	
0002	0000			65816	ON	
0003	0000					
0004	0000					; 16 divided by 16 = 16 divide for 65802/65816 microprocessor
0005	0000					; 16-bit divide: X /A →QUOTNT; remainder in X
0006	0000					; QUOTNT is a 16-bit direct page cell
0007	0000					; native mode: all registers set to 16-bit modes
0008	0000					; no special handling for divide by zero (returns \$FFFF quotient)
0009	0000					
0010	0000			DIV	START	
0011	0000			QUOTNT	GEQU	\$80
0012	0000					
0013	0001					
0014	0002					
0015	0004					
0016	0004			LONGA	ON	tell assembler about 16-bit
0017	0004			LONGI	ON	index & accumulator setting
0018	0004					
0019	0004	6480		STZ	QUOTNT	initialize quotient to 0
0020	0006	A00100		LDY	#1	initialize shift count to 1
0021	0009					
0022	0009	0A	DIV1	ASL	A	shift divisor: test leftmost bit
0023	000A	B006		BCS	DIV2	branch when get leftmost bit
0024	000C	C8		INY		else increment shift count
0025	000D	C01100		CPY	#17	max count (all zeroes in divisor)
0026	0010	D0F7		BNE	DIV1	loop if not done
0027	0012					
0028	0012	6A	DIV2	ROR	A	put shifted-out bit back
0029	0013					
0030	0013					; now divide by subtraction
0031	0013	48	DIV4	PHA		push divisor
0032	0014	8A		TXA		get dividend into accumulator
0033	0015	38		SEC		
0034	0016	E301		SBC	1,S	subtract divisor from dividend
0035	0018	9001		BCC	DIV3	bra if can't subtract; dividend still in X
0036	001A	AA		TAX		store new dividend; carry=1 for quotient
0037	001B					
0038	001B	2680	DIV3	ROL	QUOTNT	shift carry →quotient (1 for divide, 0 for not)
0039	001D	68		PLA		pull divisor
0040	001E	4A		LSR	A	shift divisor right for next subtract
0041	001F	88		DEY	DIV4	decrement count
0042	0020	D0F1		BNE		branch to repeat unless count is 0
0043	0022					
0044	0022					
0045	0023					
0046	0024	60		RTS		
0047	0025			END		

Listing 14.4.

## The Western Design Center

This divide routine for the 65802 and 65816 generates only 31 bytes, little more than half the bytes the 6502 and 65C02 divide routines generate.

As the introductory comments note, it requires the processor to be in native mode and the **m** and **x** memory select flags to be in sixteen-bit modes *before* the routine is called; these requirements become doubly obvious when you see in another of the comments that the values passed in the accumulator and an index register are sixteen bits, with one of the two sixteen-bit results being passed back in one of the same registers. Assemblers, however, do not read comments; they only read instructions and directives. That's the reason for the **LONGA ON** and **LONGI ON** directives at the beginning of the routine.

### Calling an Arbitrary 6502 Routine

Particularly during the early phases of the processor's life cycle, you might wish to mix existing 6502 code with your 65816 applications. The routine provided below provides a general purpose way of doing this. Additionally, the context-saving code illustrated here could prove useful in other applications. You'll find similar code in the debugger in the next chapter, where it is needed to save the context between instructions of the user program being traced.

The simplest way to call a 6502 routine from the 65802 or 65816 is found in Fragment 14.3.

0000	38	SEC	
0001	FB	XCE	
0002	200080	JSR	D06502

#### Fragment 14.3

Although this will work fine in *some* cases, it is not guaranteed to. In order to be assured of correct functioning of an existing 6502 routine, the direct page register must be reset to zero and the stack pointer must be relocated to page one. Although a 6502 program that uses zero page addressing will technically function correctly if the direct page has been relocated, the possibility that the zero page may be addressed using some form of absolute addressing, not to mention the probability that an existing 6502 monitor or operating system routine would expect to use values previously initialized and stored in the zero page, requires that this register be given its default 6502 value.

If the stack has been relocated from page one, it will be lost when the switch to emulation mode substitutes the mandatory stack high byte of one. So first, the sixteen-bit stack pointer must be saved. Second, if the 65802/65816 program was called from a 6502 environment, then there may be 6502 values on the original 6502 page-one stack; such a program must squirrel away the 6502 stack pointer on entry so it can be restored on exit, as well as used during temporary incursions, such as this routine, into the 6502 environment.

The goal, then, is this: provide a mechanism whereby a programmer may simply pass the address of a resident 6502 routine and any registers required for the call to a utility which will transfer control to the 6502 routine; the registers should be returned with their original (potentially sixteen-bits) values intact, except as modified by the 6502 routine; and finally the operating mode must be restored to its state before the call.

When loading the registers with any needed parameters, keep in mind that only the low-order values will be passed to a 6502 subroutine, even though this routine may be entered from either eight- or sixteen-bit modes.

The call itself is simple; you push the address of the routine to be called, *minus one*, onto the stack, typically using the **PEA** instruction. Then you call the routine, which executes the subroutine call and manages all of the necessary housekeeping. Fragment 14.4 gives an example of calling the routine.

## The Western Design Center

0000	A94100	LDA	#'A'	character to be printed
0003	F4ECFD	PEA	\$FDED-1	routine to be called
0006	200080	JSR	JSR6502	

### Fragment 14.4

\$FDED is the address of an existing Apple I I routine to print characters, and **JSR6502** is the routine described in Listing 14.5.

## The Western Design Center

0001	0000		KEEP	KL.14.5	
0002	0000		65816	ON	
0003	0000				
0004	0000	JSR6502	START		
0005	0000				
0006	0000				
0007	0000				; used by 65816 program called by 6502 code before moving stack
0008	0000				
0009	0000	08	PHP		save flags, including register sizes
0010	0001				
0011	0001	C230	REP	#\$30	set all registers to 16 bits
0012	0003		LONGA	ON	
0013	0003		LONGI	ON	
0014	0003				
0015	0003	DA	PHX		then push them
0016	0004	5A	PHY		push index regs
0017	0005	0B	PHD		push direct page base
0018	0006	48	PHA		push accum
0019	0007				
0020	0007				; set up page-1 stack ptr, saving 65802 stack ptr in DP & on new stack
0021	0007	38	TSC		save old stack pointer in
0022	0008	5B	TCD		direct page register
0023	0009	2900FF	AND	#\$FF00	mask stack pointer to examine high byte
0024	000C	C90001	CMP	#\$100	
0025	000F	F004	BEQ	USESTK	branch if stack already in page 1
0026	0011	AD4F00	LDA	STK6502	else retrieve safe 6502 stack pointer
0027	0014	1B	TCS		and load stack pointer with it
0028	0015	0B	USESTK	PHD	push old stack pointer onto new stack
0029	0016				
0030	0016				; set up a return-to-this-code return address on new stack
0031	0016				; (direct page register points to old stack with orig accum at 1)
0032	0016				
0033	0016	F42700	PEA	RETURN-1	push local return address (out exit code)
0034	0019	D40C	PEI	(12)	push routine addr from prev stack onto this one
0035	001B	A50A	LDA	10	shuffle return address
0036	001D	850C	STA	12	to bottom of old stack
0037	001F	A501	LDA	1	restore accum from prev stack using dp reg
0038	0021				
0039	0021				; set direct page to zero page
0040	0021	F40000	PEA	0	set direct page
0041	0024	2B	PLD		to zero page
0042	0025				
0043	0025				; switch to emulation mode
0044	0025	38	SEC		
0045	0026	FB	XCE		switch to emulation mode
0046	0027		LONGA	OFF	
0047	0027		LONGI	OFF	
0048	0027				
0049	0027				; and call 6502 routine
0050	0027	60	RTS		JSR (via RTS) to 6502 routine @ stacked addr
0051	0028				
0052	0028				;
0053	0028				; 6502 routine returns here
0054	0028	08	RETURN	PHP	now save returned flag results from 6502 code
0055	0029	EB	XBA		save returned A accum in B accum
0056	002A	68	PLA		get flags into A accum
0057	002B	2B	PLD		get old stack pointer
0058	002C				
0059	002C				; address old stack values as direct page:
0060	002C				; dp (stack) offset 12.13 = return address back to 65802/65816 code
0061	002C				; 10.11 = unused (orig held addr of 6502 routine)
0062	002C				; 9 = orig P flags
0063	002C				; 7.8 = orig 16-bit X
0064	002C				; 5.6 = orig 16-bit Y
0065	002C				; 3.4 = orig DP
0066	002C				; 1.2 = orig 16-bit accum

## The Western Design Center

0067	002C				0 = was next available stack location
0068	002C				
0069	002C				; combine returned condition flags with 65802/816 mode flags
0070	002C	29CF	AND	11001111	mask out m & x flags
0071	002E	850B	STA	11	save for a minute; dp:11 is free
0072	0030	A509	LDA	9	get orig P value
0073	0032	2930	AND	00110000	mask out all but m & x flags
0074	0034	050B	ORA	11	combine new condition flags with old m & x
0075	0036	850B	STA	11	store new P @ 11
0076	0038				; 9.10 in old stack now free
0077	0038				
0078	0038				; save registers returned from 6502 routine
0079	0038	EB	XBA		swap: 6502 accum back to A
0080	0039	8501	STA	1	save returned accumulator low
0081	003B	8405	STY	5	save returned Y low
0082	003D	8607	STX	7	save returned X low
0083	003F				
0084	003F	18	CLC		
0085	0040	FB	XCE		restore native mode
0086	0041				
0087	0041	C230	REP	#\$30	extend register size back to 16 bits
0088	0043		LONGA	ON	
0089	0043		LONGI	ON	
0090	0043				
0091	0043	0B	PHD		
0092	0044	FA	PLX		
0093	0045	9A	TXS		restore old stack pointer
0094	0046				
0095	0046				; but still address old stack via direct page
0096	0046				
0097	0046	68	PLA		copy accum to free stack bytes @ dp:9.10.
0098	0047	8509	STA	9	
0099	0049				; stack was moved by PLA, but DP was not
0100	0049				
0101	0049				; pull registers from stack
0102	0049	2B	PLD		restore old direct page
0103	004A	7A	PLY		
0104	004B	FA	PLX		
0105	004C	68	PLA		load accumulator again
0106	004D	28	PLP		get 6502 condition flags; 65802/816 modes
0107	004E				
0108	004E	60	RTS		done!
0109	004F				
0110	004F	8001	STK6502	DC	A'\$180'
0111	0051				arbitrary 'safe' stack in page one
0112	0051				smart user will store last page one
0113	0051				stack value here before switching stack
0114	0051				out of page one
0115	0051		END		

Listing 14.5

The routine is entered with the return address on the top of the stack, and the go-to address of the 6502 routine at the next location on the stack. Since you want to be able to restore the **m** and **x** mode flags, the first thing the routine does is push the status register onto the stack. The **REP #\$30** instruction, which follows, puts the processor into a known state, since the routine can be called from any of the four possible register-size modes. The long accumulator, long index mode is the obvious choice because it encompasses all the others. The user registers, including the direct page register, are saved on the stack, and then the stack pointer itself is saved to the direct page register via the accumulator. This has two benefits: it preserves the value of the old stack pointer across a relocation of the stack, and provides a means of accessing all of the data on the old stack after it has been relocated. This technique is of general usefulness, and should be understood clearly. Figure 14.1, which shows the state of the machine after line 0034 (the PEI instruction), helps make this clear.

The stack must be relocated to page one only if it is not already there. If it is elsewhere, then the last 6502 page-one stack pointer should be restored from where it was cubbyholed when the 65802/65816 program



## The Western Design Center

took control and moved the stack elsewhere. If there is no previous 6502 stack to avoid, any page one address could be used to initialize the temporary 6502 stack needed.

The first item that goes onto the new stack is the value of the old stack pointer, now found in the direct page register. Next, a local return address must be pushed on the stack for when the called 6502 routine executes an **RTS**.

While the direct page register was pushed onto the new stack, it retains its value, and still points to the old stack; so although the stack pointer has been relocated, you still have access to the values on the old stack via direct page addressing. One of the needed items is the go-to address, the address of the 6502 routine to be called. Since the size of all of the elements pushed on the stack is known, by referencing the direct page location 12, this value is retrieved. A **PEI** (push indirect) instruction is used to transfer the routine to be called from the old stack (now being referenced via the direct page) to the new stack. This frees up the double byte on the old stack dp:12.13, the bottom of the old stack; the return address is shuffled in from dp:10.11, freeing those two bytes.

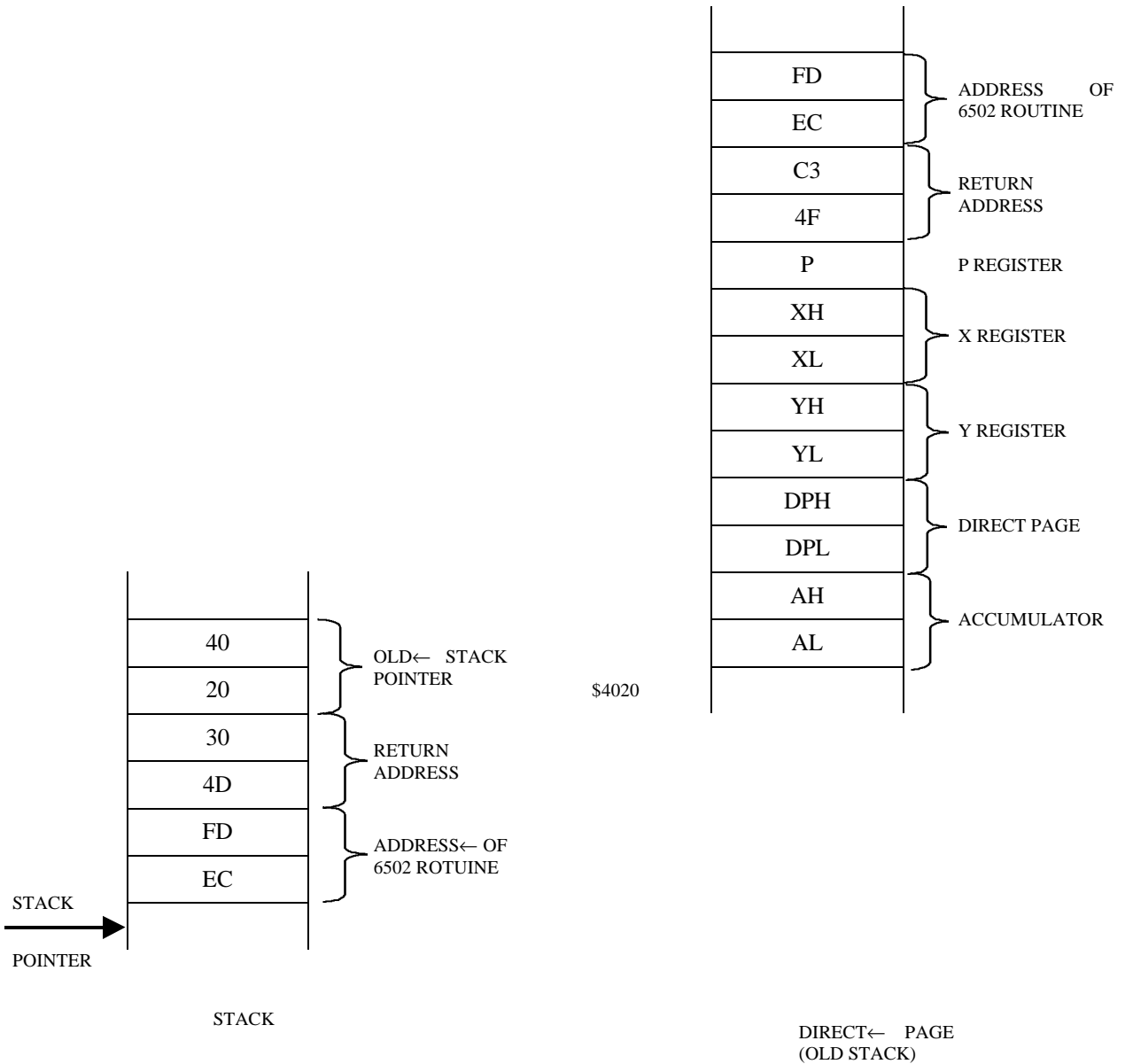

**Figure 14-1 Stack Snapshot after PEI (12) Instruction**

The accumulator was used during these operations, and must be restored because it may contain one of the parameters required by the 6502 routine. Like the go-to address, the accumulator is loaded from the old stack using direct page addressing.

Having restored the accumulator, all that remains is to set the direct page register to zero; since no registers can be modified at this point, this is accomplished by pushing a zero onto the stack, and then pulling it into the direct page register.

When you switch the processor into emulation mode, the environment is as it should be; the new stack is now set up to transfer control to the 6502 subroutine via the execution of an **RTS** instruction which, rather than exiting the **JSR6502** routine, performs a kind of jump indirect to the value on top of the stack, the go-to address. The use of the **RTS** to transfer control to the 6502 routine is the reason the address *minus one* is put on the stack to begin with. This requirement could be eliminated if the go-to address was decremented before being pushed on the page one stack; but this would require the execution of two additional instructions, one to load it into a register, and one to decrement. **PEI** moves the value directly onto the stack from the direct page.

## The Western Design Center

When control returns from the 6502 routine, the flags, representing the 6502 routine's results, are pushed, then pulled into the eight-bit **A** accumulator after its value has been saved by transferring it to the **B** accumulator with an **XBA**. The only other item left on the new stack is the old stack pointer. This is pulled into the direct page register, which immediately restores access to all of the values pushed onto the old stack.

The condition code bits in the returned status register are merged with the mode flags in the original status register. The eight-bit result is stored in the location immediately below the return address.

The register values upon return are saved into the locations where the registers were originally pushed on the stack. Since the processor is still in emulation mode, only the low bytes are stored; the high bytes of any of the 65802/65816 registers are always preserved (which means that if a low byte is unchanged, then the entire double-byte value is preserved).

The native mode is restored. The registers are extended to sixteen bits. The stack pointer is restored from the direct page register.

There remains a gap on the stack; the value of the accumulator is copied there. The registers are now restored, with the accumulator being pulled a second time from its new location.

Control is now back with the calling 65816 program, the processor never the wiser for having been transformed into a 6502.

This coding presumes that the calling code, the switching routine, and the 6502 routine are all located in the same bank, bank zero. It also assumes a data bank of zero. Should the 6502 routine be in a non-zero bank, then you should save its program bank to a safe location prior to the switch to emulation mode so that it cannot be lost in case of interrupt. You should also check your emulation mode interrupt service routines to be sure they restore the program bank from the safe location prior to returning.

Finally, should the calling code be in a bank different from the 6502 routine, you'll have to locate the switching code in the same bank with the 6502 routine (its return will be an **RTS**); call the switching code with a **JSL**; move the pushed program bank down two bytes to the bottom of the stack before relocating the return address; and return to the calling code via an **RTL**.

## Testing Processor Type

A related utility routine (Listing 14.6) checks the processor type, allowing code targeted for the large 6502 installed-base to take advantage of a 65C02 or 65802/65816 if available. The processor is assumed to be in emulation mode if it is a 65816 or 65802.

This routine takes advantage of the fact that the 65C02 and 65816 set the sign flag correctly in the decimal mode, while the 6502 does not. The sign flag is set (minus) after loading \$99 (a negative two's-complement number). When one is added to BCD 99, the result is BCD 0, a positive two's-complement number. On the 6502, adding one decimal mode does not affect the sign flag. On the 65C02 and 65816, the sign flag is cleared to reflect that adding one results in a positive value (zero).

Having distinguished between the 65C02 and the 6502, the code further distinguishes between the 65C02 and 65816 by trying to execute one of the new 65816 instructions – specifically, the **XCE** instruction. If a 65C02 is in use, the execution of **XCE** has no effect; it simply performs a no-op, and the carry flag remains clear. On a 65816 in emulation mode, the carry flag would be set after exchanging.

0001	0000		KEEP	KL.14.6	
0002	0000		65816	ON	
0003	0000				
0004	0000		LONGA	OFF	
0005	0000		LONGI	OFF	generate '6502' code
0006	0000				
0007	0000		; CHECK	--	
0008	0000		; CHECK	PROCESSOR TYPE	
0009	0000		; MINUS	= 6502	
0010	0000		; CARRY CLEAR	= 65C02	
0011	0000		; CARRY SET	= 65816	
0012	0000				
0013	0000		CHECK	START	
0014	0000	F8	SED		Trick with decimal mode used
0015	0001	A999	LDA	#\$99	set negative flag
0016	0003	18	CLC		
0017	0004	6901	ADC	#\$01	add 1 to get new accum value of 0
0018	0006	3006	BMI	DONE	branch if 0 does not clear negative flag: 6502
0019	0008				
0020	0008				; else 65C02 or 65802 if neg flag cleared by decimal-mode arith
0021	0008				
0022	0008	18	CLC		
0023	0009	FB	XCE		OK to execute unimplemented C02 opcodes
0024	000A	9002	BCC	DONE	branch if didn't do anything:65C02
0025	000C	FB	XCE		switch back to emulation mode
0026	000D	38	SEC		set carry
0027	000E	D8	DONE	CLD	binary
0028	000F	60	RTS		
0029	0010		END		

Listing 14.6

### Compiler-Generated 65816 Code for a Recursive Program

Although it is not directly relevant to assembly-language programming per se, a look at how a compiler might generate 65816 code provides another angle on 65816 program design. You may also find it helpful when you are writing in a high-level language to have some idea as to what kind of code your compiler might be generating.

For the brief example presented here, an integer-only subset of the C programming language – such as the dialect known as “small C” – is used. To understand C, it is important to understand the concept of the **pointer**. Effectively, a pointer is a variable that holds the address of another data structure. C programmers are particularly known for their liberal use of pointers, primarily because they provide a method to manipulate data structures that is very close to the machine level. The concept of the variable itself is an abstraction which generally results in additional overhead.

The most notable thing about the use of pointers in the example is that they are limited to sixteen bits, even though the 65816 has an address space of sixteen megabytes. The sixteen-bit machine word size was chosen both for pointers and for the storage type **int**; this lets many operations be implemented using one or two 65816 instructions. As a consequence, the memory model used with this compiler limits data storage to 64K; program storage is also limited to 64K. If the loader for this hypothetical compiler supports loading of constant data and program code into separate banks, a total of 128K memory would be available to the program.

The first line of the program, shown in Listing 14.7, is the declaration of the function **main**. By convention, the function **main** is always called as the entry point to a program; it typically (but not necessarily) is the first routine coded, as it is in this example.

The curly braces define the function block; the first statement in the block is the declaration of *y*, which is a pointer variable. In C, pointers are typed by the type of the data object to which they point.

```
main ();
{
  char *y;
  y = "A string to invert";
  invert (y);
}

invert (yy) char *yy;
{
  if (*yy)
  {
    invert (yy+1);
    putchar (*yy);
  }
}
```

Listing 14.7

The first executable statement is the assignment of the string constant "A string to invert" to the variable *y*. In this context, the *y* appears without the asterisk, because the variable is being given a value – an address – rather than the string it points to. The C compiler always returns the address of a string and zero-terminates it when it encounters a string constant.

The next statement is a call to the function **invert** with a parameter of *y* (which is the variable that just received a value in the preceding statement). **Invert** is the function that actually does the work of this program, which, as you may have guessed by now, prints an inverted (backwards) string.

After the closing brace for **main** comes the declaration of the function **invert**. **Invert** takes a parameter – a pointer to a character. When **invert** is called from **main** with *y* as the parameter, *yy* assumes the value of *y*.

The code of **invert** tests the value *pointed to* by *yy*; the first time **invert** is called, this will be the letter "A", the first character in the string constant. The test is whether or not the value "at *yy*" is non-zero or not; if it is non-zero, the statements within the braces will be executed. If (or when) the value is equal to zero, the code within the braces is skipped.

Looking at the first of the pair of lines contained within the braces, you will find that it is a call to **invert** – the same function presently being defined. This calling of a routine from within itself is called *recursion*, and programming languages such as C or Pascal, which allocate their local variables on the stack, make it easy to write recursive programs such as this one. The merits of using recursion for any given problem are the subject for another discussion; however, as seen in the example, it seems quite useful for the task at hand. What happens when this function calls itself will be explored in a moment, as the generated code itself is discussed.

The last executable line of the program calls the routine **putchar**, an I/O routine that outputs the value passed it as a character on the standard (default) output device.

Returning to the top of the program, Listing 14.8 shows the code generated by the compiler to execute the C program; it is inter-listed with the source code – each line of compiler source appears as an assembler-source comment.

Before the first statement is compiled, the compiler has already generated some code: a jump to a routine labeled **CCMAIN**. **CCMAIN** is a library routine that performs the "housekeeping" necessary to provide the right environment for the generated code to run in. At the very least, **CCMAIN** must make sure the processor is in the native mode, and switch into the default (for the compiler) sixteen-bit index and accumulator word sizes. If the operating system supports it, it should also initialize the variable **argc** and **argv**, which allow the programmer access to command-line parameters, although they are not used in this example. Finally, **CCMAIN** will call **main** to begin execution of the user-writer code itself.

## The Western Design Center

0001	0000		KEEP	A.OUT
0002	0000		65816	ON
0003	0000			
0004	0000	CC0	START	
0005	0000	4C0080	JMP	CCMAIN
0006	0003		END	
0007	0000		; main ();	
0008	0000		main	START
0009	0000		{	
0010	0000		; char *y;	
0011	0000		; y = "A string to invert";	
0012	0000	DA	PHX	
0013	0001	A90080	LDA	#CCC0+0
0014	0004	8301	STA	1,S
0015	0006		; invert (y);	
0016	0006	A301	LDA	1,S
0017	0008	48	PHA	
0018	0009	200080	JSR	invert
0019	000C	FA	PLX	
0020	000D		};	
0021	000D	FA	PLX	
0022	000E	60	RTS	
0023	000F		END	
0024	0000		; invert (yy) char *yy;	
0025	0000		invert	START
0026	0000		{	
0027	0000		; if (*yy)	
0028	0000	A00000	LDY	#0
0029	0003	B303	LDA	(3,S),Y
0030	0005	29FF00	AND	#\$FF
0031	0008	D003	BNE	*+5
0032	000A	4C1F00	JMP	CC3
0033	000D		; {	
0034	000D		; invert (yy+1);	
0035	000D	A303	LDA	3,S
0036	000F	1A	INC	A
0037	0010	48	PHA	
0038	0011	200080	JSR	invert
0039	0014	FA	PLX	
0040	0015		; putchar (*yy)	
0041	0015	A00000	LDY	#0
0042	0018	B303	LDA	(3,S),Y
0043	001A	48	PHA	
0044	001B	200080	JSR	putchar
0045	001E	FA	PLX	
0046	001F		; }	
0047	001F		};	
0048	001F	60	CC3	RTS
0049	0020		END	
0050	0000			
0051	0000	CCC0	START	
0052	0000	41207374	DC	I1'\$41,\$20,\$73,\$74,\$72,\$69,\$6E,\$67'
0053	0008	20746F20	DC	I1'\$20,\$74,\$6F,\$20,\$69,\$6E,\$76,\$65'
0054	0010	727400	DC	I1'\$72,\$74,\$00'

## The Western Design Center

0055	0013		END		
0056	0000				
0057	0000	;		'LIBRARY' ROUTINES -- AS IF TO BE LINKED TO	
0058	0000	;		SOURCE PROGRAM	
0059	0000				
0060	0000	CCMAIN	START		
0061	0000	18	CLC		
0062	0001	FB	XCE		
0063	0002	C230	REP	#\$30	
0064	0004	200080	JSR	MAIN	
0065	0007	38	SEC		
0066	0008	FB	XCE		
0067	0009	60	RTS		
0068	000A		END		
0069	0000				
0070	0000				
0071	0000	PUTCHA R	START		
0072	0000	COUT	GEQU	\$FDED	Apple I I character output
0073	0000				
0074	0000				
0075	0000	A303	LDA	3,S	get parameter from stack
0076	0002				
0077	0002	08	PHP		
0078	0003	38	SEC		
0079	0004	FB	XCE		
0080	0005	20EDFD	JSR	COUT	
0081	0008	18	CLC		
0082	0009	FB	XCE		
0083	000A				
0084	000A	28	PLP		
0085	000B	60	RTS		
0086	000C		END		

**Listing 14.8**

The declaration of **main** causes an assembler **START** statement to be output; this simply defines the beginning of the subroutine or function. The declaration **char \*y** will cause the **PHX** instruction to be generated after the first line of executable code is generated; this reserves space for one variable (the pointer *y*) on the stack. That first executable code line is the assignment **y = "A string to invert"**. This causes *the address* of the string constant, which will be temporarily stored at the end of the generated program, to be loaded into the accumulator. The address just loaded into the accumulator is now stored on the stack in the memory reserved for it by the **PHX** instruction; the value of **X** that was pushed onto the stack was meaningless in itself.

The next statement to be compiled is a call to the function **invert** with the variable **y** as the parameter. This causes the value stored on the stack to be loaded back into the accumulator, where it is then pushed onto the stack. All parameters to function calls are passed on the stack.

Note that the accumulator already contained the value stored on the top of the stack; the **LDA 1,S** instruction was redundant. However, the hypothetical compiler in this example does not optimize across statements, so the potential optimization – elimination of the load instruction – cannot be realized. Once the parameter is on the top of the stack, the function itself is called via a **JSR** instruction. Since the program space is limited to 64K, only a sixteen-bit subroutine call is used. After the call returns, the **PLX** instruction removes the no-longer-needed parameter from the stack. The right bracket indicating the end of the function **main**

## The Western Design Center

causes the compiler to generate another **PLX** to remove the viable storage, an **RTS** instruction, and an assembler **END** statement.

Invert is defined as having one parameter, the character pointer *yy*. By declaring the function in this way, the compiler knows to generate code to look for the variable *yy* on top of the stack whenever a reference to it is made. You can see how this is done by looking at the code generated for the first line, which tests the value *at yy* (rather than the value *of yy*) to see whether it is *true*, that is, not equal to zero. To get this value, the stack relative indirect indexed addressing mode is used. First the **Y** register is loaded with zero, so that the first element pointed to by the indirect value on the stack is accessed. The stack offset used is three, rather than one, because when the subroutine call was made, after the parameter was pushed onto the stack, the return address was pushed onto the stack, on top of the parameter.

After the value is loaded, it must be ANDed with **\$FF** to mask out the high-order contents, since this is a character (one-byte) type of variable.

If the character is not equal to zero, as it is not the first time through, the **JMP CC3** instruction is skipped, and execution continues with the code generated for the C source statements inside the braces.

The first statement is the recursive call to **invert**. Similar to the call from **main**, a parameter is pushed onto the stack. Since an expression (*yy+1*) is being passed, however, it must first be evaluated. First the value of *yy* is loaded from the stack, and then one is added to it. Although this hypothetical compiler does not optimize across statements, it apparently does a pretty good job within them, for it has optimized the addition of one to a single increment instruction.

**Invert** is then called again. If you start counting them, you will find that more pushes than pulls will have been made at this point; in other words, the stack is growing. When **invert** is reentered, the value it finds on the stack is the starting address of the string literal *plus one*; in other words, the second element is being addressed. As long as the value pointed to by the parameter passed to **invert** is non-zero, **invert** will continue to be called recursively, and the stack will continue to grow. When the last element (with the value of zero) is reached, the recursive function “bottoms out”; the jump to **CC3** that occurs when the value at *yy* is equal to zero jumps directly to an **RTS** instruction. This causes control to return to the next statement after the call **invert**. The value of **yy** in the most recently called invocation (the value at 3,S) will be a pointer to the last character in the string; it is this character that is first loaded into the accumulator, then pushed, output via a call to the routine **putchar**, then pulled again.

Upon return from **putchar**, control falls through to the **RTS** instruction, and the next set of values on the stack are processed. This continues until all of the characters pointed to by the values on the stack have been printed, in the reverse order in which they were found. Finally, the last return executed pulls the address of the return address in **main** off the stack, and the program terminates.

### *The Same Example Hand-Coded in Assembly Language*

A distinctive characteristic of the preceding high-level language programming example was that the algorithm employed involved recursion. Consider Listing 14.9, which is the same algorithm hand-coded in assembly language; it is much more efficient than the compiler-generated example.



The Western Design Center

0001	0000			KEEP	KL.14.9	
0002	0000			65816	ON	
0003	0000					
0004	0000		MAIN	START		
0005	0000	18		CLC		
0006	0001	FB		XCE		
0007	0002					
0008	0002	C210		REP	#\$10	16-bit index registers
0009	0004			LONGI	ON	
0010	0004	E220		SEP	#\$20	8-bit accumulator
0011	0006			LONGA	OFF	
0012	0006					
0013	0006	A21900		LDX	#STRING	
0014	0009					
0015	0009	B500	INVERT	LDA	0,X	
0016	000B	F009		BEQ	DONE	
0017	000D	48		PHA		
0018	000E	E8		INX		
0019	000F	200900		JSR	INVERT	
0020	0012	68		PLA		
0021	0013	200080		JSR	COUT	
0022	0016					
0023	0016	38	DONE	SEC		
0024	0017	FB		XCE		
0025	0018	60		RTS		
0026	0019					
0027	0019	41207374	STRING	DC	C'A string to invert 'H'00'	
0028	002C			END		
0029	0000					
0030	0000					
0031	0000		;	COUT		
0032	0000		;	machine-department routine to output a character		
0033	0000		;			
0034	0000		COUT	START		
0035	0000		ECOUT	GEQU	\$FDED	Apple // COUT
0036	0000	48		PHA		Save registers
0037	0001	DA		PHX		
0038	0002	5A		PHY		
0039	0003	08		PHP		and status,
0040	0004	38		SEC		switch to emulation
0041	0005	FB		XCE		
0042	0006	20EDFD		JSR	ECOUT	call 6502 routine
0043	0009	18		CLC		
0044	000A	FB		XCE		restore native mode
0045	000B	28		PLP		restore status
0046	000C	7A		PLY		restore registers
0047	000D	FA		PLX		return
0048	000E	68		PLA		
0049	000F	60		RTS		
0050	0010			END		

Listing 14.9

## The Western Design Center

Because the more elaborate parameter-passing and variable-allocation requirements of the C language can be bypassed, the example here is much more efficient. (Although some further optimization of the compiler-generated code, as noted, is possible, the code in the example would probably be a typical result.)

To start with, a more intelligent decision about the mode flags is made right from the start, rather than coping with the default sixteen-bit accumulator size of the compiler code by making out the high-order byte whenever a character is loaded.

Secondly, full use of the index register is made, both to access the data and as the parameter-passing mechanism. Rather than push successive pointers to the inverted character string on the stack, the character itself is stored.

If this routine will be used to invert a single, known string (as opposed to making **INVERT** a subroutine for inverting *any* string, the beginning character of which is pointed to by the X register), then any assembly language programmer would simply write the code found in Listing 14.10. When the assembler evaluates the **LDX** instruction's operand, the "L:" function determines the length of **STRING**.

## The Sieve of Eratosthenes Benchmark

With all of the different factors that affect system performance, it is difficult to find a clear criterion by which to judge a processor's performance. Rightly or wrongly, the speed with which a processor runs a standard "benchmark" program is often used in forming a judgement of it. One of the most commonly used (and cited) benchmarks is the Sieve of Eratosthenes algorithm. The use of the Sieve program first gained popularity as the result of articles written by Jim Gilbreath and Gary Gilbreath, appearing in *BYTE* magazine (September 1980, page 180), and updated in January 1983 (page 283).

0001	0000			KEEP	KL.14.10	
0002	0000			65816	ON	
0003	0000					
0004	0000		MAIN	START		
0005	0000					
0006	0000	C210		REP	#\$10	16-bit index registers
0007	0002			LONGI	ON	
0008	0002	E220		SEP	#\$20	8-bit accumulator
0009	0004			LONGA	OFF	
0010	0004					
0011	0004	A21700		LDX	#L:STRING-1	get length of string less one
0012	0007					
0013	0007	BD1100	INVERT	LDA	STRING,X	get a char from end of string
0014	000A	200080		JSR	COUT	and output it
0015	000D	CA		DEX		point to previous char
0016	000E	10F7		BPL	INVERT	and loop through all characters
0017	0010	60	DONE	RTS		
0018	0011	41207374	STRING	DC	C'A string to invert 'H'00'	
0019	0024			END		
0020	0000					
0021	0000					
0022	0000			; COUT		
0023	0000			; machine-dependent routine to output a character		
0024	0000			; COUT		
0025	0000			START		
0026	0000		ECOUT	GEQU	\$FDED	Apple II COUT
0027	0000	48		PHA		Save registers
0028	0001	DA		PHX		
0029	0002	5A		PHY		
0030	0003	08		PHP		and status,
0031	0004	38		SEC		switch to emulation
0032	0005	FB		XCE		
0033	0006	20EDFD		JSR	ECOUT	call 6502 routine
0034	0009	18		CLC		
0035	000A	FB		XCE		restore native mode
0036	000B	28		PLP		restore status
0037	000C	7A		PLY		restore registers
0038	000D	FA		PLX		return
0039	000E	68		PLA		
0040	000F	60		RTS		
0041	0010			END		

Listing 14.10

The Sieve program calculates the prime numbers between 3 and 16,381; it is based on an algorithm originally attributed to the Greek mathematician Eratosthenes. The basic procedure is to eliminate every *n*th number after a given number *n*, up to the limit of range within which primes are desired. Presumably the range of primes is itself infinite.

As well as providing a common yardstick with which to gauge the 65816, the Sieve program in Listing 14.11 provides an opportunity to examine performance-oriented programming; since the name of the game is performance, any and all techniques are valid in coding an assembly-language version of a benchmark.

Four variable locations are defined for the program. **ITER** counts down the number of times the routine is executed; to time it accurately, the test is repeated 100 times. **COUNT** holds the count of primes discovered. **K** is a temporary variable. And **PRIME** is the value of the current prime number.

The variable **I** has no storage reserved for it because the **Y** register is used; it is an index counter. **Y** is used instead of **X** because certain indexed operations need the absolute,X addressing mode.

## The Western Design Center

The constant **SIZE** is equal to one-half of the range of numbers within which the primes are to be discovered; this algorithm ignores all even numbers (even numbers being non-prime). The first element in the array represents 3, the second 5, the third 7, and so on.

0001	0000			KEEP	KL.14.11	
0002	0000			65816	ON	
0003	0000					
0004	0000		ERATOS	START		
0005	0000					
0006	0000		SIZE	GEQU	8192	
0007	0000					
0008	0000		ITER	GEQU	\$80	
0009	0000		COUNT	GEQU	\$82	
0010	0000		.K	GEQU	\$84	
0011	0000		PRIME	GEQU	\$86	
0012	0000		FLAGS	GEQU	\$4000	
0013	0000					
0014	0000	18		CLC		enter native mode
0015	0001	FB		XCE		
0016	0002	C230		REP	#\$30	with 16-bit A and X
0017	0004			LONGI	ON	
0018	0004			LONGA	ON	
0019	0004					
0020	0004					
0021	0004	A96400		LDA	#100	do one hundred iterations
0022	0007	8580		STA	ITER	in order to time
0023	0009					
0024	0009	6482	AGAIN	STZ	COUNT	zero count (# of primes)
0025	000B					
0026	000B	A0FF1F		LDY	#SIZE-1	for I = 0 to size
0027	000E	A9FFFF		LDA	#\$FFFF	
0028	0011	8D0040		STA	FLAGS	(handle zero case)
0029	0014					
0030	0014	990040	LOOP	STA	FLAGS,Y	
0031	0017	88		DEY		flags[I] = TRUE
0032	0018	88		DEY		
0033	0019	10F9		BPL	LOOP	
0034	001B					
0035	001B	A00000		LDY	#0	for i = 0 to size
0036	001E		;			("i" stored in Y)
0037	001E					
0038	001E					
0039	001E	B9FF3F	MAIN	LDA	FLAGS-1,Y	if flags[I] then
0040	0021	101E		BPL	SKIP	minus-one offset: to see
0041	0023		;			high bit in long a mode
0042	0023	98		TYA		
0043	0024	0A		ASL	A	prime = I + I + 3
0044	0025	1A		INC	A	
0045	0026	1A		INC	A	
0046	0027	1A		INC	A	
0047	0028	8586		STA	PRIME	
0048	002A					
0049	002A	98		TYA		
0050	002B	18		CLC		
0051	002C	6586		ADC	PRIME	k = i + prime
0052	002E					
0053	002E	C90120	TOP	CMP	#SIZE+1	while k <= size
0054	0031	B00C		BGE	SKIP2	
0055	0033					

## The Western Design Center

0056	0033	AA		TAX		flags[k] = FALSE
0057	0034					
0058	0034	E220		SEP	#\$20	clear only
0059	0036	9E0040		STZ	FLAGS,X	one byte
0060	0039	C221		REP	#\$21	clears carry as well
0061	003B					
0062	003B	6586		ADC	PRIME	k = k + prime
0063	003D	80EF		BRA	TOP	(end while k <= size)
0064	003F					
0065	003F	E682	SKIP2	INC	COUNT	
0066	0041					
0067	0041	C8	SKIP	INY		(end for i = 0 to size)
0068	0042	C00120		CPY	#\$SIZE+1	
0069	0045	D0D7		BNE	MAIN	
0070	0047					
0071	0047	C680		DEC	ITER	
0072	0049	D0BE		BNE	AGAIN	
0073	004B					
0074	004B	38		SEC		
0075	004C	FB		XCE		
0076	004D	60		RTS		
0077	004E					
0078	004E					
0079	004E			END		

Listing 14.11

The program begins by entering the native mode and extending the user registers to sixteen bits. **ITER** is initialized for 100 iterations. An array (starting at **FLAGS**) of memory of size **SIZE** is initialized to \$FF's, two bytes at a time.

The routine proper now begins. **Y** is initialized with zero, and control falls into the main loop. The high-order bit of each cell of the array **FLAGS** is tested. Initially, they are all set, but the algorithm iteratively clears succeeding non-prime values before they are tested by this code. If the high bit is clear, this number has already been eliminated by the algorithm; it is non-prime. Notice that the high-order bit of the **FLAG[I]** (or **FLAG[Y]**) array is desired; however, since the processor is in sixteen-bit mode, the high bit will be loaded from the memory location at the effective address *plus one*. To overcome this, the base of the array is specified as the actual base minus one; this calculation is performed by the assembler during generation of the object code.

If the current value has not been cleared, the algorithm calls for the number which is two times the current index value plus three (this converts the index to the array values of 3, 5, 7 . . . ) to be the next value for **PRIME**. This prime number is generated quickly by transferring the **Y** index register into the accumulator, shifting it left once to multiply by two, and incrementing it three times. Remember, this number is generated from the current index only if the index value has not already been eliminated as being non-prime.

This prime number is then added to the current index, and the array elements at this offset, and at all succeeding indices every **PRIME** value apart are eliminated from the array as being non-prime. They have the current prime number as one of their factors. The most significant thing to note here in the code is that only one byte can be cleared; the accumulator must temporarily be switched into the eight-bit mode to accomplish this. However, since the next operation is an addition, an optimization is available: both the sixteen-bit mode can be restored and the carry cleared in a single **REP** operation.

The program now loops, checking to see if the next index value has been eliminated; this process continues until the index reaches the limit of **SIZE**.

You may be wondering what the result is: at 4 MHz, ten iterations are completed in 1.56 seconds, which is twice as fast as a 4MHz 6502. The January, 1983 *BYTE* article cites results of 4.0 seconds for a 5MHz 8088, 1.90 seconds for an 8 MHz 8086, and .49 seconds for an 8 MHz 68000; an 8 MHz 65816 would yield .78 seconds.

# 15) Chapter Fifteen

## DEGUG16 – A 65816 Programming Tool

This chapter consists of a complete 65816 application example and a detailed discussion of its dozen or so routines. Where possible, different programming techniques have been employed in an effort to illustrate some of the different methods of coding that are available.

The program, **DEBUG16**, is a rudimentary step-and-trace debugger. A **debugger** is a tool used during software development to isolate and reveal sources of error in the program being tested. In other words, it helps the programmer eliminate the **bugs** in a program, hence the name. A **step-and-trace** function lets the program be halted after the execution of each single instruction and the registers and possibly other memory locations to be examined. This effectively provides a “view” into the otherwise invisible internals of the processor.

The ability to trace programs in this manner can be extremely useful: uninitialized variables, wild branches, infinite loops – all of the common flaws that normally result in your program going away to never-never land with little clue to their reasons for departure – are made visible. In addition to display the register contents, a tracer will also list the opcode mnemonic and display the operand using the same syntax as originally specified in the source program. This process is called **disassembly**. Although the tracing program can accurately regenerate an approximation of the source line that resulted in a given instruction, it cannot determine any of the symbolic labels that might have been given to the address found by the tracer in the assembler source program. More sophisticated debuggers called *symbolic debuggers* let you load a program’s symbol table created by either the link editor or assembler; the debugger’s disassembly routine looks up each address in a disassembly in the symbol table and insert labels in place of addresses wherever a correspondence is found.

**DEBUG16** also has a **LIST** entry point, at which its disassembler can be used apart from its tracer; this lets you re-create a listing of a program without having the source code available. Again, there is no symbolic information (labels) available. Additionally, the disassembler in its current form does not deal with variable lengths of immediate operands when in the **LIST** mode.

The tracer can display the disassembled instruction and register values either one instruction at a time, or allow the trace to execute in free-running mode. When only one instruction is disassembled at a time, the tracer is said to be **single-stepping**; pressing a key lets the next instruction be executed. Pressing **RETURN** toggles the tracer into free-running mode. While free-running, a single key press will pause the trace. Pressing any key except **RETURN** resumes tracing ; **RETURN** switches back to single-stepping.

The basic theory of operation of the tracer is simple. Starting with the first program instruction, the tracer calculates the length of the instruction by first determining the addressing mode associated with the opcode, and then referring to a table that gives the instruction lengths for the different addressing modes. It can therefore determine the location of the next instruction that follows the current one. It places a **BRK** instruction at that location, having first saved the original value stored there. Next, it executes (via a **JMP** instruction) the current instruction. As soon as that instruction completes, the program counter increments to the next instruction, where it encounters the insert **BRK**. **BRK** initiates an interrupt cycle that returns control back to the tracer, saves copies of all of the processor’s register contents to memory, then calls a routine which displays them, along with the disassembled instruction.

When the next step (next instruction) is to be executed, the **BRK** instruction is replaced with its original value, and the cycle is repeated. In this way the program is able to gain control of the processor “in between” the execution of each instruction.

The exception to this method is whenever an instruction (such as a branch or jump) is encountered which can change the flow of control; in these cases, the target location must be determined (by examining the operand of the instruction), and a **BRK** inserted at that location instead.

The disassembly output looks like Figure 15.1.

## The Western Design Center

```
00:2000  4CCB22  JMP    $22CB
00:2003   08      PHP
00:2004   18      CLC
00:2005   FB      XCE
00:2006   08      PHP
00:2007   08      PHD
00:2008  F40003  PEA    $0300
00:200B   2B      PLD
00:200C  C220     REP    #$20
00:200E  E210     SEP    #$10
```

Figure 15-1 Disassembly Output

And the tracer output looks like Figure 15.2.

```
00:5000  A905  LDA    #$05
A= 15 05 X= 00 11 Y= 00 13 S= 01 AA D= 00 00 B= 00 P= 7D E:1
00:5002  AB    TAY
A= 15 05 X= 00 11 Y= 00 05 S= 01 AA D= 00 00 B= 00 P= 7D E: 1
00:5003  90060 STA    $600,Y
A= 15 05 X= 00 11 Y= 00 05 S= 01 AA D= 00 00 B= 00 P= 7D E: 1
00:5006  88    DEY
A= 15 05 X= 00 11 Y= 00 04 S= 01 AA D= 00 00 B= 00 P=7D E:1
00:5007  D0FA  BNE    $5003
A= 15 05 X= 00 11 Y= 00 04 S= 01 AA D= 00 00 B= 00 P= 7D E:1
00:5003  990060 STA    $600,Y
A= 15 05 X= 00 11 Y= 00 04 S= 01 AA D= 00 00 B= 00 P= 7D E:1
00:5006  88    DEY    $5003
A= 15 05 X= 00 11 Y= 00 03 S= 01 AA D= 00 00 B= 00 P= 7D E:1
00:5007  D0FA  BNE    $6000,Y
A= 15 05 X= 00 11 Y= 00 03 S= 01 AA D= 00 00 B= 00 P= 7D E:1
00:5003  990060 STA
A= 15 05 X= 00 11 Y= 00 03 S= 01 AA D= 00 00 B= 00 P= 7D E:1
00:5006  88    DEY
A= 15 05 X= 00 11 Y= 00 02 S= 01 AA D= 00 00 B= 00 P= 7D E: 1
```

Figure 15-2 Tracer Output

This example was developed and tested using an AppleIIe with a 65816 processor card installed; the calls to machine-dependent locations have been isolated and are clearly as such. **DEBUG16** uses the native **BRK** vector. On the AppleII, this location (\$FFE6, FFE7) normally contains ROM data, which varies between monitor ROM versions. Since there is no way to patch ROM, the solution opted for here is for **DEBUG16** to try to patch the location pointed to by the data that is stored there. For current ROMs, these are RAM locations that happen to be more or less livable. Check the location pointed to by your ROMs, and make sure that neither your own code nor the debugger are loaded into that area. **DEBUG16** will automatically read whatever value is stored there and store a vector to that address to regain control after a **BRK**.

Both programs are executed by putting the starting address of the routine to list or trace (which has been loaded into memory) at **DPAGE+80.82** (\$380.82) in low – high – bank order, and then calling either the **TRACE** entry point at \$2000, or the **LIST** entry at \$2003.

**Declarations**

The listing begins with the declaration of global values by way of **GEQU** statements. Almost all of these are addresses of direct page memory locations that will be used; one notable exception is the label **DPAGE**, a sixteen-bit value that defines the beginning of the direct page memory to be used by this program. Because a 65816 debugger is by definition a 6502 debugger, it is wise to relocate the direct page out of the default zero page, since it will be used by 65802 programs, and your program being debugged. In the listing, a value of \$300 is used; on an Apple II, this relocates the direct page to page three, which is a convenient page to use.

Many of the direct page locations are used to store the register contents of the user program when the debugger is executing. All of the registers are represented. As you will see in the code, the adjacent positioning of some of the registers is important and must be maintained.

In addition to the direct page location used for register storage, one general-purpose temporary variable is used, called **TEMP**. Three other variables – **ADDRMODE**, **MNX**, and **OPLN** (for *address mode*, *mnemonic index*, and *operation length*, respectively) – are used primarily to access the tables used in disassembling an instruction.

The variable **CODE** contains the instruction opcode currently being executed in the user program. The variable **NCODE** contains the *next* instruction opcode to be executed, saved there before being replaced with the **BRK** instruction inserted in the code. **OPRNDL**, **OPRNDH**, and **OPRNCB** contain the three (possible) values of the operand of a given instruction.

```

0001 0000
0002 0000          KEEP    DEBUG16
0003 0000
0004 0000          65816   ON
0005 0000          MSB     ON
0006 0000          LONGA   OFF
0007 0000          LONGI   OFF
0008 0000
0009 0000          *****
0010 0000          *
0011 0000          *   DEBUG16
0012 0000          *   A 65816 DEBUGGER
0013 0000          *
0014 0000          *
0015 0000          *****
0016 0000
0017 0000          ORG     $8000
0018 0000
0019 0000          MAIN    START
0020 0000
0021 0000          USING   MN
0022 0000          USING   ATRIBL
0023 0000
0024 0000
0025 0000          DPAGE   GEQU    $300          LOCATION OF THIS APPLICATION'S
0026 0000          ;
0027 0000
0028 0000          ;          DIRECT PAGE STORAGE
0029 0000          ;          TRACE REGISTERS
0030 0000          ;
0031 0000
0032 0000          PCREG   GEQU    $80          PROGRAM COUNTER
0033 0000          PCREGH  GEQU    PCREG+1
0034 0000          PCREGB  GEQU    PCREGH+1      INCLUDING BANK
0035 0000
0036 0000          NCODE   GEQU    PCREGB+1     NEXT CODE TO BE TRACED
0037 0000
0038 0000          OPCREG  GEQU    NCODE+1      OLD PROGRAM COUNTER VALUE
0039 0000          OPCREGH  GEQU    OPCREG+1
0040 0000          OPCREGB  GEQU    OPCREGH+1

```



## The Western Design Center

0041	0000				
0042	0000	CODE	GEQU	OPCREGB+1	CURRENT CODE TO BE TRACED
0043	0000				
0044	0000	OPRNDL	GEQU	CODE+1	OPERANDS OF CURRENT
0045	0000	OPRNDH	GEQU	OPRNDL+1	INSTRUCTION
0046	0000	OPRNDB	GEQU	OPRNDH+1	
0047	0000				
0048	0000				
0049	0000	XREG	GEQU	OPRNDB+1	X REGISTER
0050	0000	XREGH	GEQU	XREG+1	
0051	0000				
0052	0000	YREG	GEQU	XREGH+1	Y REGISTER
0053	0000	YREGH	GEQU	YREG+1	
0054	0000				
0055	0000	AREG	GEQU	YREGH+1	ACCUMULATOR
0056	0000	AREGH	GEQU	AREG+1	
0057	0000				
0058	0000	STACK	GEQU	AREGH+1	STACK POINTER
0059	0000	STACKH	GEQU	STACK+1	
0060	0000				
0061	0000				
0062	0000	DIRREG	GEQU	STACKH+1	DIRECT PAGE REGISTER
0063	0000	DIRREGH	GEQU	DIRREG+1	
0064	0000				
0065	0000	DBREG	GEQU	DIRREGH+1	DATA BANK REGISTER
0066	0000				
0067	0000	PREG	GEQU	DBREG+1	P STATUS REGISTER
0068	0000				
0069	0000	EBIT	GEQU	PREG+1	E BIT
0070	0000				
0071	0000	TEMP	GEQU	EBIT+2	TEMPORARY
0072	0000	TEMPH	GEQU	TEMP+1	
0073	0000	TEMPB	GEQU	TEMPH+1	
0074	0000				
0075	0000				
0076	0000	ADDRMODE	GEQU	TEMPB+1	ADDRESS MODE OF CURRENT OPCODE
0077	0000				
0078	0000	MNX	GEQU	ADDRMODE+1	MNEMONIC INDEX
0079	0000	;			FROM ATTRIBUTE TABLE
0080	0000				
0081	0000	OPLN	GEQU	MNX+2	LENGTH OF OPERATION,
0082	0000	;			INCLUDING INSTRUCTION
0083	0000				
0084	0000	CR	GEQU	\$8D	CARRIAGE RETURN
0085	0000				
0086	0000				
0087	0000	M	GEQU	\$20	SYBOLIC NAMES FOR
0088	0000	X	GEQU	\$10	STATUS REGISTER BITS
0089	0000	C	GEQU	\$01	
0090	0000				
0091	0000				
0092	0000				
0093	0000	4C008 0	JMP	TRACE	

## LIST

The program has two entry points, defined in the first routine. One is for listing (disassembling) a program, the other for tracing. The first entry point, at the program's origin (default \$8000), is jump to the actual entry point of the trace routine; the second, immediately past it (at \$8003), is the beginning of the code for the disassembler.

Since this is a bare-bone disassembler, intended to be expanded and perhaps integrated with a general purpose machine language monitor, parameters such as the start address of the program to be traced are entered by modifying the values of the register variables; for example, to begin disassembly of a program stored at \$800, the values \$00 \$08, and \$00 are stored starting at **PCREG**. Since the direct page is relocated to page three, the absolute location of this variable is \$380.

Starting at the **LIST** entry, some basic initialization is performed: saving the status register, switching to native mode, and then saving the previous operating mode (emulation/native) by pushing the status register a second time (the carry flag now containing the previous contents of the e bit). Thus this program may be called from either native or emulation mode.

The current value of the direct page is saved in program memory, and then the new value – **DPAGE** – is stored to the direct page register. The native mode is entered.

Control now continues at **TOP**, the beginning of the main loop of the disassembler. The mode is set to long accumulator, short index. This combination allows simple manipulation of both byte and double-byte values. The value of **PCREG** is copied to **OPCREG** (old pcreg). **OPCREG** will contain the starting location of the current instruction throughout the loop; **PCREG** will be modified to point to the next instruction. However, it hasn't been modified yet, so it is used to load the accumulator with the opcode byte. Indirect long addressing is used, so code anywhere within the sixteen-megabyte address space may be disassembled. Since the accumulator is sixteen bits, a second byte is fetched as well, but ignored; the next instruction transfers the opcode to the **X** register and then stores it at the location **CODE**.

The utility routine **UPDATE** is called next. This is common to both the disassembler and the tracer, and determines the attributes of this instruction by looking the instruction up in a table; it also increments the program counter to point to the next instruction.

The routines **FLIST**, **FRMOPRND**, and **PRINTLN** form the disassembled line and display it. After each line is printed, the routine **PAUSE** is called to check the keyboard to see if a key has been pressed, signalling a pause. If **PAUSE** returns with the carry clear, it means the user has signalled to quit, and control falls through to **QUIT**; otherwise, the program loops to **TOP** again, where it repeats the process for the next instruction.

# The Western Design Center

0094	0003				
0095	0003				
0096	0003				
0097	0003		LIST		
0098	0003		MAIN LOOP OF DISASSEMBLER FUNCTION		
0099	0003				
0100	0003				
0101	0003				
0102	0003				
0103	0003				
0104	0003	LIST	ENTRY		
0105	0003	08	PHP		SAVE ORIGINAL FLAGS
0106	0004	18	CLC		
0107	0005	FB	XCE		SET NATIVE MODE
0108	0006	08	PHP		SAVE PREVIOUS MODE
0109	0007				
0110	0007	0B	PHD		SAVE CURRENT DP
0111	0008	F40003	PEA	DPAGE	
0112	000B	2B	PLD		SET TO NEW DP
0113	000C				
0114	000C		TOP	ANOP	
0115	000C				
0116	000C	C220	REP	#M	
0117	000E	E210	SEP	#X	
0118	0010		LONGA	ON	
0119	0010		LONGI	OFF	
0120	0010				
0121	0010	649D	STZ	MNX	CLEAR MNEMONIC INDEX
0122	0012	A580	LDA	PCREG	MOVE PROGRAM COUNTER
0123	0014	8584	STA	OPCREG	TO 'OLD PROGRAM COUNTER'
0124	0016	A682	LDX	PCREGB	INCLUDING BANK
0125	0018	8686	STX	OPCREGB	
0126	001A	A780	LDA	[PCREG]	GET NEXT INSTRUCTION
0127	001C	AA	TAX		
0128	001D	8687	STX	CODE	SAVE AS 'CODE'
0129	001F				
0130	001F	200080	JSR	UPDATE	UPDATE ATTRIBUTE VARIABLES
0131	0022				
0132	0022	200080	JSR	FLIST	FORM OBJECT CODE, MNEMONIC
0133	0025	200080	JSR	FRMOPRNND	FORM OPERAND FIELD
0134	0028	200080	JSR	PAUSE	CHECK FOR USER PAUSE
0135	002B	9005	BCC	QUIT	
0136	002D	200080	JSR	PRINTLN	PRINT IT
0137	0030				
0138	0030	80DA	BRA	TOP	LOOP TIL END
0139	0032				
0140	0032	2B	QUIT	PLD	RESTORE ENVIRONMET,
0141	0033	28		PLP	RETURN TO CALLER
0142	0034	FB		XCE	
0143	0035	28		PLP	
0144	0036	60		RTS	
0145	0037			END	
0146	0037				
Local Symbols					
LIST	00003	QUIT	000032	TOP	0000C

## FLIST

**FLIST** is called by both the disassembler and the tracer. This routine displays the current program counter value, the object code of the instruction being disassembled in hexadecimal, and the mnemonic for the opcode. The code required to do this is basically the same for any instruction, the only difference being the length of the instruction, which has already been determined by **UPDATE**.

The first thing the code does is to blank the output buffer by calling **CLRLN**. Particularly since 6502 emulation-mode I/O routines are used, it is more efficient to build an output line first, then display it all at once, rather than output the line “on the fly.” Characters are stored in the output buffer **LINE** via indexed absolute addressing; the **Y** register contains a pointer to the current character position within the line, and is incremented every time a character is stored. Since character manipulation is the primary activity in this routine, the accumulator is set to eight bits for most of the routine.

The flow of the program proceeds to generate the line from left to right, as it is printed; the first characters stored are therefore the current program counter values. Since **UPDATE** has already modified the program counter variable to load the operands of the instruction, the value in the variable **OPCREG** is used. The hex conversion routine, **PUTHEX**, converts the data in the accumulator into the ASCII characters that represents the number’s two hexadecimal digits, storing each character at the location pointed to by **LINE, Y**, and then incrementing **Y** to point to the next character. A colon is printed between the bank byte and the sixteen-bit program counter display to aid readability.

Next, some spaces are skipped by loading the **Y** register with a higher value, and the object code bytes are displayed in hexadecimal. These values have already been stored in direct page memory locations **CODE** and **OPRNDL**, **OPRNDH**, and **OPNDB** by the **UPDATE** routine, which also determined the length of the instruction and stored it at **OPLEN**. The length of the operand controls a loop that outputs the bytes; note that a negative displacement of one is calculated by the assembler so that the loop is not executed when **OPLEN** is equal to one.

All that remains is to print the instruction mnemonic. The characters for all of the mnemonics are stored in a table called **MN**; at three characters per mnemonic (which as you may have noticed is the standard length for all 65x mnemonics), the mnemonic index (**MNX**) determined by **UPDATE** from the instruction attribute table must be multiplied by three. This is done by shifting left once (to multiply by two), and adding the result to the original value of **MNX**. Note that this type of “custom” multiplication routine is much more efficient than the generalized multiplication routines described in the previous chapter. The characters in the mnemonic table are copied into the output line using the **MVN** instruction; the result just calculated is transferred into the **X** register as the source of the move. It is the line-buffered output that allows use of the block-move instruction; on-the-fly output would have required each character to be copied out of the mnemonic table in a loop.

# The Western Design Center

0147			:		
0148			:	FLIST – FORM IMAGE OF PROGRAM COUNTER,	
0149			:	OBJECT CODE, AND MNEMONIC IN ‘LINE’	
0150			:		
0151			:	REQUIRES ATTRIBUTE VARIABLES TO BE PREVIOUSLY INITIALIZED	
0152			:	.....	
0153			:		
0154			:		
0155			FLIST	START	
0156				USING	MN
0157					
0158		200080		JSR	CLRLN      BLANK ‘LINE’ VARIABLE
0159	0003				
0160	0003	E230		SEP	#M+X      SHORT REGISTERS
0161	0005			LONGA	OFF
0162	0005			LONGI	OFF
0163	0005				
0164	0005	A000		LDY	#0
0165	0007	A586		LDA	OPCREGB      GET BANK BYTE, FORM AS HEX
0166	0009	200080		JSR	PUTHEX      STRING
0167	000C	A9BA		LDA	#’:’      BANK DELIMITER
0168	000E	990080		STA	LINE,Y
0169	0011	C8		INY	
0170	0012	A585		LDA	OPCREGH      GET BYTES OF PROGRAM COUNTER
0171	0014	200080		JSR	PUTHEX      FORM AS HEX STRING IN
0172	0017	A584		LDA	OPCREG      LINE
0173	0019	200080		JSR	PUTHEX
0174	001C				
0175	001C	A00A		LDY	#10
0176	001E	A587		LDA	CODE      STORE OPCODE AS HEX STRING
0177	0020	20080		JSR	PUTHEX
0178	0023	A201		LDX	#1
0179	0025				
0180	0025	E49F	MORE	CPX	OPLN      LIST OPERANDS, IF ANY
0181	0027	F008		BEQ	DONE
0182	0029	B587		LDA	OPRNDL-1,X
0183	002B	200080		JSR	PUTHEX
0184	002E	E8		INX	
0185	002F	80F4		BRA	MORE
0186	0031				
0187	0031	C23	DONE	REP	#M+X
0188	0033			LONGA	ON
0189	0033			LONGI	ON
0190	0033				
0191	0033	A59D		LDA	MNX      GET MNEMONIC INDEX,
0192	0035	0A		ASL	A      MULTIPLY BY THREE
0193	0036	18		CLC	(TIMES TWO PLUS SELF)
0194	0037	659D		ADC	MNX
0195	0039	18		CLC	
0196	003A	690080		ADC	#MN
0197	003D	AA		TAX	
0198	003E	A01480		LDY	#LINE+20      INDEX INTO MNEMONIC TABLE
0199	0041	A90200		LDA	#2      COPY INTO ‘LINE’
0200	0044		MOVE	ENTRY	
0201	0044	540000		MVN	0,0
0202	0047				
0203	0047	60		RTS	
0204	0048			END	
Local Symbols					
DONE	000031	MORE	000025	MOVE	000044

## FRMOPRND

This is the second part of the line-disassembly pair. It performs the address-mode specific generation of the disassembled operand field; the result is similar to the address mode specification syntax of a line of 65x source code.

The Y register is loaded with the starting destination in **LINE**, and the attribute stored at **ADDRMODE** is multiplied by two to form an index into a jump table. There is a separate routine for each addressing mode; the address of that routine is stored in a table called **MODES** in the order that corresponds to the attributes given them from the attribute table.

The **JMP** indirect indexed instruction is used to transfer control through the jump table **MODES** to the appropriate routine, whose index, times two, has been loaded into the **X** register.

Each of the routines is basically similar; they output any special characters and print the address of the operand found in the instruction stream. There are three relative routines, **POB**, **PODB**, and **POTB** (for put operand byte, put operand double byte, and put operand triple byte) which output direct page, absolute, and absolute long addresses.

The two routines **FPCR** and **FPCRL**, which handle the program counter relative instructions, however, must first calculate the destination address (which is how an assembler would specify the operand, so this is how they are disassembled) by adding the actual operand, a displacement, to the current program counter. The operand of a short program counter relative instruction is sign-extended before adding, resulting in a sixteen-bit signed displacement which is added to the program counter to find the destination address.

# The Western Design Center

0205	0000				
0206	0000				
0207	0000				
0208	0000			FRMOPRND --	
0209	0000			FORMS OPERAND FIELD OF DISASSEMBLED INSTRUCTION	
0210	0000				
0211	0000			OPLN, ADDRMODE, AND OPRND MUST HAVE BEEN	
0212	0000			INITIALIZED BY 'UPDATE'	
0213	0000				
0214	0000				
0215	0000				
0216	0000		FRMOPRND	START	
0217	0000			USING	MODES
0218	0000	E230		SEP	#M+X
0219	0002			LONGA	OFF
0220	0002			LONGI	OFF
0221	0002				
0222	0002	A01C		LDY	#28
0223	0004				OFF SET INTO 'LINE' FOR OPERAND TO BEGIN
0224	0004	A59C		LDA	ADDRMOD
0225	0006	0A			E
0226	0007	AA		ASL	A
0227	0008	7C0080		TAX	TWO, JUMP THROUGHT ADDRESS MODE JUMP TABLE TO PROPER HANDLER
0228	000B			JMP	(MODES,X)
0229	000B				
0230	000B		FIMM	ENTRY	IMMEDIATE MODE --
0231	000B	A9A3		LDA	##'
0232	000D	990080		STA	LINE,Y
0233	0010	C8		INY	ONE OR TWO OPERAND BYTES, DEPENDING ON OPLEN
0234	0011	A59F		LDA	OPLEN
0235	0013	C902		CMP	#2
0236	0015	F003		BEQ	GOSHORT
0237	0017	4C0080		JMP	PODB
0238	001A	4C0080	GOSHORT	JMP	POB
0239	001D				
0240	001D		FABS	ENTRY	ABSOLUTE MODE --
0241	001D	4C0080		JMP	PODB
0242	0020				JUST OUTPUT A DOUBLE BYTE
0243	0020		FABSL	ENTRY	ABSOLUTEW LONG --
0244	0020	4C0080		JMP	POTB
0245	0023				OUTPUT A TRIPLE BYTE
0246	0023		FDIR	ENTRY	DIRECT MODE --
0247	0023	4C0080		JMP	POB
0248	0026				OUTPUT A SINGLE BYTE
0249	0026		FACC	ENTRY	ACCUMULATOR --
0250	0026	A9C1		LDA	#'A'
0251	0028	990080		STA	LINE,Y
0252	002B	60		RTS	JUST AN A
0253	002C				
0254	002C		FIMP	ENTRY	IMPLIED --
0255	002C	60		RTS	NO OPERAND
0256	002D				
0257	002D		FINDINX	ENTRY	INDIRECT INDEXED --
0258	002D	20B600		JSR	FIND
0259	0030				CALL 'INDIRECT', THEN FALL THROUGH TO INDEXED BY Y
0260	0030				
0261	0030		FINY	ENRTRY	INDEXED BY Y MODES --
0262	0030	A9AC		LDA	#','
0263	0032	990080		STA	LINE,Y
0264	0035	C8		INY	TACK ON A 'COMMA,Y'
0265	0038	A9D9		LDA	#'Y'
0266	003B	990080		STA	LINE,Y

## The Western Design Center

0267	003B	60		RTS		
0268	003C					
0269	003C		FINDINXL	ENTRY		INDIRECT INDEXED LONG --
0270	003C	20C600		JSR	FINDL	CALL 'INDIRECT LONG', THEN
0271	003F	4C3000		JMP	FINY	EXIT THROUGH INDEXED BY Y
0272	0042					
0273	0042		FINXIND	ENTRY		INDEX INDIRECT --
0274	0042	A9A8		LDA	#('	PARENTHESIS
0275	0044	990080		STA	LINE,Y	
0276	0047	C8		INY		
0277	0048	200080		JSR	POB	A SINGLE BYTE --
0278	004B	206000		JSR	FINX	COMMA, X
0279	004E	A9A9		LDA	#)'	CLOSE.
0280	0050	990080		STA	LINE,Y	
0281	0053	60		RTS		
0282	0054					
0283	0054		FDIRINXX	ENTRY		DIRECT INDEXED BY X --
0284	0054	200080		JSR	POB	OUTPUT A BYTE,
0285	0057	4C6000		JMP	FINX	TACK ON COMMA, X
0286	005A					
0287	005A		FDIRINXY	ENTRY		DIRECT INDEXED BY Y --
0288	005A	200080		JSR	POB	OUTPUT A BYTE,
0289	005D	4C3000		JMP	FINY	TACK ON COMMA, Y
0290	0060					
0291	0060		FINX	ENTRY		INDEXED BY X --
0292	0060	A9AC		LDA	#,'	TACK ON A
0293	0062	990080		STA	LINE,Y	COMMA, X
0294	0065	C8		INY		(USED BY SEVERAL
0295	0066	A9D8		LDA	#'X'	MODES)
0296	0068	990080		STA	LINE,Y	
0297	006B	C8		INY		
0298	006C	60		RTS		
0299	006D					
0300	006D		FABSX	ENTRY		ABSOLUTE INDEXED BY X --
0301	006D	200080		JSR	PODB	OUTPUT A DOUBLE BYTE,
0302	0070	4C6000		JMP	FINX	TACK ON A COMMA, X
0303	0073					
0304	0073		FABSLX	ENTRY		ABSOLUTE LONG BY X --
0305	0073	200080		JSR	POTB	OUTPUT A TRIPLE BYTE,
0306	0076	4C6000		JMP	FINX	TACK ON COMMA, X
0307	0079					
0308	0079		FABSY	ENTRY		ABSOLUTE Y --
0309	0079	200080		JSR	PODB	OUTPUT A DOUBLE BYTE,
0310	007C	4C3000		JMP	FINY	TACK ON COMMA,Y
0311	007F					
0312	007F		FPCR	ENTRY		PROGRAM COUNTER RELATIVE --
0313	007F	A9FF		LDA	#\$FF	SIGN EXTEND OPERAND
0314	0081	EB		XBA		
0315	0082	A588		LDA	OPRNDL	
0316	0084	C221		REP	#M+C	
0317	0086			LONGA	ON	
0318	0086	3003		BMI	OK	
0319	0088	297F00		AND	#\$7F	
0320	008B	6584	OK	ADC	OPCREG	ADD TO PROGRAM COUNTER
0321	008D	1A		INC	A	ADD TWO, WITHOUT CARRY
0322	008E	1A		INC	A	
0323	008F	8588		STA	OPRNDL	STORE AS NEW 'OPERAND'
0324	0091					
0325	0091	E220		SEP	#M	
0326	0093			LONGA	OFF	
0327	0093					
0328	0093	4C0080		JMP	PODB	NOW JUST DISPLAY A DOUBLE BYTE
0329	0096					
0330	0096		FCPRL	ENTRY		PROGRAM COUNTER RELATIVE LONG
0331	0096					



## The Western Design Center

0332	0096	C221	REP	#M+C	
0333	0098		LONGA	ON	
0334	0098				
0335	0098	A588	LDA	OPRNDL	JUST ADD THE OPERAND
0336	009A	6584	ADC	OPCREG	
0337	009C	18	CLC		BUMP BY THREE, PAST INSTRUCTION
0338	009D	690300	ADC	#3	
0339	00A0	8588	STA	OPRNDL	STORE AS NEW 'OPERAND'
0340	00A2				
0341	00A2	E220	SEP	#M	
0342	00A4		LONGA	OFF	
0343	00A4				
0344	00A4	4C0080	JMP	PODB	PRINT A DOUBLE BYTE
0345	00A7				
0346	00A7		FABSIND	ENTRY	ABSOLUTE INDIRECT
0347	00A7	A9A8	LDA	#('	SURROUND A DOUBLE BYTE
0348	00A9	990080	STA	LINE,Y	WITH PARENTHESES
0349	00AC	C8	INY		
0350	00AD	200080	JSR	PODB	
0351	00B0	A9A9	LDA	#)'	
0352	00B2	990080	STA	LINE,Y	
0353	00B5	60	RTS		
0354	00B6				
0355	00B6		FIND	ENTRY	INDIRECT --
0356	00B6	A9A8	LDA	#('	SURROUND A SINGLE BYTE
0357	00B8	990080	STA	LINE,Y	WITH PARENTHESES
0358	00BB	C8	INY		
0359	00BC	200080	JSR	POB	
0360	00BF	A9A9	LDA	#)'	
0361	00C1	990080	STA	LINE,Y	
0362	00C4	C8	INY		
0363	00C5	60	RTS		
0364	00C6				
0365	00C6		FINDL	ENTRY	INDIRECT LONG --
0366	00C6	A9DB	LDA	#['	SURROUND A SINGLE BYTE
0367	00C8	990080	STA	LINE,Y	WITH SQUARE BRACKTS
0368	00CB	C8	INY		
0369	00CC	200080	JSR	POB	
0370	00CF	A9DD	LDA	# ]'	
0371	00D1	990080	STA	LINE,Y	
0372	00D4	C8	INY		
0373	00D5	60	RTS		
0374	00D6				
0375	00D6		FABSINXIN D	ENTRY	ABSOLUTE INDIRECT INDEXED
0376	00D6	A9A8	LDA	#('	
0377	00D8	990080	ST5A	LINE,Y	SURROUND A CALL TO 'ABSOLUTE
0378	00DB	C8	INY		INDEXED' WITH PARENTHESES
0379	00DC	206D00	JSR	FABSX	
0380	00DF	A9A9	LDA	#)'	
0381	00E1	990080	STA	LINE,Y	
0382	00E4	60	RTS		
0383	00E5				
0384	00E5		FSTACK	ENTRY	STACK -- IMPLIED
0385	00E5	60	RTS		
0386	00E6				
0387	00E6		FSTACKREL	ENTRY	STACK RELATIVE
0388	00E6	202300	JSR		JUST LIKE
0389	00E9	A9AC	LDA		DIRECT INDEXED, BUT WITH
0390	00EB	990080	STA		AN 'S'
0391	00EE	C8	INY		
0392	00EF	A9D3	LDA	#'S''	
0393	00F1	990080	STA	LINE,Y	
0394	00F4	C8	INY		
0395	00F5	60	RTS		

## The Western Design Center

0396	00F6					
0397	00F6					
0398	00F6		FSRINDINX	ENTRY		STACK RELATIVE INDIRECT INDEX
0399	00F6	A9A8		LDA	#'('	
0400	00F8	990080		STA	LINE,Y	SURROUND STACK RELATIVE WITH
0401	00FB	C8		INY		PARENTHESES, THEN
0402	00FC	20E600		JSR	FSTACKREL	
0403	00FF	A9A9		LDA	#')'	
0404	0101	990080		STA	LINE,Y	
0405	0104	C8		INY		
0406	0105	4C3000		JMP	FINY	TACK ON A COMMA,Y
0407	0108					
0408	0108					
0409	0108		FBLOCK	ENTRY		BLOCK MOVE
0410	0108					
0411	0108	C220		REP	#M	
0412	010A	A588		LDA	OPRNDL	MAKE HUMAN-READABLE:
0413	010C	EB		XBA		SWAP SOURCE, DEST
0414	010D	8588		STA	OPRNDL	
0415	010F	E220		SEP	#M	
0416	0111					
0417	0111	200080		JSR	POB	OUTPUT THE SOURCE
0418	0114	A9AC		LDA	#','	THEN COMMA
0419	0116	990080		STA	LINE,Y	
0420	0119	C8		INY		
0421	011A	EB		XBA		SWAP DEST INTO OPRNDL
0422	011B	8588		STA	OPRNDL	THEN PRINT ONE BYTE
0423	011D	4C0080		JMP	POB	
0424	0120					
0425	0120					
0426	0120			END		

### Local Symbols

FABS	00001D	FABSIND	0000A7	FABSINXIND	0000D6	FABBSL	000020
FABSLX	000073	FABSX	00006D	FABSY	000079	FACC	000026
FBLOCK	000108	FDIR	000023	FDIRINXX	000054	FDIRINXY	00005A
FIMM	00000B	FIMP	00002C	FIND	000086	FINDINX	00002D
FINDINXL	00003C	FINDL	0000C6	FINX	000060	FINXIND	000042
FINY	000030	FPCR	00007F	FPCRL	000096	FSRINDINX	0000F6
FSTACK	0000E5	FSTACKREL	0000E6	GOSHORT	00001A	OK	00008B

## The Western Design Center

### POB

This routine (put operand byte), with three entry points, outputs a dollar sign, followed by either one, two, or three operand bytes in hexadecimal form; it calls the routine **PUTHEX** to output the operand bytes. It is called by **FRMOPRND**.

Depending on the entry point, the **X** register is loaded with 0, 1, or 2, controlling the number of times the loop at **MORE** is executed; on each iteration of the loop, an operand byte is loaded by indexing into **OPRNDL** and then printed by **PUTHEX**.

0427	0000				
0428	0000				
0429	0000				
0430	0000				
0431	0000				
0432	0000				
0433	0000				
0434	0000				
0435	0000				
0436	0000				
0437	0000				
0438	0000				
0439	0000				
0440	0000				
0441	0000				
0442	0000				
0443	0000	POB	START		
0444	0000		LONGA	OFF	
0445	0000		LONGI	OFF	
0446	0000				
0447	0000				
0448	0000	A200	LDX	#0	PRINT:
0449	0002	8006	BRA	IN	ONE OPERAND BYTE
0450	0004	PODB	ENTRY		SKIP
0451	0004	A201	LDX	#1	TWO OPERAND BYTES
0452	0006	8002	BRA	IN	SKIP
0453	0008	POTB	ENTRY		
0454	0008	A202	LDX	#2	THREE OPERAND BYTES
0455	000A				FALL THROUGH
0456	000A	A9A4	IN	LDA	#'\$'
0457	000C	990080	STA	LINE,Y	PRINT LEAD-IN
0458	000F	C8	INY		
0459	0010				
0460	0010	B588	MORE	LDA	OPRNDL,X
0461	0012	200080		JSR	PUTHEX
0462	0015	CA		DEX	LOOP THROUGH OPERAND
0463	0016	10F8		BPL	HIGH TO LOW
0464	0018	60		RTS	
0465	0019			END	
Local Symbols					
IN	00000A	MORE	000010	PODB	000004
				POTB	000008

**STEP**

This routine also contains the **PAUSE** entry point called by **LIST**; **STEP** waits until a keypress, **PAUSE** simply checks to see if a key has been pressed, and waits only if there has been an initial keypress. In both cases, the wait loop continues until the next keypress. If the keypress that exits the wait loop was the **ESCAPE** key, the carry is cleared, signalling the calling program that the user wants to quit rather than continue. If it was **RETURN**, the overflow flag is cleared; the tracer uses this toggle between tracing and single stepping. Any other keypress causes the routine to return with both flags set.

The code in this listing is machine-dependent; it checks the keyboard locations of the AppleII. Since this is a relatively trivial task, in-line code is used rather than a call to one of the existing 6502 monitor routines; therefore, the processor remains in the native mode while it performs this I/O operation.

Like all utility routines, **STEP** saves and restores the status on entry and exit.

0466	0000				
0467	0000				
0468	0000				
0464	0000				
0465	0000		APPEND DB.	UTILITY	
0466	0000				
0467	0000				
0468	0000				
0469	0000				
0470	0000				
0471	0000				
0472	0000		:	.....	
0473	0000		:		
0474	0000		:	STEP - - CHECKS FOR USER PAUSE SIGNAL	
0475	0000		:	(KEYSTROKE)	
0476	0000		:		
0477	0000		:	CONTAINS MACHINE-DEPENDENT CODE	
0478	0000		:	FOR APPLE I I	
0479	0000		:	.....	
0480	0000		:		
0481	0000				
0482	0000		STEP	START	
0483	0000		KEYBD	EQU	\$C000
0484	0000		KEYYSTB	EQU	\$C010
0485	0000		ESC	EQU	\$9B
0486	0000		V	EQU	\$40
0487	0000			LONGA	OFF
0488	0000			LONGI	OFF
0489	0000				
0490	0000	08		PHP	SAVE MODES
0491	0001	E230		SEP	#M+X
0492	0003	800B		BRA	WAIT
0493	0005				
0494	0005		PAUSE	ENTRY	ENTRY FOR 'PAUSE' CALL
0495	0005	08		PHP	
0496	0006	E230		SEP	#M+X
0497	0008	AD00C0		LDA	KEYBD
					CHECK FOR KEYPRESS
0498	000B	101B		BPL	RETNCR
0499	000D	8D10C0		STA	KEYSTB
					NONE; DON'T PAUSE
					CLEAR STROBE
0500	0010			:	IF KEYSTROKE
0501	0010	AD00C0	WAIT	LDA	KEYBD
					LOOP FOR NEXT KEY
0502	0013	10FB		BPL	WAIT
0503	0015	8D10C0		STA	KEYSTB
					CLEAR STROBE
0504	0018	C998		CMP	#ESC
					IF ESC RETURN WITH
0505	001A	D004		BNE	RETNEC

**The Western Design Center**

0506	001C						
0507	001C	28	RETEQ	PLP		CARRY CLEAR (QUIT)	
0508	001D	EA		NOP			
0509	001E	18		CLC			
0510	001F	60		RTS			
0511	0020						
0512	0020	C98D	RETDESC	CMP	#CR		
0513	0022	D004		BNE	RETNCR		
0514	0024	28		PLP			
0515	0025	E241		SEP	#C+V		
0516	0027	60		RTS			
0517	0028						
0518	0028	8D10C0	RETNCR	STA	KEYSTB		
0519	002B	28		PLP		ELSE SET	
0520	002C	38		SEC			
0521	002D	B8		CLV			
0522	002E	60		RTS			(CONTINUE)
0523	002F			END			
Local Symbols							
ESC	00009B	KEYBD	00C000	KEYSTB	00C010	PAUSE	000005
RETEQ	00001C	RETNCR	000028	RETDESC	000020	V	000040
WAIT	000010						

**PUTHEX**

This utility routine, already referred to in several descriptions, is called whenever a hexadecimal value needs to be output. It converts the character in the low byte of the accumulator into two hexadecimal characters, and stores them in the buffer **LINE** at the position pointed to by the **Y** register.

**PUTHEX** calls an internal subroutine, **MAKEHEX**, which does the actual conversion. This call (rather than in-line code) allows **MAKEHEX** to first call, then fall through into, an internal routine, **FORMNIB**.

When **MAKEHEX** returns, it contains the two characters to be printed in the high and low bytes of the accumulator; **MAKEHEX** was processed with the accumulator eight bits wide, so the sixteen-bit mode is switched to, letting both bytes be stored in one instruction. The **Y** register is incremented twice, pointing it to the space immediately past the second character printed.

**FORMNB** is both called (for processing the first nibble) and fallen into (for processing the second). Thus the **RTS** that exist exits **FORMNIB** returns variously to either **MAKEHEX** or **PUTHEX**. This technique results in more compact code than if **FORMNIB** were called twice.

The conversion itself is done by isolating the respective bits, and then adding the appropriate offset to form either the correct decimal or alphabetic (A-F) hexadecimal character.

Like all utility routines, the status is saved and restored on entry and exit.

0524	0000				
0525	0000				
0526	0000				
0527	0000				
0528	0000				
0529	0000				
0530	0000				
0531	0000				
0532	0000				
0533	0000				
0534	0000				
0535	0000				
0536	0000				
0537	0000				
0538	0000				
0539	0000		PUTHEX	START	
0540	0000	08		PHP	SAVE MODE FLAGS
0541	0001	200D00		JSR	MAKEHEX GET ASCII CODES A, B
0542	0004	C220		REP	#M
0543	0006			LONGA	ON
0544	0006	990080		STA	LINE,Y PUT TWO BYTES AT LINE
0545	0009	C8		INY	INCREMENT Y PAST THEM
0546	000A	C8		INY	
0547	000B	28		PLP	RESTORE MODE
0548	000C	60		RTS	RETURN
0549	000D				
0550	000D	E230	MAKEHEX	SEP	\$M+X ALL EIGHT BIT
0551	000F			LONGA	OFF
0552	000F			LONGI	OFF
0553	000F				
0554	000F	48		PHA	SAVE VALUE TO BE CONVERTED
0555	0010	290F		AND	#\$0F MASK OFF LOW NIBBLE
0556	0012	201B00		JSR	FORMNIB CONVERT TO HEX
0557	0015	EB		XBA	STORE IN B
0558	0016	68		PLA	RESTORE VALUE
0559	0017	4A		LSR	A SHIFT HIGH NIBBLE
0560	0018	4A		LSR	A TO LOW NIBBLE
0561	0019	4A		LSR	A
0562	001A	4A		LSR	A
0563	001B				
0564	001B				FALL THROUGH TO CONVERT
0565	001B	C90A	FORMNIB	CMP	#\$A IF GREATER THAN OR EQUAL TO
0566	001D	B004		BGE	HEXDIG 10, USE DIGITS A . . F

**The Western Design Center**

0567	001F	18		CLC		ELSE SIMPLY ADD '0' TO
0568	0020	69B0		ADC	#'0'	CONVERT TO ASCII
0569	0022	60		RTS		
0570	0023					
0571	0023	69B6	HEXDIG	ADC	\$'A'-11	SUBTRACT 11, ADD 'A'
0572	0025	60		RTS		(SORT OF)
0573	0026					
0574	0026			END		
Local Symbols						
FORMNIB		00001B		HEXDIG	000023	MAKEHEX 00000D

## The Western Design Center

### CLRLN

**CLRLN** performs the very straightforward task of clearing the output buffer, **LINE**, to blanks. It also contains the global storage reserved for **LINE**.

Like the other utility routines, **CLRLN** saves and restores the status.

0575	0000				
0576	0000				; .....
0577	0000				;
0578	0000				; CLRLN
0579	0000				;
0580	0000				; CLEARS 'LINE' WITH BLANKS
0581	0000				;
0582	0000				; SAVES AND RESTORES MODE FLAGS
0583	0000				;
0584	0000				; .....
0585	0000				;
0586	0000				;
0587	0000				
0588	0000		CLRLN	START	
0589	0000	08		PHP	
0590	0001	C230		REP	#M+X
0591	0003			LONGA	ON
0592	0003			LONGI	ON
0593	0003				
0594	0003	A9A0A0		LDA	#' '
0595	0006	A24400		LDX	#68
0596	0009				
0597	0009	9D1200	LOOP	STA	LINE,X
0598	000C	CA		DEX	
0599	000D	CA		DEX	
0600	000E	10F9		BPL	LOOP
0601	0010	28		PLP	
0602	0011	60		RTS	
0603	0012				
0604	0012				
0605	0012		LINE	ENTRY	
0606	0012	A0A0A0A0		DC	70C' '
0607	0058	8D00		DC	H'8D00'
0608	005A			END	
Local Symbols					
LINE	000012	LOOP	000009		



**UPDATE**

This routine, common to both the disassembler and the tracer, updates the program counter and other direct page variables – the address mode attribute (**ADDRMODE**) and the length (**OPLEN**) – and, using the length, reads the instruction operands into direct page memory.

The address mode and length attributes are stored in a table called **ATRIBL**, two bytes per instruction. Since there are 256 different codes, the table size is 512 bytes. The current opcode itself, fetched previously, is used as the index into the table. Since the table entries are two bytes each, the index is first multiplied by two by shifting left. Since the sixteen-bit accumulator was used to calculate the index, both attribute bytes can be loaded in a single operation; since their location in direct page memory is adjacent, they can be stored in a single operation as well.

Normally, the value of **OPLEN** loaded from the attribute table is the correct one; in the case of the immediate addressing mode, however, the length varies with the setting of the **m** and **x** flags. The opcode for the immediate instructions are trapped using just three comparisons, an **AND**, and four branches to test the opcode bits. Note that the immediate operands are multiplied times two because the opcode already happens to be shifted left once. If the current instruction uses immediate addressing, the stored value of the status register is checked for the relevant flag setting; if **m** or **x**, as appropriate, is clear, then **OPLEN** is incremented. The routines that output the immediate operand now know the correct number of operand bytes to print, and the tracer knows where the next instruction begins.

The status is saved on entry and restored on exit.

0609	0000				
0610	0000				
0611	0000				.....
0612	0000				;
0613	0000				; UPDATE
0614	0000				;
0615	0000				; UPDATES ATTRIBUTE VARIABLES BASED ON OPCODE
0616	0000				; PASSED IN ACCUMULATOR BY LOOKING IN ATTRIBUTE
0617	0000				; TABLES
0618	0000				;
0619	0000				; SAVES AND RESTORES MODE FLAGS
0620	0000				.....
0621	0000				;
0622	0000				
0623	0000				
0624	0000		UPDATE	START	
0625	0000			USING	ATRIBL
0626	0000				
0627	0000				
0628	0000		LDYI	EQU	\$A0+2
0629	0000		LDXI	EQU	\$A2+2
0630	0000				
0631	0000	08		PHP	
0632	0001	C230		REP	#M+X
0633	0003			LONGA	ON
0634	0003			LONGI	ON
0635	0003				
0636	0003	29FF00		AND	#\$FF
0637	0006	0A		ASL	A
0638	0007				
0639	0007	AS		TAY	
0640	0008	B90080		LDA	ATRIBL,Y
0641	000B	EB		XBA	
0642	000C	859C		STA	ADDRMODE
0643	000E				
0644	000E	AA		TAX	
0645	000F	98		TYA	
0646	0010	E210		SEP	#X
0647	0012			LONGI	OFF
0648	0012				

## The Western Design Center

0649	0012	BCFF7F		LDY	LENS-1,X	GET LENGTH OF OPERATION
0650	0015	849F		STY	OPLN	
0651	0017					
0652	0017					
0653	0017	A697		LDX	EBIT	EMULATION MODE?
0654	0019	E001		CPX	#1	TEST BIT ZERO
0655	001B	F02E		BEQ	SHORT	YES - - ALL IMMEDIATE ARE
0656	001D					SHORT
0657	001D	892000	;	BIT	#\$20	IS MSD+2 EVEN?
0658	0020	D029		BNE	SHORT	NO, CAN'T BE IMMEDIATE
0659	0022	C94401		CMP	#LDXI	IS IT LDX #?
0660	0025	F00A		BEQ	CHKX	
0661	0027	891E00		BIT	#\$F+2	IS LSD+2 ZERO?
0662	002A	D00E		BNE	CHKA	CHECK ACCUMULATOR OPCODES
0663	002C	C94001		CMP	PREG	MUST = LDY# OR GREATER
0664	002F	9009		BLT	CHKA	NO, MAYBE ACCUMULATOR
0665	0031	A596		LDA	PREG	IF IT IS, WHAT IS FLAG SETTING?
0666	0033	291000		AND	#X	
0667	0036	F011		BEQ	LONG	CLEAR - 16 BIT MODE
0668	0038	D011		BNE	SHORT	SET - 8 BIT MODE
0669	003A					
0670	003A	291E00	CHKA	AND	#\$0F+2	MASK OUT MSD
0671	003D	C91200		CMP	#\$9+2	IS LSD = 9?
0672	0040	D009		BNE	SHORT	
0673	0042	A596		LDA	PREG	WHAT IS FLAG SETTING?
0674	0044	292000		AND	#M	
0675	0047	D002		BNE	SHORT	NO, 8 BIT MODE
0676	0049					
0677	0049	E69F	LONG	INC	OPLN	LONG IMMEDIATE - - LENGTH IS
0678	004B		;			ONE MORE THEN FOUND IN TABLE
0679	004B					
0680	004B	A000	SHORT	LDY	#0	
0681	004D	8005		BRA	LOOPIN	
0682	004F					
0683	004F	A780	LOOP	[PCREG]		LOAD 16 BITS - - 16 BIT MODE
0684	0051		;			USED TO BUMP PCREG EASILY
0685	0051	AA		TAX		TRUNCATE TO EIGHT BITS
0686	0052	9687		STX	ORPNDL-1,Y	SAVE
0687	0054					
0688	0054	E680	LOOPIN	INC	PCREG	MOVE PC PAST NEXT INSTRUCTION
0689	0056	C8		INY		BYTE
0690	0057	C49F		CPY	OPLN	MOVED ALL OPERAND BYTES?
0691	0059	D0F4		BNE	LOOP	NO, CONTINUE
0692	005B					
0693	005B	28	DONE	PLP		
0694	005C	60		RTS		
0695	005D			END		
Local Symbols						
CHKA	00003A	CHKX	000031	DONE	00005B	LDXI 000144
LDYI	000140	LONG	000049	LOOP	00004F	LOOPIN 000054
SHORT	000048					

## The Western Design Center

### PRINTLN

This is the output routine. In this version, an existing 6502 output routine is called, necessitating a reversion to the emulation mode. Since this is the only place a 6502 routine is called, a simpler mode-switching routine than the generalized one of the previous chapter is used. The user registers do not need to be preserved, but zero needs to be swapped into the direct page to make it address page zero.

The main loop is in the emulation mode until the null terminal byte of **LINE** is encountered; on exit, the native mode, direct page, and status are restored.

0696	0000				
0697	0000				
0698	0000				; .....
0699	0000				;
0700	0000				; PRINTLN
0701	0000				;
0702	0000				; MACHINE-DEPENDENT CODE TO OUTPUT
0703	0000				; THE STRING STORED AT 'LINE'
0704	0000				;
0705	0000				; SAVES AND RESTORED MODE FLAGS
0706	0000				; .....
0707	0000				;
0708	0000				
0709	0000				
0710	0000				
0711	0000		PRINTLN	START	
0712	0000		COUT	EQU	\$FDED APPLE CHARACTER OUTPUT ROUTINE
0713	0000				
0714	0000	08		PHP	SAVE STATUS
0715	0001	0B		PHD	SAVE DIRECT PAGE
0716	0002	F40000		PEA	0 SWITCH TO PAGE ZERO
0717	0005	2B		PLD	FOR EMULATION
0718	0006				
0719	0006			LONGA	OFF
0720	0006			LONGI	OFF
0721	0006	38		SEC	SWITCH TO EMULATION
0722	0007	FB		XCE	
0723	0008				
0724	0008	A000		LDY	#0
0725	000A				
0726	000A	B90080	LOOP	LDA	LINE,Y LOOP UNTIL STRING TERMINATOR
0727	000D	F006		BEQ	DONE REACHED
0728	000F	20EDFD		JSR	COUT
0729	0012	C8		INY	
0730	0013	80F5		BRA	LOOP
0731	0015				
0732	0015	18	DONE	CLC	RESTORE NATIVE MODE
0733	0016	FB		XCE	
0734	0017	2B		PLD	RESTORE DIRECT PAGE
0735	0018	28		PLP	RESTORE MODE FLAGS
0736	0019	60		RTS	
0737	001A				
0738	001A			END	
Local Symbols					
COUT	00FDED	DONE	000015	LOOP	0000DA

## The Western Design Center

### TRACE

This is the actual entry to the trace routine. It performs initialization similar to **LIST**, and additionally sets up the **BRK** vectors, so they can point to locations within the tracer.

The **e** flag, direct page register and data bank register are all given initial values of zero. The program counter and program counter bank are presumed to have been initialized by the user. The first byte of the program to be traced is loaded; since indirect long addressing is used, this program can be used with the 65816 to debug programs located in any bank. It can, of course, also be used with the 65802.

The jump to **TBEGIN** enters the main loop of the trace routine in the middle – in other words, “between instructions.”

0739	0000				
0740	0000		APPEND DB.	TRACE	
0741	0000				
0742	0000				
0743	0000				
0744	0000			; TRACE	
0745	0000				
0746	0000			; ENTRY POINT FOR TRACER	
0747	0000				
0748	0000				
0749	0000				
0750	0000		TRACE	START	
0751	0000		USRBRKV	GEQU	\$3F0
0752	0000		BRKN	GEQU	\$FFE6
0753	0000				USER BRK VECTOR FOR APPLE //
0754	0000	08			NATIVE MODE BRK VECTOR
0755	0001	18		PHP	SAVE CALLING STATE
0756	0002	FB		CLC	
0757	0003	08		XCE	
0758	0004			PHP	
0759	0004	C210		REP	#\$10
0760	0006			LONGI	ON
0761	0006	F40000		PEA	0
0762	0009				OLD STACK BOUNDARY
0763	0009	BA		TSX	
0764	000A	8E3D00		STX	SAVSTACK
0765	000D				
0766	000D	F40003		PEA	DPAGE
0767	0010	2B		PLD	INITIALIZE DIRECT PAGE
0768	0011				
0769	0011	8691		STX	STACK
0770	0013				
0771	0013	E220		SEP	#\$20
0772	0015			LONGA	OFF
0773	0015				
0774	0014	A901		LDA	#1
0775	0017	8597		STA	EBIT
0776	0019	6493		STZ	DIRREG
0777	001B	6494		STZ	DIRREGH
0778	001D	6495		STZ	DBREG
0779	001F	649E		STZ	MNX+1
0780	0021				
0781	0021	9C0080		STZ	STEPCTRL
0782	0024				
0783	0024	A20080		LDX	#EBRKN
0784	0027	8EF003		STX	USRBRKV
0785	002A				PATCH BRK VECTORS
0786	002A	AEE6FF		LDX	BRKN
					TO POINT TO TRACE CODE
0787	002D	E000C0		CPX	#\$C000
0788	0030	9003		BLT	OK
					MAKE SURE IT'S RAM ON AN APPLE

## The Western Design Center

0789	0032	4C0080		JMP	QUIT	MIGHT AS WELL GIVE UP NOW . . .
0790	0035	8E3F00	OK	STX	USRBRKN	
0791	0038					
0792	0038	A780		LDA	[PCREG]	GET FIRST OPCODE
0793	003A	4C0080		JMP	TBEGIN	BEGIN !
0794	003D					
0795	003D		SAVSTACK	ENTRY		
0796	003D	0000		DS	2	
0797	003F		USRBRKN	ENTRY		
0798	003F	0000		DS	2	
0799	0041		SAVRAM	ENTRY		
0800	0041	0000		DS	2	
0801	0043			END		
Local Symbols						
OK	000035	SAVRAM	000041	SAVSTACK	00003D	USRBRKN 00003F

## EBRKIN

This is the main loop of the tracer. It has three entry points: one each for the emulation and native mode **BRK** vectors to point top, and a third (**TBEGIN**) which is entered when then program starts tracing and there is no “last instruction.” This entry provides the logical point to begin examining the tracing process.

**TRACE** has performed some initialization, having loaded the opcode of the first instruction to be traced into the accumulator. As with **FLIST**, **UPDATE** is called to update the program counter and copy the instruction attributes and operand into direct page memory. The routine **CHKSPLC** is then called to handle the flow-altering instructions' in these cases, it will modify **PCREG** to reflect the target address. In either case, the opcode of the *next* instruction is loaded, and a **BRK** instruction (a zero) is stored in its place, providing a means to regain control immediately after the execution of the current instruction.

The contents of the RAM pointed to by the (arbitrary) ROM values in the native mode **BRK** vector are temporarily saved, and the location is patched with a jump to the **NBRKIN** entry point.

The registers are then loaded with their user program values: these will have been preinitialized by **TRACE**, or will contain the values saved at the end of the execution of the previous instruction. Note the order in which the registers are loaded; some with direct page locations, others pushed onto the stack directly from direct page locations; then pull into the various registers. Once the user registers have been loaded with their values, they cannot be used for data movement. The **P** status register must be pulled last, to prevent any other instructions from modifying the flags.

The **e** bit is restored by loading the **P** register with a mask reflecting the value it should have; **e** is exchanged with the carry, and a second **PLP** instruction restores the correct status register values.

The routine exists via a jump indirect long through the “old” pcreg variable, which points to the current instruction. It will be reentered (at either **EBRKIN** or **NBRKIN**) when the **BRK** instruction that immediately follows the current instruction is executed.

Before this, however, the single instruction will be executed by the processor; any memory to be loaded or stored, or any registers to be changed by the instruction, will be modified.

After the **BRK** is executed, control returns to the tracer either at **EBRKIN**, if the user program was in emulation mode, or at **NBRKIN** if the user program was in native mode. The first thing that must be done is preserve the state of the machine as it was at the end of the instruction.

The **BRK** instruction has put the program counter bank (only in native mode), the program counter, and the status register on the stack. The program already knows the address of the next instruction, so the value on the stack can be disregarded. The status register is needed, however.

Entry to **EBRKIN** is from the Apple I I monitor user vector at \$3F0 and \$3F1. The Apple II monitor handles emulation mode **BRK** instructions by storing the register values to its own zero page locations; it pulls the program counter and status register from the stack and stores them, too. The code at **EBRKIN** dummies up a native mode post-**BRK** stack by first pushing three place-holder bytes, then loading the status register the form where the Apple Monitor stored it, and pushing it. The accumulator and **X** registers are re-loaded from monitor locations; **Y** has been left intact. A one is stored to variable **EBIT**, which will be used to restore the emulation mode when **EBRKIN** exists. The processor switches to native mode, and control falls through into **NBRKIN**, the native mode break handler.

With the stack in the correct state for both emulation mode and native mode entries, the routine proceeds to save the entire machine context. The register sizes are extended to sixteen bits to provide a standard size which encompasses the maximum size possible. The data bank and direct page registers are pushed onto the stack; the **DPAGE** value is pushed on immediately after, and pulled into the direct page, establishing the local direct page. With this in place, the **A**, **X**, and **Y** registers can be stored at their direct page locations. The register values pushed on the stack are picked off using stack-relative addressing. Since control is not returned by execution of an **RTI** (as is usual for interrupt processing), but instead is returned by means of a **JMP**, the stack must be cleaned up. Since seven bytes have been pushed, seven is added to the current stack pointer, and then saved at the direct page variable **STACK**. This being done, a small local stack region \$140 can be allocated.

The memory borrowed as a RAM native-mode **BRK** vector is restored.

The current line is then disassembled in the same manner as **LIST**. The register values just stored into memory are also displayed via the routine **DUMPREGS**.

## **The Western Design Center**

Once this is done, the effect has been achieved and the contents of the registers between instructions has been made visible. Before resuming execution of the program being traced, a check is made to see if the user wishes to quit, pause or step, or toggle between tracing and stepping.

Before returning to the **TBEGIN** entry, the **BRK** instruction stored at the location of the new “current” instruction is replaced with the saved opcode, the current program counter is moved to the old program counter, and the cycle begins again at **TBEGIN**.

# The Western Design Center

0802	0000				
0803	0000				.....
0804	0000				;
0805	0000				; EBRKIN, NBRKIN, TBGIN
0806	0000				;
0807	0000				; ENTRY POINTS FOR TRACER MAIN LOOP
0808	0000				; EBKIN AND NBKIN RECOVER CONTROL AFTER
0809	0000				; 'BRK' INSTRUCTION EXECUTED
0810	0000				; TBEGIN IS INITIAL ENTRY FROM 'TRACE'
0811	0000				;
0812	0000				.....
0813	0000				;
0814	0000				
0815	0000				
0816	0000	EBRKIN	START		ENTRY FROM EMULATION MODE
0817	0000				FOR TRACER
0818	0000				
0819	0000		LONG	OFF	
			A		
0820	0000		LONGI	OFF	
0821	0000				
0822	0000	F40000	PEA	0	
0823	0003	4848	PHA		
0824	0004	A548	LDA	\$48	APPLE I I MONITOR
0825	0006	48	PHA		LOCATIONS
0826	0007	A545	LDA	\$45	FOR P, AA
0827	0009	A646	LDX	\$46	AND X
0828	000B				
0829	000B				; note that if direct page is relocated
0830	000B				; in emulation mode, these locations
0831	000B				; will be used by monitor brk handler
0832	000B				
0833	000B	EE9703	INC	EBIT+DPAGE	MARK AS EMULATION MODE
0834	000E				
0835	000E	18	CLC		GO NATIVE
0836	000F	FB	XCE		
0837	0010				
0838	0010	NBRKIN	ENTRY		ENTRY FROM NATIVE MODE
0839	0010				FOR TRACER
0840	0010				
0841	0010	C230	REP	#M+X	
0842	0012		LONGA	ON	
0843	0012		LONGI	ON	
0844	0012				
0845	0012	8B	PHB		SAVE DATA BANK
0846	0013	0B	PHD		DIRECT PAGE
0847	0014	F40003	PEA	DPAGE	SWITCH TO APPLICATION
0848	0017	2B	PLD		DIRECT PAGE
0849	0018				
0850	0018	858F	STA	AREG	STASH USER REGISTERS
0851	001A	868B	STX	XREG	
0852	001C	848D	STY	YREG	
0853	001E				
0854	001E	A301	LDA	1,S	GET DIRECT PAGE VALUE
0855	0020	8593	STA	DIRREG	SAVED
0856	0022				
0857	0022	3B	TSC		CALCULATE TRUE STACK
0858	0023	18	CLC		(BEFORE BRK)
0859	0024	690700	ADC	#7	
0860	0027	8595	STA	STACK	SAVE AS STACK
0861	0029				
0862	0029	A303	LDA	3,S	SAVE DATA BANK, STATUS
0863	002B	8595	STA	DBREG	STATUS REGISTER
0864	002D				
0865	002D	A94001	LDA	#\$140	SET UP SMALL STACK
0866	0030	1B	TCS		



## The Western Design Center

0867	0031					
0868	0031	4B		PHK		MAKE DATA BANK = PROGRAM BANK
0869	0032	AB		PLB		
0870	0033	AE0080		LDX	USRBRKN	RESTORE BORROWED RAM
0871	0036	AD0180		LDA	SAVRAM+1	
0872	0039	9D0100		STA	!!1,X	
0873	003C	AD0080		LDA	SAVRAM	
0874	003F	9D0100		STA	!0,X	
0875	0042	200080		JSR	FLIST	FORMAT DISASSEMBLY LINE
0876	0045	200080		JSR	FRMOPRND	
0877	0048					
0878	0048	200080		JSR	PRINTLN	PRINT IT
0879	004B					
0880	004B	200080		JSR	CLRLN	
0881	004E	200080		JSR	DUMPREGS	OUPUT REGISTER VALUES
0882	0051	200080		JSR	PRINTLN	
0883	0054					
0884	0054	E220		SEP	#M	
0885	0056			LONGA	ON	
0886	0056					
0887	0056	C210		REP	STPCNTRL	
0888	0058			LONGI	DOPAUSE	
0889	0058					
0890	0058	2CE000		BIT		
0891	005B	300E		BMI		
0892	005D					
0893	005D	200080		JSR	STEP	STEP ONE AT A TIME
0894	0060	9068		BCC	QUIT	USER WANTS TO QUIT
0895	0062	5011		BVC	RESUME	WANTS TO KEEP STEPPING
0896	0064	A980		LDA	#\$80	HIT CR; WANTS TO TRACE, NOT
0897	0066	8DE000		STA	STPCNTRL	STEP - - SET FLAG
0898	0069	800A		BRA	RESUME	
0899	006B					
0900	006B	200080	DOPAUSE	JSR	PAUSE	TRACING; ONLY WAIT IF USER
0901	006E	905A		BCC	QUIT	HITS KEY
0902	0070	5003		BVC	RESUME	WANTS TO KEEP TRACING
0903	0072	9CE000		STZ	STPCNTRL	HIT CR; WANTS TO STEP, NOT
0904	0075		;			TRACE - - CLEAR FLAG
0905	0075					
0906	0075	A583	RESUME	LDA	NCODE	RESTORE ONLD 'NEXT'; IT'S ABOUT
0907	0077	8780		STA	[PCREG]	TO BE EXECUTED
0908	0079					
0909	0079		TBEGIN	ENTRY		
0910	0079	AB		TAY		SAVE THE CURRENT (ABOUT TO BE
0911	007A		;			EXECUTED) OPCODE
0912	007A					
0913	007A	A680		LDX	PCREG	REMEMBER WHERE YOU GOT IT FROM
0914	007C	8684		STX	OPCREG	PCREG POINTED TO IT AFTER
0915	007E	A582		LDA	PCREGB	PREVIOUS CALL TO UPDATE
0916	0080	8586		STA	OPCREGB	
0917	0082					
0918	0082	98		TYA		
0919	0083					
0920	0083	8587		STA	CODE	SAVE CURRENT OPCODE
0921	0085	200080		JSR	UPDATE	UPDATE PC TO POINT PAST THIS
0922	0088		;			INSTRUCTION
0923	0088		;			UPDATE ATTRIBUTE VARIABLES
0924	0088					
0925	0088	200080		JSR	CHKSPCL	CHECK TO SEE IF THIS CAUSES A
0926	008B		;			TRANSFER
0927	008B	A780		LDA	[PCREG]	GET NEXT OPCODE TO BE EXECUTED
0928	008D		;			(ON NEXT LOOP THROUGH)
0929	008D	8583		STA	NCODE	SAVE IT
0930	008F	A900		LDA	#0	PUT A BREAK (\$00) THERE TO
0931	0091		;			REGAIN CONTROL
0932	0091	8780		STA	[PCREG]	
0933	0093					
0934	0093		GO	ENTRY		

## The Western Design Center

0935	0093	C230	REP	#M+X	
0936	0095		LONGA	ON	
0937	0095		LONGI	ON	
0938	0095	AE0080	LDX	USRBRKIN	BORROW THIS RAM FOT A SECOND
0939	0098	BD0000	LDA	!0,X	
0940	009B	8D0080	STA	SAVRAM	
0941	009E	BD0100	LDA	!1,X	
0942	00A1	8D0180	STA	SAVRAM+1	
0943	00A4	A94C00	LDA	#\$4C	
0944	00A7	9D0000	STA	!0,X	
0945	00AA	A91000	LDA	#NBRKIN	
0946	00AD	9D0100	STA	!1,X	
0947	00B0	A561	LDA	STACK	RESTORE STACK
0948	00B2	1B	TCS		
0949	00B3	D495	PEI	(DBREG)	GET THIS STUFF ON STACK
0950	00B5	D496	PEI	(EBIT-1)	
0951	00B7	D493	PEI	(DIRREG)	
0952	00B9				
0953	00B9	6497	STZ	EBIT	ASSUME NATIVE MODE ON RETURN
0954	00BB				
0955	00BB	A58F	LDA	AREG	RESTORE USER REGISTERS
0956	00BD	A48D	LDY	YREG	
0957	00BF	A68B	LDX	XREG	
0958	00C1				
0959	00C1	2B	PLD		POP IT AWAY!
0960	00C2				
0961	00C2	28	PLP		
0962	00C3	28	PLP		
0963	00C4	FB	XCE		
0964	00C5				
0965	00C5	AB	PLB		
0966	00C6	28	PLP		
0967	00C7				
0968	00C7	DC8403	JMP	[DPAGE+OPCREG]	ON TO THE NEXT!
0969	00CA				
0970	00CA		ENTRY		QUIT
0971	00CA	E220	SEP	#\$20	
0972	00CC		LONGA	OFF	
0973	00CC				
0974	00CC	A583	LDA	NCODE	CLEAN UP OLD PATCH
0975	00CE	8780	STA	[PCREG]	
0976	00D0				
0977	00D0	C210	REP	#\$10	
0978	00D2		LONGI	ON	
0979	00D2				
0980	00D2	AE0080	LDX	SAVSTACK	GET ORIGINAL STACK POINTER
0981	00D5	E8	INX		
0982	00D6	E8	INX		
0983	00D7	9A	TXS		
0984	00D8				
0985	00D8	F40000	PEA	0	RESTORE ZERO PAGE
0986	00DB	2B	PLD		
0987	00DC				
0988	00DC	28	PLP		
0989	00DD	FB	XCE		
0990	00DE	28	PLP		
0991	00DF	60	RTS		
0992	00E0				
0993	00E0		ENTRY		STEPCTRL
0994	00E0	00	DS	1	
0995	00E1		END		

### Local Symbols

DOPAUSE	00006B	GO	000093	NBRKIN	000010	QUIT	0000CA
RESUME	000075	STEPCTRL	0000E0	TBEGIN	000079		

## CHKSPCL

This routine checks the opcode about to be executed to see if it will cause a transfer of control. Is it a branch, a jump, or a call? If it is any of the three, the destination of the transfer must be calculated and stored at **PCREG** so that a **BRK** instruction can be stored there to maintain control after the current instruction is executed.

A table that contains all of the opcodes which can cause a branch or jump (**SCODES**) is scanned. If a match with the current instruction is not found, the routine exits and tracing resumes.

If a match is found, the value of the index into the table is checked. The opcodes for all the branches are stored at the beginning of **SCODES**, so if the value of the index is less than 9, the opcode was a branch and can be handled by the same general routine.

The first thing that must be determined if the opcode is a branch is whether or not the branch will be taken. By shifting the index right (dividing by two) an index for each pair of different types of branches is obtained. This index is used to get a mask for the bit in the status register to be checked. The value shifted into the carry determines whether the branch is taken if the status bit is set or clear.

If a branch is not taken, the routine exits. If, however, a branch is taken, the new program counter value must be calculated by sign extending the operand and adding it to the current program counter.

Each of the other opcodes (jumps and calls) are dispatched to handler routines through a jump table. Since only the new program counter values must be calculated, jumps and calls with the same addressing mode can be handled by the same routine.

Breaks, co-processor calls, and **RTIs** are not handled at all; a more robust tracer would handle **BRKs** by letting breakpoints be set and cleared. Since the software interrupts are not implemented, and software tracing of hardware interrupts is impractical, **RTI** is left unimplemented. The program counter is incremented by one, causing these instructions to be bypassed completely.

All of the jumps and calls are straightforward. Long addressing is used to force the stack and indirect addressing modes to access bank zero. Also notice the way the data bank register is copied to the program counter bank for indirect indexed addressing. Finally, note how the long addressing modes call their absolute analogs as subroutines, then handle the bank byte.

# The Western Design Center

0996	0000					
0997	0000					
0998	0000					
0999	0000					; .....
1000	0000					; CHKSPCL
1001	0000					; .....
1002	0000					; CHECK CURRENT OPCODE (IN CODE) FOR SPECIAL CASES
						; - - INSTRUCTIONS WHICH TRANSFER CONTROL (JMP, BRA, ETC.)
						; .....
1003	0000					; .....
1004	0000					; ASSUMES SHORTA, LONGI - - CALLED BY EBRKIN
1005	0000					; .....
1006	0000					; .....
1007	0000					; .....
1008	0000					; .....
1009	0000		CHKSPCL	START		
1010	0000			LONGA	OFF	
1011	0000			LONGI	ON	
1012	0000					
1013	0000	A20000		LDX	#SCX-SCODES	
1014	0003	A587		LDA	CODE	
1015	0005					
1016	0005	DD0080	LOOP	CMP	SCODES,X	CHECK TO SEE IF CURRENT OPCODE
1017	0008	F004		BEQ	HIT	IS IN EXCEPTION TABLE
1018	000A	CA		DEX		
1019	000B	10F8		BPL	LOOP	
1020	000D	60		RTS		EXIT IF NOT
1021	000E					
1022	0003					
1023	0003	E210	HIT	SEP	#X	
1024	0010			LONGI	OFF	
1025	0010					
1026	0010	8A		TXA		IF INDEX WAS LESS THAN 9, IT'S
1027	0011	C909		CMP	#9	A BRANCH
1028	0013	B00F		BGE	NOTBR	
1029	0015					
1030	0015	4A		LSR	A	SEE IF 'ODD OR EVEN'
1031	0016	AA		TAX		
1032	0017	BD0080		LDA	PHASK,X	GET MASK TO SELECT CORRECT
1033	001A					PREG BIT
1034	001A	2596		AND	PREG	IS IT SET?
1035	001C					
1036	001C	B003		BCS	BBS	IF INDEX WAS ODD, BRANCH IF
1037	001E					PREG BIT IS SET
1038	001E	F00B		BEQ	DOBRANCH	ELSE IF EVEN, BRANCH IF CLEAR
1039	0020	60		RTS		
1040	0021					
1041	0021	D008	BBS	BNE	DOBRANCH	"BRANCH IF BIT SET"
1042	0023	60		RTS		
1043	0024					
1044	0024	0A	NOTBR	ASL	A	NOT A BRANCH INSTRUCTION;
1045	0025					MULTIPLY BY TWO
1046	0025	AA		TAX		AND INDEX INTO HANDLER JUMP
1047	0026					TABLE
1048	0026	C210		REP	#X	
1049	0028	7CEE7F		JMP	(SPJMP-18,X)	BIAS JUMP TABLE BY 9
1050	0028					
1051	0028		DOBRANCH	ENTRY		
1052	002B	A9FF		LDA	#\$FF	SET ACCUMULATOR BYTE HIGH
1053	002D					(ANTICIPATE NEGATIVE)
1054	002D	EB		XBA		AND SIGN EXTEND INTO X
1055	002E					
1056	002E	A588		LDA	OPRNDL	
1057	0030					

## The Western Design Center

1058	0030	C231		REP	#M+X+C	MAKE REGS LONG; CLEAR CARRY
1059	0032			LONGA	ON	(ANTICIPATE ADC)
1060	0032			LONGI	ON	
1061	0032					
1062	0032	3003		BMI	OK	NUMBER WAS NEGATIVE; ALL IS OK
1063	0034					
1064	0034	297F00		AND	#\$7F	CLEAR HIGH BYTE OF ACCUM
1065	0037					(POSITIVE NUMBER)
1066	0037	6580	;	ADC	PCREG	
1067	0039	8580	OK	STA	PCREG	
1068	003B	E220		SEP	#M	RETURN WITH ACCUM SHORT
1069	003D	60		RTS		
1070	003E			END		

### Local Symbols

BBS	000021	DOBRANCH	00002B	HIT	00000E	LOOP	000005
NOTBR	000024	OK	000037				

1071	0000						
1072	0000		SBRK	START			THESE ARE NOT IMPLEMENTED!
1073	0000		SRTI	ENTRY			(AN EXERCISE FOR READER)
1074	0000		SCOP	ENTRY			
1075	0000	60		RTS			
1076	0001						
1077	0001		SJSRABS	ENTRY			ABSOLUTES - -
1078	0001		SJMPABS	ENTRY			
1079	0001	A688		LDX	OPRNDL		MOVE OPERAND TO PC
1080	0003	8680		STX	PCREG		
1081	0005	60		RTS			
1082	0006						
1083	0006		SBRL	ENTRY			LONG BRANCH
1084	0006	C221		REP	#M+C		LONG ACCUM AND CLEAR CARRY
1085	0008			LONGA	ON		
1086	0008	A588		LDA	OPRNDL		ADD DISPLACMENT TO
1087	000A	6580		ADC	PCREG		PROGRAM COUNTER
1088	000C	8580		STA	PCREG		
1089	000E	E220		SEP	#M		
1090	0010			LONGA	OFF		
1091	0010	60		RTS			
1092	0011						
1093	0011		SJSRABSL	ENTRY			ABSOLUTE LONGS
1094	0011		SJMPABSL	ENTRY			
1095	0011	A688		LDX	OPRNDL		MOVE OPERAND, INCLUDING BANK,
1096	0013	8680		STX	PCREG		TO PROGRAM COUNTER
1097	0015	A58A		LDA	OPRNDL		
1098	0017	8582		STA	PCREGB		
1099	0019	60		RTS			
1100	001A						
1101	001A		SRTS	ENTRY			RETURN
1102	001A	A691		LDX	STACK		PEEK ON STACK
1103	001C	EC0080		CPX	SAVSTACK		IF ORIGINAL STACK . . .
1104	001F	D003		BNE	CONT		
1105	0021	4C0080		JMP	QUIT		RETURN TO MONITOR
1106	0024	E8	CONT	INX			
1107	0025						
1108	0025	C220		REP	#M		
1109	0027	BF000000		LDA	>0,X		ALWAYS IN BANK ZERO
1110	002B	1A		INC	A		ADD ONE TO GET TRUE RETURN
1111	002C	8580		STA	PCREG		VALUE
1112	002E	E220		SEP	#M		
1113	0030						
1114	0030	60		RTS			
1115	0031						
1116	0031						
1117	0031		SRTL	ENTRY			RETURN LONG

# The Western Design Center

1118	0031	201A00		JSR	SRTS	DO NORMAL RETURN,	
1119	0034						
1120	0034	E8		INX		THEN GET BANK BYTE	
1121	0035	E8		INX			
1122	0036	BF000000		LDA	>0,X	A IS NOW SHORT FOR BANK BYTE	
1123	003A	8582		STA	PCREGB		
1124	003C	60		RTS			
1125	003D						
1126	003D						
1127	003D		SJMPIND	ENTRY		INDIRECT	
1128	003D	A688		LDX	OPRNDL	GET OPERAND	
1129	003F						
1130	003F	C220		REP	#M		
1131	0041	BF000000		LDA	>0,X	JMP IND ALWAYS IN BANK ZERO	
1132	0045	8580		STA	PCREG		
1133	0047	E220		SEP	#M		
1134	0049	60		RTS			
1135	004A						
1136	004A						
1137	004A		SJMPINDL	ENTRY			
1138	004A	203D00		JSR	SJMPIND	SAME AS JMP INDIRECT,	
1139	004D	E8		INX		PLUS BANK BYTE	
1140	004E	E8		IJNX			
1141	004F	BF000000		LDA	>0,X	ACCUM IS SHORT NOW	
1142	0053	8582		STA	PCREGB		
1143	0055	60		RTS			
1144	0056						
1145	0056						
1146	0056		SJMPINDEX	ENTRY		INDEX JUMPS	
1147	0056		SJSRINDEX	ENTRY			
1148	0056	A48B		LDY	XREG	LET CPU DO ADDITION	
1149	0058	A688		LDX	OPRNDL	GET INSIRECT POINTER	
1150	005A	8699		STX	TEMP		
1151	005C	A582		LDA	RCREGB	INDEXED JUMPS ARE IN PROGRAM	
1152	005E	859B		STA	TEMP+2	BANK	
1153	0060						
1154	0060	C220		REP	#M		
1155	0062	B799		LDA	[TEMP],Y	'Y IS X'	
1156	0064	8680		STA	PCREG		
1157	0066	E220		SEP	#M		
1158	0068						
1159	0068	60		RTS			
1160	0069						
1161	0069						
1162	0069			END			
Local Symbols							
CONT	000024	SBRL	000006	SCOP	000000	SJMPABS	000001
SJMPABSL	000011	SJMPIND	00003D	SJMPINDL	00004A	SJMPINDEX	000056
SJSRABS	000001	SJSRABSL	000011	SJSRINDEX	000056	SRTI	000000
SRTL	000031	SRTS	00001A				

DUMPREGS

This routine forms an output line that will display the contents of the various registers. The routine is driven in a loop by a table containing single-character register names (“A,” “X,” and so on) and the address of the direct page variable that contains the corresponding register value. It is interesting in that a direct page pointer to a direct page address is used, since the two index registers are occupied with accessing the table entries and pointing to the next available location in the output buffer.

1163	0000				
1164	0000				
1165	0000				; .....
1166	0000				;
1167	0000				; DUMPREGS
1168	0000				;
1169	0000				; DISPLAYS CONTENTS OF REGISTER VARIABLES IN 'LINE'
1170	0000				;
1171	0000				; SAVES AND RESTORES MODE
1172	0000				; .....
1173	0000				;
1174	0000				
1175	0000		DUMPREGS	START	
1176	0000	08		PHP	
1177	0001	E230		SEP	#M+X
1178	0003			LONGA	OFF
1179	0003			LONGI	OFF
1180	0003				
1181	0003	A000		LDY	#0
1182	0005				
1183	0005	A903		LDA	#>DPAGE STO E DPAGE HIGH IN TEMP HIGH
1184	0007	859A		STA	TEMPH
1185	0009				
1186	0009	A209		LDX	#ENDTABLE-TABLE LENGTH OF COMMAND TABLE
1187	000B				
1188	000B	BD4400	LOOP	LDA	TABLE,X GET ADDRESS OF NEXT REGISTER
1189	000E	8599		STA	TEMP
1190	0010	CA		DEX	
1191	0011	BD4400		LDA	TABLE,X GET REGISTER 'NAME'
1192	0014	200080		JSR	PUTREG16
1193	0017	CA		DEX	
1194	0018	10F1		BPL	LOOP
1195	001A				
1196	001A	1995		LDA	#DBREG NOW ALL THE 8-BIT REGISTERS
1197	001C	8599		STA	TEMP
1198	001E	A9C2		LDA	#'B'
1199	0020	200080		JSR	PUTREG8
1200	0023	A996		LDA	#PREG
1201	0025	8599		STA	TEMP
1202	0027	A9D0		LDA	#'P'
1203	0029	200080		JSR	PUTREG8
1204	002C	A9C5		LDA	#'E'
1205	002E	990080		STA	LINE,Y
1206	0031	C8		INY	
1207	0032	A9BA		LDA	#':'
1208	0034	990080		STA	LINE,Y
1209	0037	C8		INY	
1210	0038				
1211	0038	A9B0		LDA	#'0'
1212	003A	A697		LDX	EBIT
1213	003C	F001		BEQ	OK
1214	003E	1A		INC	A '0' BECOMES '1'
1215	003F	990080	OK	STA	LINE,Y
1216	0042				

**The Western Design Center**

1217	0042						
1218	0042	28		PLP			
1219	0043	60		RTS			
1220	0044						
1221	0044	C494	TABLE	DC	C'D',I1'DIRREGH'	DIRECT PAGE	
1222	0046	D392		DC	C'S',I1'STACKH'	ADDRESS OF	
1223	0048	D98E		DC	C'Y',I1'YREGH'	REGISTER	
1224	004A	D88C		DC	C'X',I1'XREGH'	VARIABLES	
1225	004C	C1		DC	C'A'		
1226	004D	90	ENDTABLE	DC	I1'AREGH'		
1227	004E			END			
Local Symbols							
ENDTABLE	00004D	LOOP	00000B	OK	00003F	TABLE	000044



## The Western Design Center

### PUTRTEG8

This routine, along with **PUTREG16**, is called by **DUMPREGS** to actually output a register value once its label and storage location have been loaded from the table. Naturally, it calls **PUTREX** to convert the register values to hexadecimal.

1228	0000				
1229	0000				
1230	0000				
1231	0000				
1232	0000				
1233	0000				
1234	0000				
1235	0000				
1236	0000				
1237	0000				
1238	0000				
1239	0000	PUTREG8	START		
1240	0000	990080	STA	LINE,Y	A CONTAINS REGISTER 'NAME'
1241	0003	C8	INY		
1242	0004	A9BC	LDA	#='	EQUALS . .
1243	0006	990080	STA	LINE,Y	
1244	0009	C8	INY		
1245	000A	8012	BRA	PRIN	USE PUTREG16 CODE
1246	000C				
1247	000C	PUTREG16	ENTRY		
1248	000C	990080	STA	LINE,Y	A CONTAINS REGISTER 'NAME'
1249	000F	C8	INY		
1250	0010	A9BD	LDA	#='	EQUALS . .
1251	0012	990080	STA	LINE,Y	
1252	0015	C8	INY		
1253	0016	C8	INY		
1254	0017	B299	LDA	(TEMP)	TEMP POINTS TO REGISTER
1255	0019	C699	DEC	TEMP	VARIABLE HIGH
1256	001B	200080	JSR	PUTHEX	
1257	001E				
1258	001E	C8	PRIN	INY	
1259	001F	B299	LDA	(TEMP)	TEMP POINTS TO REGISTER
1260	0021	200080	JSR	PUTHEX	VARIABLE LOW (OR 8 BIT)
1261	0024	C8	INY		
1262	0025	60	RTS		
1263	0026		END		
Local Symbols					
PRIN	0000IE	PUTREG16	00000C		

## **TABLES**

The next several pages list the tables used by the program – **SPJMP**, **PMASK**, **SCODES**, **MN**, **MODES**, **LENS**, and **ATRIBL**.

**SPJMP** is a jump table of entry points to the trace handlers for those instructions which modify the flow of control.

**PMASK** contains the masks used to check the status of individual flag bits to determine if a branch will be taken.

**SCODES** is a table containing the opcodes of the special (flow-altering) instructions.

**ATRBL** is the attribute table for all 256 opcodes. Each table entry is two bytes, one is an index into the mnemonic table, the other the address mode. This information is the key to the other tables, all used by the **UPDATE** routine, which puts a description of the current instruction's attributes into the respective direct page variables. **MN** is the table of instruction mnemonics that the 'mnemonic index' attribute points into. **MODES** is a jump table with addresses of the disassembly routine for each addressing mode, and **LENS** contains the length of instructions for each addressing mode. Both of these tables are indexed into directly with the 'address mode' attribute.

# The Western Design Center

1264	0000				
1265	0000				.....
1266	0000				;
1267	0000				; SP JMP
1268	0000				; JUMP TABLE FOR 'SPECIAL' OPCODE HANDLERS
1269	0000				.....
1270	0000				;
1271	0000				
1272	0000		SPJMP	START	JUMP TABLE FOR
1273	0000	0080		DC	A'SBRK'
1274	0002	0080		DC	A'SJSRABS'
1275	0004	0080		DC	A'SRTI'
1276	0006	0080		DC	A'SRTS'
1277	0008	0080		DC	A'SCOP'
1278	000A	0080		DC	A'SJSRABSL'
1279	000C	0080		DC	A'SBRL'
1280	000E	0080		DC	A'SRTL'
1281	0010	0080		DC	A'SJMPABS'
1282	0012	0080		DC	A'SJMPABSL'
1283	0014	0080		DC	A'SJMPIND'
1284	0016	0080		DC	A'SJMPINDX'
1285	0018	0080		DC	A'SJMPINDL'
1286	001A	0080	SCT	DC	A'SJSRINDX'
1287	001C				
1288	001C		END		
Local Symbols					
SCT		00001A			
1289	0000				
1290	0000				
1291	0000				
1292	0000				.....
1293	0000				;
1294	0000				; PMASK
1295	0000				; STATUS REGISTER MASKS FOR BRANCH HANDLING CODE
1296	0000				.....
1297	0000				;
1298	0000				
1299	0000		PMASK	START	MASKS FOR STATUS REGISTER
1300	0000	80		DC	H'80'
1301	0001	40		DC	H'40'
1302	0002	01		DC	H'01'
1303	0003	02		DC	H'02'
1304	0004	00		DC	H'00'
1305	0005			END	
1306	0000				
1307	0000				
1308	0000				
1309	0000				
1310	0000				
1311	0000		SCODES	START	SPECIAL OPCODES
1312	0000				
1313	0000	10		DC	H'10'
1314	0001	30		DC	H'30'
1315	0002	50		DC	H'50'
1316	0003	70		DC	H'70'
1317	0004	90		DC	H'90'
1318	0005	B0		DC	H'B0'
1319	0006	D0		DC	H'D0'
1320	0007	F0		DC	H'F0'

## The Western Design Center

1321	0008	80		DC	H'80'	BRA	
1322	0009	00		DC	H'00'	BRK	
1323	000A	20		DC	H'20'	JSR	
1324	000B	40		DC	H'40'	RTI	
1325	000C	60		DC	H'60'	RTS	
1326	000D	02		DC	H'02'	COP	
1327	000E	22		DC	H'22'	JSR	ABSL
1328	000F	82		DC	H'82'	BRL	
1329	0010	6B		DC	H'6B'	RTL	
1330	0011	4C		DC	H'4C'	JMP	ABS
1331	0012	5C		DC	H'5C'	JMP	ABSL
1332	0013	6C		DC	H'6C'	JMP	()
1333	0014	7C		DC	H'7C'	JMP	(,X)
1334	0015	DC		DC	H'DC'	JMP	[]
1335	0016		SCX	ENTRY			
1336	0016	FC		DC	H'FC'	JSR	(,X)
1337	0017			END			

### Local Symbols

SCX            000016

1138    0000                            APPEND DB. TABLE

1139    0000

1340    0000

1341    0000                            MN            DATA

1342    0000    000000                            DX            3

1343    0003    C1C4C3                            DC            C'ADC'            1

1344    0006    C1C3C4                            DC            C'AND'            2

1345    0009    C1D3CC                            DC            C'ASL'            3

1346    000C    C2C3C3                            DC            C'BCC'            4

1347    000F    C2C3D3                            DC            C'BCS'            5

1348    0012    C2C5D1                            DC            C'BEQ'            6

1349    0015    C2C9D4                            DC            C'BIT'            7

1350    0018    C2CDC9                            DC            C'BMI'            8

1351    001B    C2C3C5                            DC            C'BNE'            9

1352    001E    C2D0CC                            DC            C'BPL'            10

1353    0021    C2D2CB                            DC            C'BRK'            11

1354    0024    C2D6C3                            DC            C'BVC'            12

1355    0027    C2D6D3                            DC            C'BVS'            13

1356    002A    C3CCC3                            DC            C'CLC'            14

1357    002D    C3CCC4                            DC            C'CLD'            15

1358    0030    C3CCC9                            DC            C'CLI'            16

1359    0033    C3CCD6                            DC            C'CLV'            17

1360    0036    C3CDD0                            DC            C'CMP'            18

1361    0039    C3D0D8                            DC            C'CPX'            19

1362    003C    C3D0D9                            DC            C'CPY'            20

1363    003F    C4C5C3                            DC            C'DEC'            21

1364    0042    C4C5D8                            DC            C'DEX'            22

1365    0045    C4C5D9                            DC            C'DEY'            23

1366    0048    C5CFD2                            DC            C'EOR'            24

1367    004B    C9CEC3                            DC            C'INC'            25

1368    004E    C9C3D8                            DC            C'INX'            26

1369    0051    C9C3D9                            DC            C'INY'            27

1370    0054    CACDD0                            DC            C'JMP'            28

1371    0057    CAD3D2                            DC            C'JSR'            29

1372    005A    CCC4C1                            DC            C'LDA'            30

1373    005D    CCC4D8                            DC            C'LDX'            31

1374    0060    CCC9D9                            DC            C'LDY'            32

1375    0063    CDC3D2                            DC            C'LSR'            33

1376    0066    CECFD0                            DC            C'NOP'            34

1377    0069    CFD2C1                            DC            C'ORA'            35

1378    006C    D0C8C1                            DC            C'PHA'            36

1379    006F    D0C8D0                            DC            C'PHP'            37

## The Western Design Center

1380	0072	D0CCC1	DC	C'PLA'	38
1381	0075	D0CCD0	DC	C'PLP'	39
1382	0078	D2CFCC	DC	C'ROL'	40
1383	007B	D2CFD2	DC	C'ROR'	41
1384	007E	D2D4C9	DC	C'RIT'	42
1385	0081	D2D4D3	DC	C'RTS'	43
1386	0084	D3C2C3	DC	C'SBC'	44
1387	0087	D3C5C3	DC	C'SEC'	45
1388	008A	D3C5C4	DC	C'SED'	46
1389	008D	D3C5C9	DC	C'SEI'	47
1390	0090	D3D4C1	DC	C'STA'	48
1391	0093	D3D4D8	DC	C'STX'	49
1392	0096	D3D4D9	DC	C'STY'	50
1393	0099	D4C1D8	DC	C'TAX'	51
1394	009C	D4C1D9	DC	C'TAY'	52
1395	009F	D4D3D8	DC	C'TSX'	53
1396	00A2	D4D8C1	DC	C'TXA'	54
1397	00A5	D4D8D3	DC	C'TXS'	55
1398	00A8	D4D9C1	DC	C'TYA'	56
1399	00AB	C2D2C1	DC	C'BRA'	57
1400	00AE	D0CCD8	DC	C'PLX'	58
1401	00B1	D0CCD9	DC	C'PLY'	59
1402	00B4	D0C8D8	DC	C'PHX'	60
1403	00B7	D0D8D0	DC	C'PHY'	61
1404	00BA	D3D4DA	DC	C'STZ'	62
1405	00BD	D4D3C2	DC	C'TRB'	63
1406	00C0	D4D3C2	DC	C'TSB'	64
1407	00C3				
1408	00C3	D0C5C1	DC	C'PEA'	65
1409	00C6	D0C5C9	DC	C'PEI'	66
1410	00C9	D0C5D2	DC	C'PER'	67
1411	00CC	D0CCC2	DC	C'PLB'	68
1412	00CF	D0CCC4	DC	C'PLD'	69
1413	00D2	D0C8C2	DC	C'PHB'	70
1414	00D5	D0C8C4	DC	C'PHD'	71
1415	00D8	D0C8CB	DC	C'PHK'	72
1416	00DB				
1417	00DB	D2C5D0	DC	C'REP'	73
1418	00DE	D3C5D0	DC	C'SEP'	74
1419	00E1				
1420	00E1	D4C3C4	DC	C'TCD'	75
1421	00E4	D4C4C3	DC	C'TDC'	76
1422	00E7	D4C3D3	DC	C'TCS'	77
1423	00EA	D4D3C3	DC	C'TSC'	78
1424	00ED	D4D8D9	DC	C'TXY'	79
1425	00F0	D4D9D8	DC	C'TYX'	80
1426	00F3	D8C2C1	DC	C'XBA'	81
1427	00F6	D8C3C5	DC	C'XCE'	82
1428	00F9				
1429	00F9	C2D2CC	DC	C'BRL'	83
1430	00FC	CAD3CC	DC	C'JSL'	84
1431	00FF	D2D4CC	DC	C'RTL'	85
1432	0102	CDD6CE	DC	C'MVN'	86
1433	0105	CDD6D0	DC	C'MVP'	87
1434	0108	C3CFD0	DC	C'COP'	88
1435	010B	D7C1C9	DC	C'WAI'	89
1436	010E	D3D4D0	DC	C'STP'	100
1437	0111	D7C4CD	DC	C'WDM'	101
1438	0114		END		
1439	0000				
1440	0000		MODES	DATA	
1441	0000	0000	DS	2	
1442	0002	0080	DC	A'FIMM'	1
1443	0004	0080	DC	A'FABS'	2
1444	0006	0080	DC	A'FABSL'	3

## The Western Design Center

1445	0008	0080		DC	A'FDIR'	4	
1446	000A	0080		DC	A'FACC'	5	
1447	000C	0080		DC	A'FIMP'	6	
1448	000E	0080		DC	A'FINDINX'	7	
1449	0010	0080		DC	A'FINDINXL'	8	
1450	0012	0080		DC	A'FINXIND'	9	
1451	0014	0080		DC	A'FDIRINXX'	10	
1452	0016	0080		DC	A'FDIRINXY'	11	
1453	0018	0080		DC	A'FABSX'	12	
1454	001A	0080		DC	A'FABSLX'	13	
1455	001C	0080		DC	A'FABSY'	14	
1456	001E	0080		DC	A'FPCR'	15	
1457	0020	0080		DC	A'FPCRL'	16	
1458	0022	0080		DC	A'FABSIND'	17	
1459	0024	0080		DC	A'FIND'	18	
1460	0026	0080		DC	A'FINDL'	19	
1461	0028	0080		DC	A'FABSINXIND'	20	
1462	002A	0080		DC	A'FSTACK'	21	
1463	002C	0080		DC	A'FSTACKREL'	22	
1464	002E	0080		DC	A'FSRINDINX'	23	
1465	0030	0080		DC	A'FBLOCK'	24	
1466	0032						
1467	0032			END			
1468	0000						
1469	0000		LENS	START			
1470	0000	02		DC	H'02'	IMM	
1471	0001	03		DC	H'03'	ABS	
1472	0002	04		DC	H'04'	ABS LONG	
1473	0003	02		DC	H'02'	DIRECT	
1474	0004	01		DC	H'01'	ACC	
1475	0005	01		DC	H'01'	IMPLIED	
1476	0006	02		DC	H'02'	DIR IND INX	
1477	0007	02		DC	H'02'	DIR IND INX L	
1478	0008	02		DC	H'02'	DIR INX IND	
1479	0009	02		DC	H'02'	DIR INX X	
1480	000A	02		DC	H'02'	DIR INX Y	
1481	000B	03		DC	H'03'	ABS X	
1482	000C	04		DC	H'04'	ABS L X	
1483	000D	03		DC	H'03'	ABS Y	
1484	000E	02		DC	H'02'	PCR	
1485	000F	03		DC	H'03'	PCR L	
1486	0010	03		DC	H'03'	ABS IND	
1487	0011	02		DC	H'02'	DIR IND	
1488	0012	02		DC	H'02'	DIR IND L	
1489	0013	03		DC	H'03'	ABS INX IND	
1490	0014	01		DC	H'01'	STACK	
1491	0015	02		DC	H'02'	SR	
1492	0016	02		DC	H'02'	SR INX	
1493	0017	03		DC	H'03'	MOV	
1494	0018			END			
1495	0000						
1496	0000			APPEND DB. ATRIB			
1497	0000						
1498	0000		ATRIBL	DATA			
1499	0000						
1500	0000	0B06		DC	I1'11,6'	BRK	00
1501	0002	2309		DC	I1'35,9'	ORA D,X	01
1502	0004	5804		DC	I1'88,4'	COP (REALLY 2)	02
1503	0006	2316		DC	I1'35,22'	ORA-,X	03
1504	0008	4004		DC	I1'64,4'	TSB D	04
1505	000A	2304		DC	I1'34,4'	ORA D	05
1506	000C	0304		DC	I1'3,4'	ASL D	06
1507	000E	2313		DC	I1'35,19'	ORA [D]	07
1508	0010	2515		DC	I1'37,21'	PHP	08
1509	0012	2301		DC	I1'35,1'	ORA IMM	09

## The Western Design Center

1510	0014	0305	DC	II'3,5'	ASL ACC	0A
1511	0016	4715	DC	II'71,21'	PHD	0B
1512	0018	4002	DC	II'64,2'	TSB ABS	0C
1513	001A	2302	DC	II'35,2'	ORA ABS	0D
1514	001C	0302	DC	II'3,2'	ASL ABS	0E
1515	001E	2303	DC	II'35,3'	ORA ABS L	0F
1516	0020	0A0F	DC	II'10,15'	BPL	10
1517	0022	2307	DC	II'35,7'	ORA (D),Y	11
1518	0024	2312	DC	II'35,18'	ORA (D)	12
1519	0026	2317	DC	II'35,23'	ORA S,Y	13
1520	0028	3FO4	DC	II'63,4'	TRB D	14
1521	002A	230A	DC	II'35,10'	ORA D,X	15
1522	002C	030A	DC	II'3,10'	ASL D,X	16
1523	002E	2308	DC	II'35,8'	ORA (DL),Y	17
1524	0030	0E06	DC	II'14,6'	CLC	18
1525	0032	230E	DC	II'35,14'	ORA ABS,Y	19
1526	0034	1905	DC	II'25,5'	NC ACC	1A
1527	0036	4D06	DC	II'77,6'	TCS	1B
1528	0038	3F02	DC	II'63,2'	TRB ABS,X	1C
1529	003A	230C	DC	II'35,12'	ORA ABS,X	1D
1530	003C	030C	DC	II'3,12'	ASL ABS,X	1E
1531	003E	230D	DC	II'35,13'	ORA ABSL,X	1F
1532	0040	1D02	DC	II'29,2'	JSR ABS	20
1533	0042	0207	DC	II'2,7'	AND (D, X)	21
1534	0044	1D03	DC	II'29,3'	JSL ABS L	22
1535	0046	0216	DC	II'2,22'	AND SR	23
1536	0048	0704	DC	II'7,4'	BIT D	24
1537	004A	0204	DC	II'2,4'	AND D	25
1538	004C	2804	DC	II'40,4'	ROL D	26
1539	004E	0213	DC	II'2,19'	AND (DL)	27
1540	0050	2706	DC	II'39,6'	PLP	28
1541	0052	0201	DC	II'2,1'	AND IMM	29
1542	0054	2805	DC	II'40,5'	ROL ACC	2A
1543	0056	4515	DC	II'69,21'	PLD	2B
1544	0058	0705	DC	II'7,2'	BIT ABS	2C
1545	005A	0202	DC	II'2,2'	AND ABS	2D
1546	005C	28005	DC	II'40,5'	ROL A	2E
1547	005E	0203	DC	II'2,3'	AND ABS L	2F
1548	0060	080F	DC	II'8,15'	BMI	30
1549	0062	020B	DC	II'2,11'	AND D,Y	31
1550	0064	0212	DC	II'2,18'	AND (D)	32
1551	0066	0217	DC	II'2,23'	AND (SR),Y	33
1552	0068	070A	DC	II'7,10'	BIT D,X	34
1553	006A	020A	DC	II'2,10'	AND D,X	35
1554	006C	280A	DC	II'40,10'	ROL D,X	36
1555	006E	0208	DC	II'2,8'	AND (DL),Y	37
1556	0070	2D06	DC	II'45,6'	SEC	38
1557	0072	020E	DC	II'25,14'	AND ABS,Y	39
1558	0074	1505	DC	II'21,5'	DEC	3A
1559	0076	4E06	DC	II'78,6'	TSC	3B
1560	0078	070C	DC	II'7,12'	BIT A,X	3C
1561	007A	020C	DC	II'2,12'	AND ABS,X	3D
1562	007C	280C	DC	II'40,12'	ROL A,X	3E
1563	007E	020D	DC	II'2,13'	AND AL,X	3F
1564	0080	2A06	DC	II'42,6'	RTI	40
1565	0082	1809	DC	II'24,9'	EOR (D,X)	41
1566	0084	6506	DC	II'101,6'	WDM	42
1567	0086	1816	DC	II'24,22'	EOR (D,X)	43
1568	0088	5718	DC	II'87,24'	MVP	44
1569	008A	1804	DC	II'24,4'	EOR D	45
1570	008C	2104	DC	II'33,4'	LSR D	46
1571	008E	1813	DC	II'24,19'	EOR (DL)	47
1572	0090	2406	DC	II'36,6'	PHA	48
1573	0092	1801	DC	II'24,1'	EOR IMM	49
1574	0094	2105	DC	II'33,5'	LSR ABS L	4A
1575	0096	4806	DC	II'72,6'	PHK	4B
1576	0098	1C02	DC	II'28,2'	JMP ABS	4C
1577	009A	1802	DC	II'24,2'	EOR ABS	4D

## The Western Design Center

1578	009C	2102	DC	I1'33,2'	LSR ABS	4E
1579	009E	1805	DC	I1'24,5'	EOR ABS L	4F
1580	00A0	0C0F	DC	I1'12,15'	BVC	50
1581	00A2	1807	DC	I1'24,7'	EOR (D),Y	51
1582	00A4	1812	DC	I1'24,18'	EOR (D)	52
1583	00A6	1817	DC	I1'24,23'	EOR (SR),Y	53
1584	00A8	56148	DC	I1'86,24'	MVN	54
1585	00AA	180A	DC	I1'24,10'	EOR D,X	55
1586	00AC	210A	DC	I1'33,10'	LSR D,X	56
1587	00AE	1808	DC	I1'24,8'	EOR (DL),Y	57
1588	00B0	1006	DC	I1'16,6'	CLI	58
1589	00B2	180E	DC	I1'24,14'	EOR	59
1590	00B4	3D15	DC	I1'61,21'	PHY	5A
1591	00B6	4B06	DC	I1'75,6'	TCD	5B
1592	00B8	1C03	DC	I1'28,3'	JMP ABSL	5C
1593	00BA	180C	DC	I1'24,12'	EOR ABS,X	5D
1594	00BC	210C	DC	I1'33,12'	LSR ABS,X	5E
1595	00BE	180D	DC	I1'24,13'	EOR ABSL,X	5F
1596	00C0	2B06	DC	I1'43,6'	RTS	60
1597	00C2	0109	DC	I1'1,9'	ADC (D, X)	61
1598	00C4	4340	DC	I1'67,16'	PER	62
1599	00C6	0116	DC	I1'1,22'	ADC SR	63
1600	00C8	3E04	DC	I1'62,4'	STZ D	64
1601	00CA	0104	DC	I1'1,4'	ADC D	65
1602	00CC	2904	DC	I1'41,4'	ROR D	66
1603	00CE	0113	DC	I1'1,19'	ADC (DL)	67
1604	00D0	2615	DC	I1'38,21'	PLA	68
1605	00D2	0101	DC	I1'1,1'	ADC	69
1606	00D4	2905	DC	I1'41,5'	ROR ABSL	6A
1607	00D6	5506	DC	I1'85,6'	RTL	6B
1608	00D8	1C11	DC	I1'28,17'	JMP (A)	6C
1609	00DA	0102	DC	I1'1,2'	ADC ABS	6D
1610	00DC	2902	DC	I1'41,2'	ROR ABS	6E
1611	00DE	0103	DC	I1'1,3'	ADC ABSL	6F
1612	00E0	0D0F	DC	I1'13,15'	BVS	70
1613	00E2	0108	DC	I1'1,8'	ADC (D),Y	71
1614	00E4	0112	DC	I1'1,18'	ADC (D)	72
1615	00E6	0117	DC	I1'1,23'	ADC (SR),Y	73
1616	00E8	3E0A	DC	I1'62,10'	STZ D,X	74
1617	00EA	010A	DC	I1'1,10'	ADC D,X	75
1618	00EC	290A	DC	I1'41,10'	ROR D,X	76
1619	00EE	0108	DC	I1'1,8'	ADC (DL),Y	77
1620	00F0	2F06	DC	I1'47,6'	SEI	78
1621	00F2	010E	DC	I1'1,14'	ADC ABS,Y	79
1622	00F4	3B15	DC	I1'59,21'	PLY	7A
1623	00F6	4C06	DC	I1'76,6'	TDC	7B
1624	00F8	1C14	DC	I1'28,20'	JMP (A, X)	7C
1625	00FA	010C	DC	I1'1,12'	ADC ABS,X	7D
1626	00FC	290C	DC	I1'41,12'	ROR ABS,X	7E
1627	00FE	010D	DC	I1'1,13'	ADC ABSL,X	7F
1628	0100					
1629	0100		END			
1630	0000					
1631	0000		ATRIBH	START		
1632	0000	390F	DC	I1'57,15'	BRA	80
1633	0002	3009	DC	I1'48,9'	STA (D, X)	81
1634	0004	5310	DC	I1'83,16'	BRL	82
1635	0006	3016	DC	I1'48,22'	STA-,S	83
1636	0008	3204	DC	I1'50,4'	STY D	84
1637	000A	3004	DC	I1'48,4'	STA D	85
1638	000C	3104	DC	I1'49,4'	STX D	86
1639	000E	3013	DC	I1'48,19'	STA [ D ]	87
1640	0010	1706	DC	I1'23,6'	DEY	88
1641	0012	0701	DC	I1'7,1'	BIT IMM	89
1642	0014	3606	DC	I1'54,6'	TXA	8A
1643	0016	4615	DC	I1'70,21'	PHB	8B



## The Western Design Center

1644	0018	3203	DC	11'50,2'	STY ABS	8C
1645	001A	3002	DC	11'48,2'	STA ABS	8D
1646	001C	3102	DC	11'49,2'	STX ABS	8E
1647	001E	3003	DC	11'48,3'	STA ABS L	8F
1648	0020	040F	DC	11'4,15'	BC	90
1649	0022	3007	DC	11'48,7'	STA (D),Y	91
1650	0024	3012	DC	11'48,18'	STA (D)	92
1651	0026	3017	DC	11'48,23'	STA (SR),Y	93
1652	0028	320A	DC	11'50,10'	STY D,X	94
1653	002A	300A	DC	11'48,10'	STA D,X	95
1654	002C	310B	DC	11'49,11'	STX D,Y	96
1655	002E	3008	DC	11'48,8'	STA (DL),Y	97
1656	0030	3806	DC	11'56,6'	TYA	98
1657	0032	300E	DC	11'48,14'	STA ABS,Y	99
1658	0034	3706	DC	11'55,6'	TXS D	9A
1659	0036	4F06	DC	11'79,6'	TXY	9B
1660	0038	3E02	DC	11'62,2'	STZ ABS	9C
1661	003A	300C	DC	11'48,12'	STA ABS,X	9D
1662	003C	3E0C	DC	11'62,12'	STZ ABS,X	9E
1663	003E	300D	DC	11'48,13'	STA ABSL,X	9F
1664	0040	2001	DC	11'32,1'	LDY IMM	A0
1665	0042	1E09	DC	11'30,9'	LDA (D,X)	A1
1666	0044	1F01	DC	11'31,1'	LDX IMM	A2
1667	0046	1E16	DC	11'30,22'	LDA SR	A3
1668	0048	2004	DC	11'32,4'	LDY D	A4
1669	004A	1E04	DC	11'30,4'	LDA D	A5
1670	004C	1F04	DC	11'31,4'	LDX D	A6
1671	004E	1E13	DC	11'30,19'	LDA (DL)	A7
1672	0050	3406	DC	11'52,6'	TAY	A8
1673	0052	1E01	DC	11'31,1'	LDA IMM	A9
1674	0054	3306	DC	11'51,6'	TAX	AA
1675	0056	4415	DC	11'68,21'	PLB	AB
1676	0058	2002	DC	11'32,2'	LDY ABS	AC
1677	005A	1E02	DC	11'30,2'	LDA ABS	AD
1678	005C	1F02	DC	11'31,2'	LDX ABS	AE
1679	005E	1E03	DC	11'30,3'	LDA ABS L	AF
1680	0060	050F	DC	11'5,15'	BCS	B0
1681	0062	1E07	DC	11'30,7'	LDA (D),Y	B1
1682	0064	1E12	DC	11'30,18'	LDA (D)	B2
1683	0066	1E17	DC	11'30,23'	LDA (SR),Y	B3
1684	0068	200A	DC	11'32,10'	LDY D,X	B4
1685	006A	1E0A	DC	11'30,10'	LDA D,X	B5
1686	006C	1E0B	DC	11'30,11'	LDX D,Y	B6
1687	006E	1E08	DC	11'30,8'	LDA (DL),Y	B7
1688	0070	1106	DC	11'17,6'	CLV	B8
1689	0072	1E0E	DC	11'30,14'	LDA ABS,Y	B9
1690	0074	3506	DC	11'53,6'	TSX	BA
1691	0076	5006	DC	11'80,6'	TYX	BB
1692	0078	200C	DC	11'32,12'	LDY ABS,X	BC
1693	007A	1E0C	DC	11'30,12'	LDA ABS,X	BD
1694	007C	1F0E	DC	11'31,14'	LDX ABS,Y	BE
1695	007E	1E0D	DC	11'30,13'	LDA ABSL,X	BF
1696	0080	1401	DC	11'30,13'	CPY	C0
1697	0082	1209	DC	11'18,9'	CMP (D,X)	C1
1698	0084	4901	DC	11'73,1'	REP	C2
1699	0086	1216	DC	11'18,22'	CMP	C3
1700	0088	1404	DC	11'20,4'	CPY D	C4
1701	008A	1204	DC	11'18,4'	CMP D	C5
1702	008C	1504	DC	11'21,4'	DEC D	C6
1703	008E	1213	DC	11'18,19'	CMP (DL)	C7
1704	0090	1B06	DC	11'27,6'	INY	C8
1705	0092	1201	DC	11'18,1'	CMP IMM	C9
1706	0094	1606	DC	11'22,6'	DEX	CA
1707	0096	5906	DC	11'89,6'	WAI	CB
1708	0098	1402	DC	11'20,2'	CPY ABS	CC
1709	009A	1202	DC	11'18,2'	CMP ABS	CD
1710	009C	1502	DC	11'21,2'	DEC ABS	CE
1711	009E	1203	DC	11'18,3'	CMP ABSL	CF

## The Western Design Center

1712	00A0	090F	DC	I1'9,15'	BNE	D0
1713	00A2	1207	DC	I1'18,7'	CMP (D0,Y	D1
1714	00A4	1212	DC	I1'18,18'	CMP (D)	D2
1715	00A6	1217	DC	I1'18,23'	CMP	D3
1716	00A8	4204	DC	I1'66,4'	PEI D	D4
1717	00AA	120A	DC	I1'18,10'	CMP D,X	D5
1718	00AC	150A	DC	I1'21,10'	DEC D,X	D6
1719	00AE	1208	DC	I1'18,8'	CMP (DL),Y	D7
1720	00B0	0F06	DC	I1'15,6'	CLD	D8
1721	00B2	120E	DC	I1'18,14'	CMP ABS,Y	D9
1722	00B4	3C15	DC	I1'60,21'	PHX	DA
1723	00B6	6406	DC	I1'100,6'	STP	DB
1724	00B8	1C11	DC	I1'28,17'	JMP (A)	DC
1725	00BA	120C	DC	I1'18,12'	CMP ABS,X	DD
1726	00BC	150C	DC	I1'21,12'	DEC ABS,X	DE
1727	00BE	120D	DC	I1'18,13'	CMP ABSL,X	DF
1728	00C0	1301	DC	I1'19,1'	CPX IMM	E0
1729	00C2	2C09	DC	I1'44,9'	SBC (D,X)	E1
1730	00C4	4A01	DC	I1'74,1'	SEP IMM	E2
1731	00C6	2C16	DC	I1'44,22'	SBC SR	E3
1732	00C8	1F04	DC	I1'31,4'	LDX D	E4
1733	00CA	2C04	DC	I1'44,4'	SBC D	E5
1734	00CC	1904	DC	I1'25,4'	INC D	E6
1735	00CE	2C13	DC	I1'44,19'	SBD (DL)	E7
1736	00D0	1A06	DC	I1'26,6'	INX D	E8
1737	00D2	2C01	DC	I1'44,1'	SBC IMM	E9
1738	00D4	2206	DC	I1'34,6'	NOP	EA
1739	00D6	5106	DC	I1'81,6'	XBA	EB
1740	00D8	1302	DC	I1'19,2'	CPX ABS	EC
1741	00DA	2C02	DC	I1'44,2'	SBC ABS	ED
1742	00DC	1902	DC	I1'25,2'	INC ABS	EE
1743	00DE	2C03	DC	I1'44,3'	SBC ABSL	EF
1744	00E0	060F	DC	I1'6,15'	BEQ	F0
1745	00E2	2C07	DC	I1'44,7'	SBC (D),Y	F1
1746	00E4	2C12	DC	I1'44,18'	SBC (D)	F2
1747	00E6	2C17	DC	I1'44,23'	SBC (SR),Y	F3
1748	00E8	4102	DC	I1'65,2'	PEA	F4
1749	00EA	2C0A	DC	I1'44,10'	SBC D,X	F5
1750	00EC	190A	DC	I1'25,10'	INC D,X	F6
1751	00EE	2C08	DC	I1'44,8'	SBC (DL),Y	F7
1752	00F0	2E06	DC	I1'46,6'	SED	F8
1753	00F2	2C0E	DC	I1'44,14'	SBC ABS,Y	F9
1754	00F4	3A15	DC	I1'58,21'	PLX	FA
1755	00F6	5206	DC	I1'82,6'	XCE	FB
1756	00F8	1D14	DC	I1'29,20'	JSR (A,X)	FC
1757	00FA	2C0C	DC	I1'44,12'	SBC ABS,X	FD
1758	00FC	190C	DC	I1'25,12'	INC ABS,X	FE
1759	00FE	2C0D	DC	I1'44,13'	SBC ABSL,X	FF
1760	0100		END			

### Global Symbols

ADDRMODE	00009C	AREG	00008F	AREGH	000090	BRKN	00FFE6
C	000001	CODE	000087	CR	00008D	DBREG	000095
DIRREG	000093	DIRREGH	000094	DPAGE	000300	EBIT	000097
M	000020	MNX	00009D	NCODE	000083	OPCREG	000084
OPCREGB	000086	OPCREGH	000085	OPLN	00009F	OPRNDB	00008A
OPRNDH	000089	OPRNDL	000088	PCREG	000080	PCREGB	000082
PCREGH	000081	PREG	000096	STACK	000091	STACKH	000092
TEMP	000099	TEMPB	00009B	TEMPH	00009A	USBRKVV	003F0
X	000010	XREG	00008B	XREGH	00008C	YREG	00008D
YREGH	00008E						

1760 source lines  
0 macros expanded  
0 lines generated  
0 page faults

## The Western Design Center

Link Editor 4.0

00008000	00000037	Code:	MAIN
00008037	000000CF	Code:	EBRKIN
00008106	00000048	Code:	FLIST
0000814E	00000120	Code:	FRMOPRND
0000826E	00000019	Code:	POB
00008287	0000002F	Code:	STEP
00008286	00000026	Code:	PUTHEX
000082DC	0000005A	Code:	CLRLN
000088336	0000005D	Code:	UPDATE
00008393	0000001A	Code:	PRINTLN
000083AD	00000043	Code:	TRACE
000083FO	0000003E	Code:	CHKSPCL
0000842E	00000069	Code:	SBRK
00008497	0000004E	Code:	DUMPREGS
000084E5	00000026	Code:	PUTREG8
000085OB	0000001C	Code:	SPJMP
00008527	00000005	Code:	PMASK
0000852C	00000017	Code:	SCODES
00008543	00000114	Data:	MN
00008657	00000032	Data:	MODES
00008689	00000018	Code:	LENS
000086A1	00000100	Data:	ATRIBL
000087A1	00000100	Code:	ATRIBH

Global symbol table:

ADDRMODE	0000009C	00	AREG	0000008F	00	AREGH	00000090	00
ATRIBH	000087A1	00	ATRIBL	000086A1	03	BRKN	0000FFE6	00
C	00000001	00	CHKSPCL	00008DF0	00	CLRLN	000082DC	00
CODE	00000087	00	CR	0000008D	00	DBREG	00000095	00
DIRREG	00000093	00	DIRREGH	00000094	00	DOBRANCH	0000841B	00
DPAGE	00000300	00	DUMPREGS	00008497	00	EBIT	00000097	00
EBRXIN	00008037	00	FABS	0000816B	00	FABSIND	000081F5	00
FABSINXIND	00008224	00	FABSL	0000816E	00	FABSLX	000081C1	00
FABSX	000081BB	00	FABSY	000081C7	00	FACC	00008174	00
FBLOCK	00008526	00	FDIR	00008171	00	FDIRINXX	000081A2	00
FDIRINXY	000081A8	00	FIMM	00008159	00	FIMP	0000817A	00
FIND	00008204	00	FINDINX	0000817B	00	FINDINXL	0000818A	00
FINDL	00008214	00	FINX	000081AE	00	FINXIND	00008190	00
FINY	0000817E	00	FLIST	00008106	00	FPCR	000081CD	00
FPCRL	000081E4	00	FRMOPRND	0000814E	00	FSRINDINX	00008244	00
FSTACK	00008233	00	FSTACKREL	00008234	00	GO	000080C4	00
LENS	00008689	00	LINE	000082EE	00	LIST	00008003	00
M	00000020	00	MAIN	00008000	00	MN	00008543	01
MNX	0000009D	00	MODES	00008657	02	MOVE	0000814A	00
NBRKIN	00008047	00	NCODE	00000083	00	OPCREG	00000084	00
OPCREGB	00000086	00	OPCREGH	00000085	00	OPLN	0000009F	00

# 16) Chapter Sixteen

## Design and Debugging

Design and debugging stand on either side of the central coding phase of the development cycle. Good techniques for both are as important as skill in actual coding. This chapter provides a checklist of some commonly encountered bugs – ones you should immediately suspect – as well as some words of advice about program design and good coding practice, which may help you avoid some of the bugs to begin with.

### Debugging Checklist

Program bugs fall into two categories: those specific to the particular processor you're writing assembly code for, and those that are generic problems which can crop up in any assembly program for almost any processor. This chapter will primarily consider bugs specific to the 65x processors, but will also discuss some generic bugs as they specifically apply in 65x assembly programs.

You may want to put a checkmark beside the bugs listed here each time you find them in your programs, giving you a personalized checklist of problems to look for. You may also want to add to the list other bugs that you write frequently.

### *Decimal Flag*

Seldom does the **d** decimal flag get miss set, but when it does, arithmetic results may seem to inexplicably go south. This can be the result of a typo, attempting to execute data, or some other execution error. Or it can result from coding errors in which the decimal flag is set to enable decimal arithmetic, then never reset. If branching occurs before the decimal flag is reset, be sure all paths ultimately result in the flag being cleared. Branching while in decimal mode is almost as dangerous as branching after temporarily pushing a value onto the stack; equal care must be taken to clear **d** and clean the stack.

This bug may be doubly hard to find on the 6502, which does not clear **d** on interrupt or, worse, on reset. An instruction inadvertently or mistakenly executed which sets **d** (only **SED**, **RTI**, or **PLP** have the capability on the 6502) would require you to specifically reclear the decimal flag or to power off and power back on again. As a result, it is always a good idea to clear the decimal flag at the beginning of every 6502 program.

### *Adjusting Carry Prior to Add / Subtract*

If you're not used to 65x processors (and even for many programmers who are), you may tend to write an **ADC** instruction without first writing a **CLC**, or an **SBC** without first an **SEC**. After all, other processors have add and subtract instructions that do not involve the carry. But the 65x processors do not; so notice the "C" in each of the instructions each time you code them and be sure the carry has the appropriate value.

### *65x Left-to-Right Syntax*

Unlike some other processors' instructions, 65x mnemonics read from left to right, just like English: **TAX**, for example, means to transfer the **A** accumulator to the **X** index register, not the opposite.

## The Western Design Center

### *65x Branches*

There are eight 65x conditional branches, each based on one of the two states of four condition code flags. Remembering how to use them for arithmetic is necessary to code branches that work.

Keep in mind that compare instructions cannot be used for signed comparisons: they don't affect the overflow flag. Only the subtract instruction can be used to compare two signed numbers directly (except for the relationships equal and not equal).

Remember that if the **z** flag is set (one), then the result was zero; and if the zero flag is clear (zero), then the result was other than zero – the opposite of most first guesses about it.

A common code sequence is to test a value, then branch on the basis of the result of the test. A common mistake is to code an instruction between the test and the branch that also affects the very flag your branch is based on (often because an instruction you don't expect to affect the flags does indeed do so).

Note that 65x pull instructions set the negative and zero flags, unlike 68xx and 8088/8086 processors; that store instructions do *not* set any flags, unlike 68xx processors; that transfer and exchange instructions *do* set flags, unlike Motorola and Intel processors; that load instructions do set flags, unlike the 8088; and increment and decrement instructions do not affect the carry flag.

Also, in decimal mode on the 6502, the negative, overflow and zero flags are not valid.

### *6502 Jump Bug*

There's hardware bug on the 6502 that causes jump indirect, with an operand which ends in \$FF (such as \$11FF), to bomb; the new high program counter value is taken incorrectly from \$1100, not the correct \$1200.

### *Interrupt-Handling Code*

To correctly handle 65x interrupts, you should generally, at the outset, save all registers and, on the 6502 and in emulation mode, clear the decimal flag (to provide a consistent binary approach to arithmetic in the interrupt handler). Returning from the interrupt restores the status register, including the previous state of the decimal flag.

During interrupt handling, once the previous environment has been saved and the new one is solid, interrupts may be enabled.

At the end of handling interrupts, restore the registers in the correct order. **RTI** will pull the program counter and status register from the stack, finishing the return to the previous environment, except that in 65802/65816 native mode it also pulls the program bank register from the stack. This means you *must* restore the mode in which the interrupt occurred (native or emulation) before executing an **RTI**.

### *65802/65816: Emulation Versus Native Mode*

Emulation mode has been provided on the 65802 and 65816 to provide continuity with existing applications. Native mode provides the powerful sixteen-bit data handling registers. But mixing emulation and native modes requires careful attention to detail. You should deal with modes systematically.

Will you limit subroutines to be called only from a certain mode? All subroutines? You must carefully document each for which mode it expects.

You must be in emulation mode on the Apple II or other 6502-based system to use the monitor and operating system 6502 routines. Furthermore, you must put 0000 into **D** (the direct page register) before return to the monitor or operating system, because zero page addressing now addresses the direct page, but the 6502 firmware left its variables in page zero before your program switched to native mode.

Any high bytes in the index registers are lost in the switch to emulation mode.

While native mode lets you set the stack anywhere, a non-page-one stack location is lost on return to emulation mode (the high byte is thrown away, replaced by the obligatory page one high byte emulation mode). Furthermore, when setting the stack with the **TCS** instruction, only the low accumulator byte is transferred to the stack pointer in emulation mode, but in native mode, the high accumulator byte, even if it is hidden, is transferred to the high stack pointer byte.

### ***65802/65816: Eight-Bit Versus Sixteen-Bit Registers***

Almost as potentially confusing as mixing emulation and native modes is mixing eight-bit and sixteen-bit modes. Again, you should deal with modes systematically.

Will you limit subroutines to be called only from a certain mode setting? You must carefully document each for the mode it expects.

Because instructions using immediate addressing are different lengths in eight- and sixteen-bit modes, being in the wrong mode will cause the processor to grab the wrong number of operand bytes, followed by a fetch for the next opcode which will miss by one and cause it to execute, as though it were an opcode, either the last operand byte of the immediate instruction, or the first operand byte of the next instruction. Either way is sure program failure.

### ***65802/65816: The Direct Page***

Avoid inadvertently branching from code written to access one direct page code written to access another without executing an instruction to reset the direct page register to the second location first (and resetting it to the original location before returning). Remember, too, that programs run faster when the direct page register is set to a page boundary.

Pay particular attention to the peculiarities of the direct page in the emulation mode: as with the 6502 and 65C02, instructions which use direct page addressing modes will “wrap” to stay within the zero page, *but only when the direct page register is equal to zero*. Opcodes which are not found on the 6502 or 65C02 will not wrap at all, even when the direct page is equal to zero in the emulation mode.

### ***65802/65816: Stack Overruns Program or Data***

No longer limited to a single page, the native-mode stack will grow downward as far as your program pushes bytes onto it. Large programs should either retrieve every byte pushed on or reset the stack periodically (using **TCS** or **TXS**). The potential danger is when a stack grows uncontrollably until it overwrites variables, your program, or the operating system.

In this connection it is important to be aware that, although the high byte of the stack register is consistently forced to one, new 65816 opcodes executed in the emulation mode will not wrap the stack if the low byte over- or underflowed in the middle of an instruction. For example, if the stack pointer is equal to \$101, and a **JSL** is executed, the final byte of the three bytes pushed on the stack will be at \$FF, not \$1FF; but the stack pointer at the end of the instruction will point to \$1FE. However, if **JSR** (a 6502 instruction) is executed in the emulation mode with the stack pointer equal to \$100, the second of the two bytes pushed will be stored at \$1FF.

### ***65802/65816: JSR/JSL and RTS/RTL***

**RTL** pulls one more byte off the stack than **RTS**: it requires that a long jump-to-subroutine (**JSL**) or its equivalent pushed a full 24-bit return address, not just a sixteen-bit one. Equally important is that a **JSL** not be made to a subroutine ended by an **RTS**, which pulls only sixteen of the 24 bits of return address pushed.

### ***65802/65816: MVN/MVP***

**MVN** and **MVP** require two operands, usually code or data labels from which the assembler strips the bank bytes, in **sourcebank,destbank** order (opposite of object code order). Eight-bit index registers will cause these two instructions to move only zero page memory. But eight-bit accumulator mode is irrelevant to the count value; the accumulator is expanded to sixteen bits using hidden **B** accumulator as the high byte of the count. Finally, the count in the accumulator is one less than the count of bytes to be moved: five in the accumulator means six bytes will be moved.

***Return Address***

If your program removes the return address from the stack in order to use it in some fashion other than using an **RTS** or **RTL** instruction to return, remember that you must add one to the stacked value to form the true return address (an operation the return-from-subroutine instructions execute automatically).

***Inconsistent Assembler Syntax***

6502 assemblers have been wildly inconsistent in their syntax, and early 65802 assemblers have not set standard either. This book describes syntax recommended by the designers of the 65816, the Western Design Center, as implemented in the ORCA/M assembler. Others, however, do and will differ. For example, while many assemblers use the syntax of a pound sign (#) in front of a sixteen-bit immediate value to specify that the low byte be accessed, with the greater-than sign (>) being used to represent the high byte, at least one 6502 assembler uses the same two signs to mean just the opposite. Syntax for the new block move instructions will undoubtedly vary from the recommended standard in many assemblers. Beware and keep you assembler's manual handy.

**Generic Bugs: They Can Happen Anywhere**

***Uninitialized Variables***

Failing to initialize variables may be the most common bug committed by programmers. Its symptom is often a program which operates strangely only the first time it is run (after which the variable has at some point been given a suitable value which remains in memory for the program's second try), or only after running a certain other program. Sometimes the symptom appears only on computers with one brand of memory chips, and not another; they happen to power up with different initial values.

***Missing Code***

The code you wrote on paper is perfect. The problem is one or more lines that never got typed in, or were typed in wrong. The solution is to compare your original handwritten code with the typed-in version, or compare a disassembly with your original code.

More enigmatically, a line may be accidentally deleted or an opcode or operand inadvertently changed by a keypress during a subsequent edit (usually in a section of code which has just been proven to work flawlessly). Regular source backups and a program that can compare text to spot changes will often solve the problem. Or you can compare a disassembly with the previous source listing.

***Failure to Increment the Index in a Loop***

The symptoms are: everything stops, and typing at the keyboard has no effect. The problem is an endless loop – your branch out of the loop is waiting for an index to reach to some specified value, but the index is never decremented or incremented and thus never reaches the target value.

## The Western Design Center

### *Failure to Clean Up Stack*

This problem is typically found in code in which first a value is pushed, then there is a conditional branch, but all paths do not pull the value still on the stack. It may result in a return address being pulled off the stack which is not really a return address (one or more bytes of it are really previously pushed data bytes).

### *Immediate Data Versus Memory Location*

Failure to use the '#' sign to signify a constant (or whatever other syntax a particular assembler requires) will instruct the assembler to load, not the constant, but data from a memory location that it assumes the constant specifies. That is, **#VAR** means access a constant (or the address of a variable); **VAR**, on the other hand, means access its contents.

### *Initializing the Stack Pointer from a Subroutine*

It won't take much thought to realize that you can't just reset the stack pointer from within a subroutine and expect the return-from-subroutine instruction to work. The return address was pointed to by the previous stack pointer. Who knows where it is in relation to the newly set one?

## Top-Down Design and Structured Programming

It's wise to carefully consider the design of a program before beginning to write any of it. The goals of design are to minimize program errors, or **bugs**; to reduce complexity; to maximize readability; and to increase the speed and ease of coding and testing and thus the productivity of programmers.

The top-down approach to structured programming combines two major design concepts. This approach is generally recognized as the method of design which best achieves these goals, particularly when coding large programs. Top-down design suggests that programs should be broken into levels: at the top level is a statement of the goal of the program; beneath it are second-level modules, which are the main control sections of the program; the sections can be broken into their parts; and so on.

A blackjack game (twenty-one), for example, might be broken down into four second-level modules, the goals of which are to deal the cards, take and place bets on the hands dealt, respond to requests for more cards, and finally compare each player's hand with the dealer's to determine winnings. The dealing module might be broken down into two third-level modules, the goals of which are to shuffle the cards, and to deliver a card to each player (executed twice so that each player gets two cards). The shuffling module might be broken into two fourth-level modules which assign a number to each card and then create a random order to the numbers.

The makeup of each level is clear. At the top level, the makeup describes the program itself. At lower levels, the makeup describes the subprocess. At the lowest levels, the work is actually done.

A top-down design is then implemented using subroutines. The top level of the program is a very short straight-line execution routine (or loop in the case of programs that start over when they reach the end), that does nothing more than call a set of subroutines, one for each second-level module of the program. The second-level subroutines may call third-level subroutines which may call fourth-level subroutines, and so on.

Structure programming is a design concept which calls for modules to have only one entry point; jumping into the middle of a module is not permitted. (A structured approach to the problem of needing an entry point to the middle of a module is to make that portion of the module a sub-module



## The Western Design Center

with its own single entry and exit points.) A second rule is that all exits return control to the calling module; all branches (selections) are internal; no branches are permitted to code outside the module.

One of the side benefits of modular programming is the ability to reuse previously coded modules in other programs: the dealing module could be dropped into any card game program that calls for shuffling followed by the dealing of one card at a time to each player. And its shuffling sub-module could be borrowed for other card game programs which only need shuffling. This use of the modularity principle should not be confused with the top-down structured design; they are distinct but related concepts. Modular programming in itself is not the same as top-down design.

A software development team could, using top-down design, readily assign one programmer the task of coding the deck-shuffling routine, another programmer the betting module, another responsibility for the dealing routines, and a fourth with writing the code for the end-of-game comparison of hands and determination of the winner.

A new programmer trying to understand a top-down program avoids becoming mired in detail while trying to get an understanding of the structure, yet can very easily figure how to get to the degree of detail which interests him.

Finally, **debugging**, the process of finding and removing programming mistakes, is exceptionally straightforward with top-down design: on seeing that, after shuffling, one of the 52 cards seems to be missing, the programmer can go directly to the shuffling subroutines to fix the problem.

Top-down design sometimes seems like a waste of time to programmers anxious to get the bytes flying; complex programs can take days or weeks of concerted thinking to break down into the subparts which fit together most logically and efficiently. But the savings in time spent coding – and recoding – and in being able to understand, debug, and modify the program later well justify the time spent on design.

## Documentation

One of the most important elements of good programming practice is **documentation**. It is remarkable how little one can recall about the nitty-gritty details of a program written just last month (or sometimes even yesterday) – the names of the key variables, their various settings and what each means and how each interacts with other variables in various routines, and so on. “Clever” programmers, those who bend programming principles to ends never anticipated, too often find they (not to mention their co-workers) can no longer discover the meaning behind their cleverness when it comes time to debug or modify that code.

The first principle of documentation is to make the program document itself. Choose labels which are meaningful: **DELLOOP** is a much better label for the beginning of a loop which deals cards in a card game than is **LAB137**. Substitute a label for all constants: branching if there’s a 1 in some register after writing a byte to disk is, by itself, meaningless; branching because there’s a constant named **DISKFULL** in the register provides clear documentation. When your program needs to determine if an ASCII value is an upper-case letter, it’s much clearer to compare with “greater than or equal to ‘A’” than with “greater than ‘@’”. Who remembers that ‘@’ precedes ‘A’ in the ASCII chart?

Variables should be **commented** when they’re declared with a description of their purpose, their potential settings, and any default states. And if any of that information changes during the development of the program, the comment should be changed to match.

Routines should be commented when they’re written: Note the purpose of the routine, the variables or parameters which need to be set before entry into the routine, and the variables or parameters which will be passed back. If other data structures will be affected by the routine, this, too, should be commented.

Nothing is as important both to debugging of code and to continuing development of programs as documentation: self-documentation; a comment on every important line of code that explains and

## **The Western Design Center**

expands it; a comment header on every routine; and a comment on every variable. While some languages are said to be automatically “self-documenting,” no language can create documentation which is half adequate compared to what the original programmer can provide while the program is being written.

# 17) Chapter Seventeen

## The Addressing Modes

There are fourteen addressing modes available to the 6502, all of those plus two more on the 65C02, and another nine categories available on the 65802 and 65816. Each mode allows the location of the data being referenced by a given instruction to be specified in a different manner. The availability of many different addressing modes on the 65x processors is one key to their power.

The data found in operand bytes of an instruction is only one part of the effective address specification; the addressing modes, expressed using the correct address-mode syntax in the operand field of an assembly-language statement, cause the assembler to choose from among the instruction's possible opcodes to one specific to the addressing mode. Not all addressing modes are available for all instructions; but there is one unique opcode for each combination of addressing mode and operation.

The addressing mode is the determinant of the effective address for an operation – the memory address that the instruction will access for data or to transfer control within the program. For a few of the 65x addressing modes, the effective address is provided in the operand field of the instruction. But for most of them, formation of the effective address involves an address calculation, that is, the addition of two or more values. The addressing mode used with a given instruction indicates where these values are to come from and how they are to be added together to form the effective address. This effective address calculation has as many forms as there are addressing modes.

An important aspect of effective address calculation on the 65802 and 65816, to be considered in addition to the addressing modes themselves, is the state of the **x** index-register select flag and, to a lesser extent, the **m** memory/accumulator select flag, both in the status register. In a sense, the **x** flag, for example, extends the addressing mode specification part of an instruction, which uses an indexed addressing mode, by determining whether or not an eight-bit or sixteen-bit index register is to be used. For every one of the indexed addressing modes, there are two similar methods of forming an effective address, depending on the setting of the index-register select flag. Pay special attention to the status and effects of the select flags.

In the following pages are graphic and written presentations of each of the addressing modes, illustrating the effective address formation, complete with a listing of the processors on which, and the instructions to which, each addressing mode is available. A sample of the assembler syntax used to invoke each one is included as well.

The descriptions are the complete set available on the 65816. The differences between the four processors, with their various modes, are graphically noted whenever possible.

The 65816's native mode features index registers and an accumulator which may be either eight bits or sixteen, depending on the settings of two mode select flags (**x** sets the index registers to eight or sixteen bits; **m** sets the accumulator and memory to eight or sixteen).

The 65802's native mode differs in that, while the bank registers are part of effective address formation, bank values are not propagated to the bus, so long addressing modes have no bank effect. The bank accessed is always bank zero, so there is, essentially, no bank portion to the effective address generated.

The 6502 emulation mode on the 65802 and 65816 processors (**e** = 1) differs in that the stack pointer's high byte is always \$01; direct page indexed addressing always wraps around to remain in the direct page rather than crossing over into the next page (so the high direct page byte remains the high byte of all direct page addresses formed). The exception to this is that zero page stack wrapping is only enforced for 6502 and 65C02 instructions, and only when **DP** = 0 in the case of page zero wrapping. New opcodes will cause effective addresses to be generated *outside* of the zero page or the emulation mode stack page if an effective address calculation overflows the low byte.

Additionally, the index registers and the **A** accumulator are limited to eight bits. (There remains, however, a hidden eight-bit **B** accumulator, as well as a 16-bit **C** accumulator which is the concatenation of **B** and **A** but which is generally not accessible except to special instructions.)

The 65C02 and 6502 differ from 6502 emulation in that there are no bank registers whatsoever; direct page addressing is, instead, zero page addressing (\$0000 is the zero page base to which offsets and, sometimes,

**The Western Design Center**

index values are added; there is no direct page register); and there is no hidden **B** accumulator nor concatenated **C** accumulator.

The symbols in Table 17.1 are used to describe the kinds of operands that are used with the various addressing modes.

Figures 17.1 through 17.4 repeat the illustrations of the programming models for the four possible processor configurations: 6502/65C02, 65802 native mode, 65816 native mode, and 65816 emulation mode. The programming model for the native mode 65816 is used in the addressing mode figures that follow; for different processors or modes, compare the addressing mode figure with the processor-mode programming model for clarification of the operation of the addressing mode for that model.

addr	two-byte address
addr/const	two-byte value: either an address or a constant
const	one- or two-byte constant
destbk	64K bank to which string will be moved
dp	one-byte direct page offset (6502/65C02: zero page)
label	label of code in same 64K bank as instruction
long	three-byte address (includes bank byte)
nearlabel	label of code close enough to instruction to be reachable by a one-byte signed offset
sr	one-byte stack relative offset
srcebk	64K bank from which string will be moved

**Table 17-1 Operand Symbols**

**6502/65C02 Programming Model**

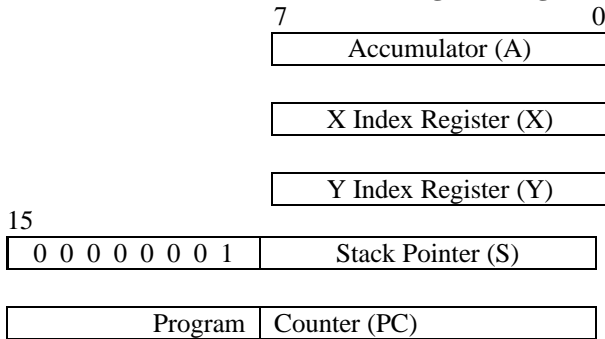

**Processor Status Register (P)**

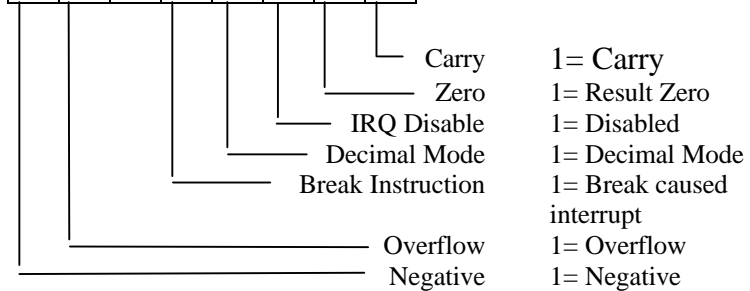

**Figure 17-1 6502/65C02 Programming Model**

The Western Design Center

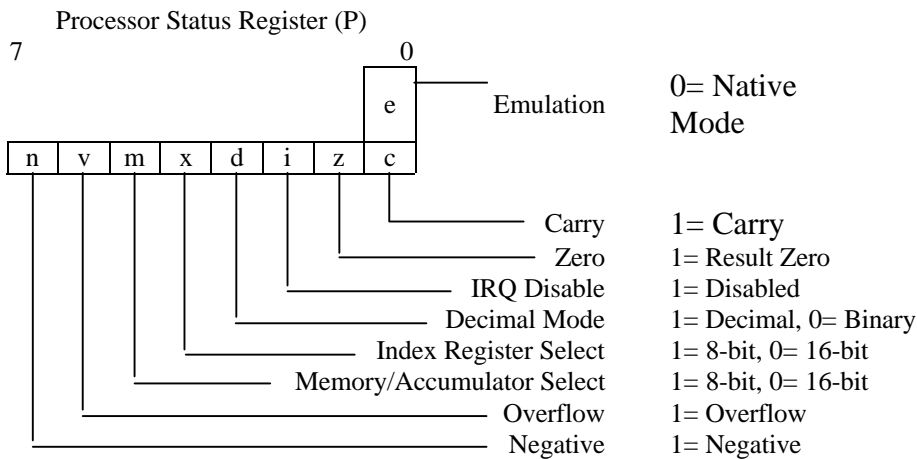
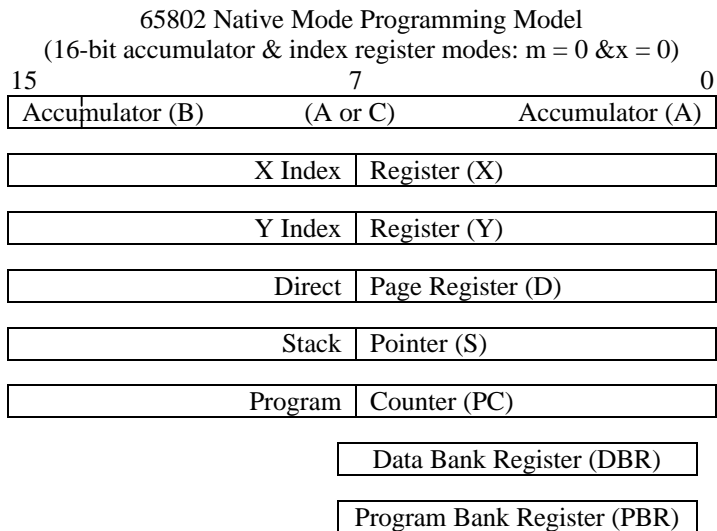

Figure 17-2. 65802 Native Mode Programming Model

65816 Native Mode Programming Model

(16-bit accumulator & index register modes: m = 0 & x = 0)

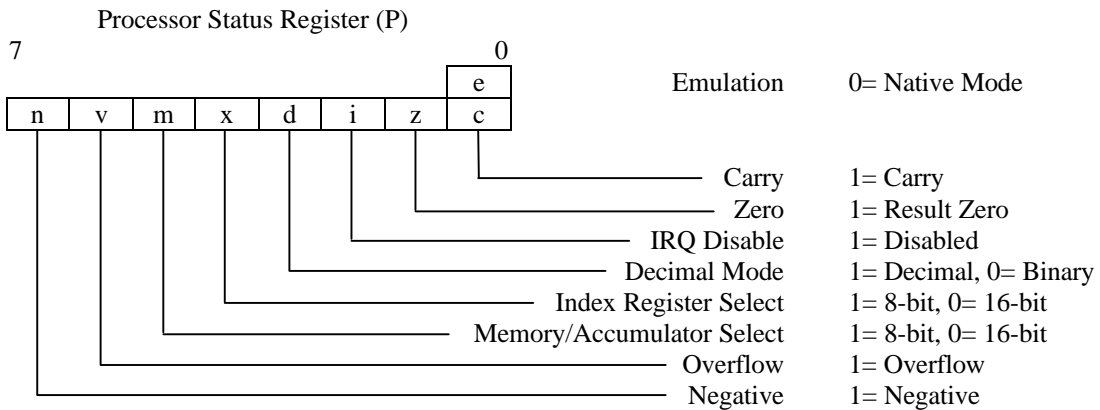
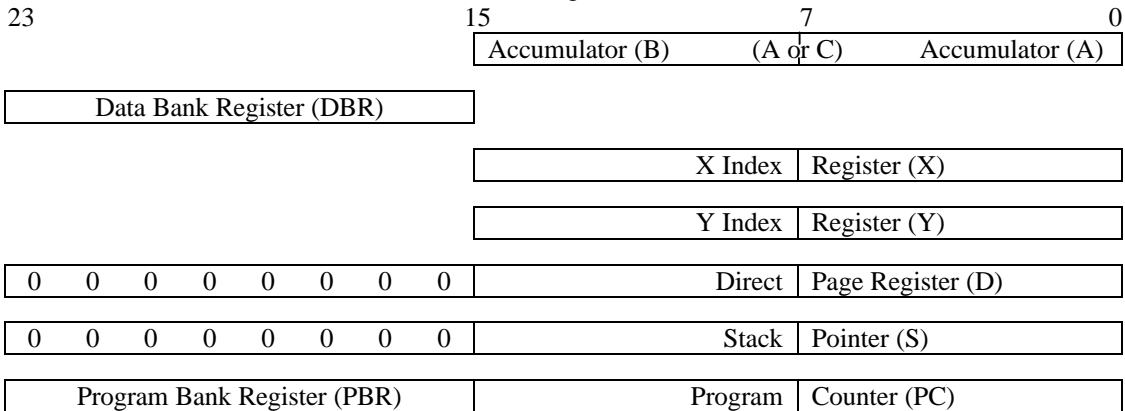
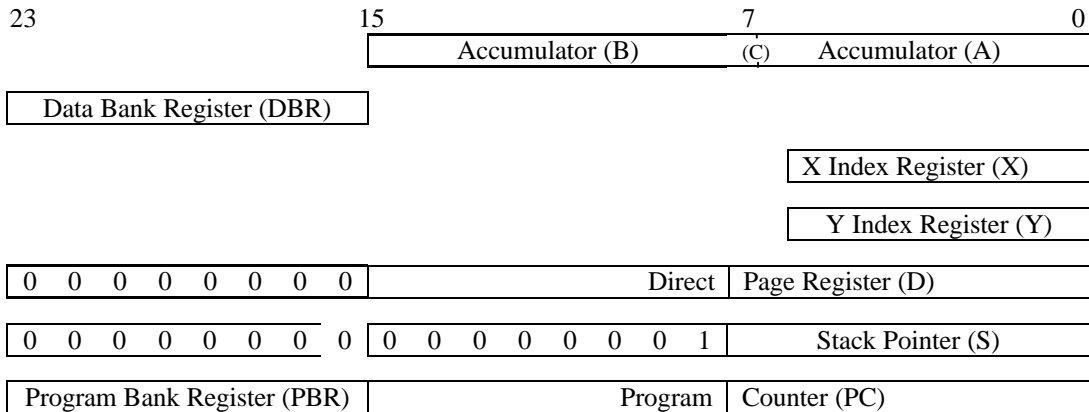

Figure 17-3 65816 Native Mode Programming Model

65816 Emulation Mode Programming Model



Processor Status Register (P)

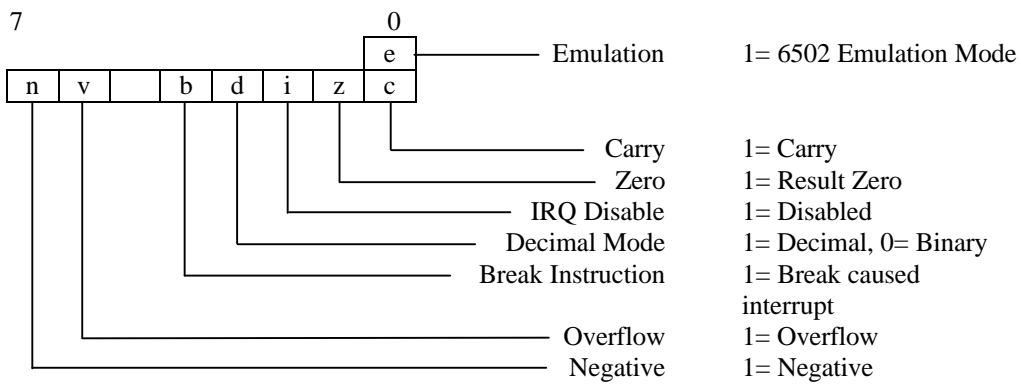

Figure 17-4 65816 Emulation Mode Programming Model

## The Western Design Center

### Absolute Addressing

#### Effective Address:

Bank: Data Bank Register (DBR) if locating data; Program Bank Register (PBR) if transferring control.

High: Second operand byte.

Low: First operand byte.

#### Sample Syntax:

LDA *addr*

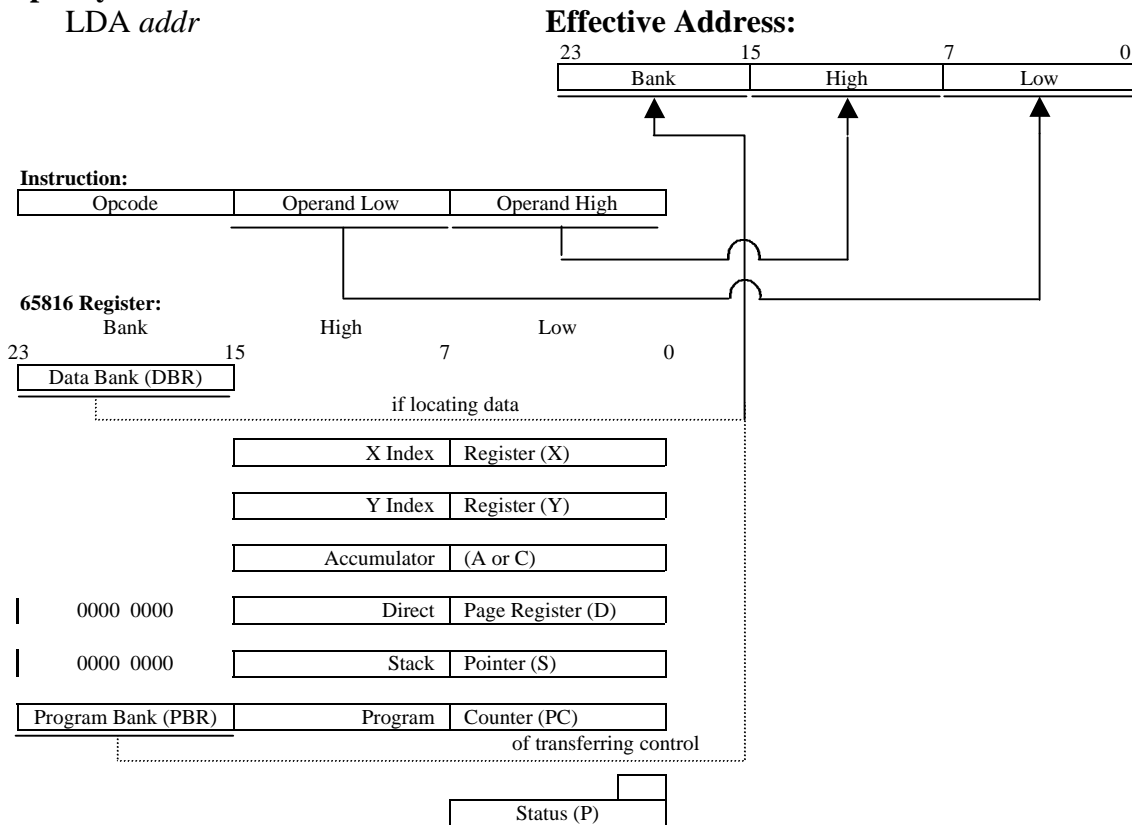

#### Instructions Using It:

##### Effective Address Locates Data

ADC	CPY	LDY	STA
AND	DEC	LSR	STX
ASL	EOR	ORA	STY
BIT	INC	ROL	STZ
CMP	LDA	ROR	TRB
CPX	LDX	SBC	TSB

##### Transfer Control to Effective Address

JMP	JSR
-----	-----

1 65C02 and 65802/65816 only.



*Absolute Indexed, X Addressing*

**Effective Address:** The Data Bank Register is concatenated with the 16-bit Operand: the 24 bit result is added to X (16 bits if 65802/65816 native mode,  $x = 0$ ; else 8).

**Sample Syntax:**

LDA *addr*, X

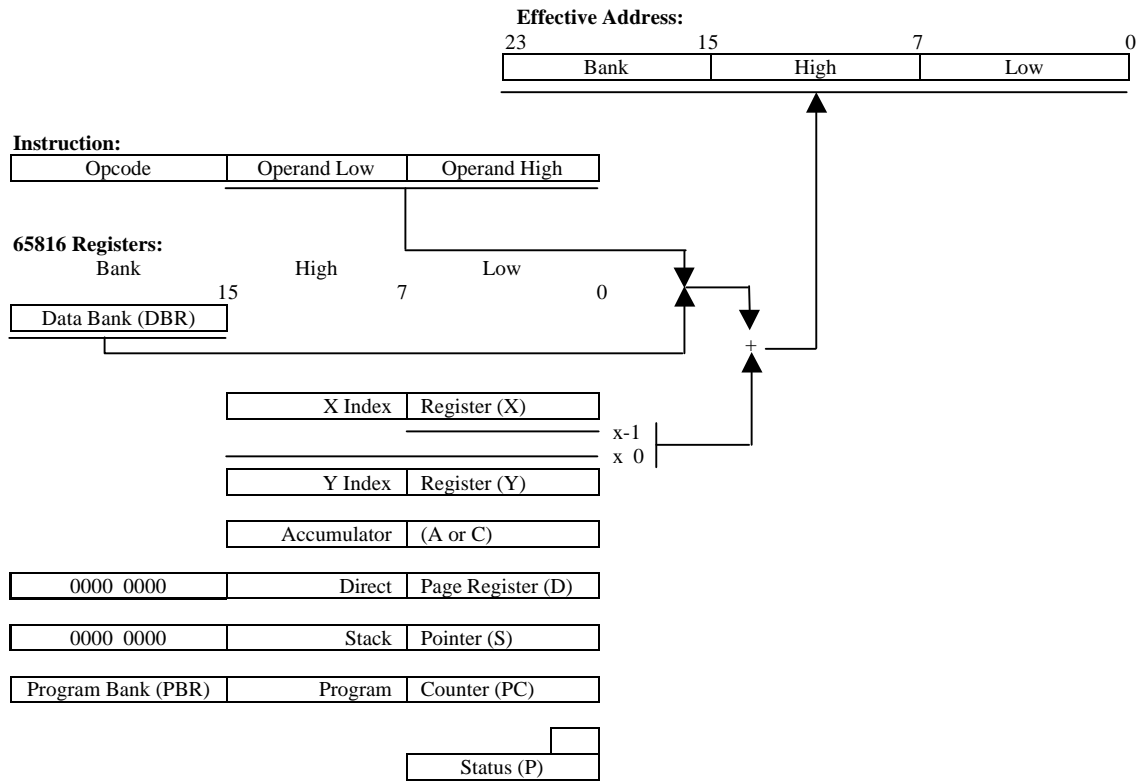

**Instructions Using It:**

Effective Address Locates Data

ADC	DEC	LSR	STA
AND	EOR	ORA	STZ
ASL	INC	ROL	
BIT	LDA	ROR	
CMP	LDY	SBC	

1 65C02 and 65802/65816 only.

**The Western Design Center**

***Absolute Indexed, Y Addressing***

**Effective Address:** The Data Bank Register is concatenated to the 16-bit Operand: the 24-bit result is added to Y (16 bits if 65802/65816 native mode, x = 0; else 8).

**Sample Syntax:**

LDA *addr*, Y

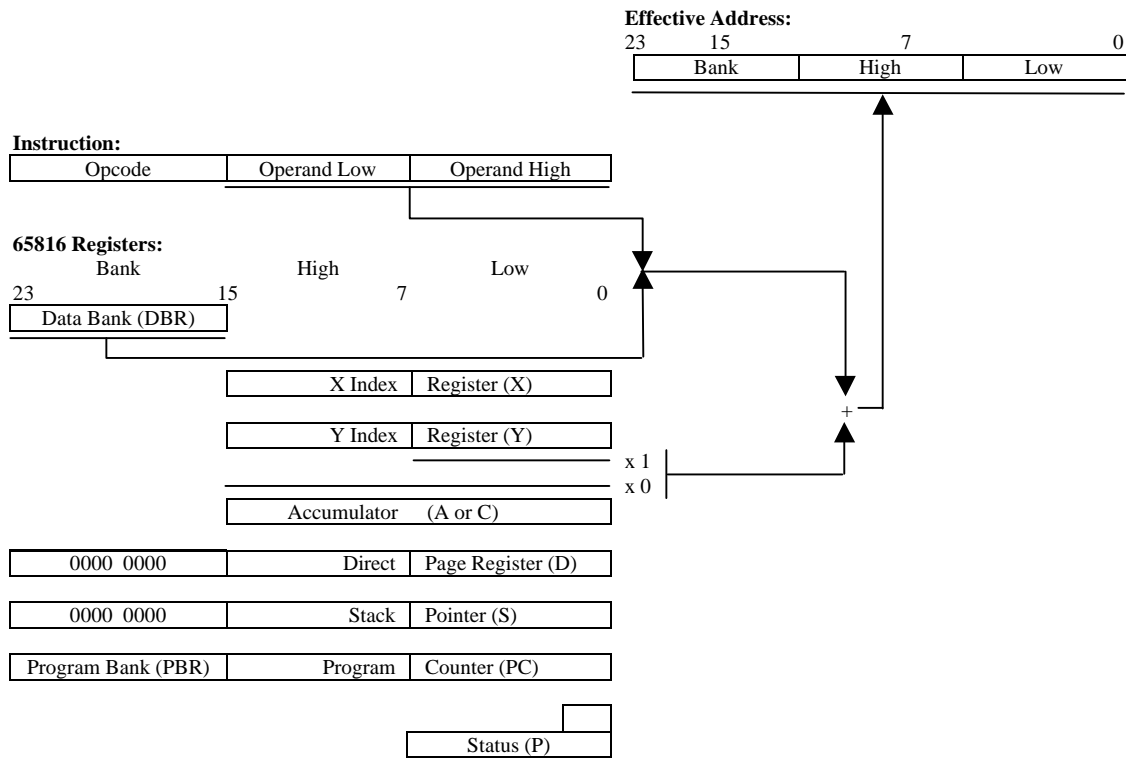

**Instructions Using It:**

Effective Address Locates Data

ADC	EOR	ORA
AND	LDA	SBC
CMP	LDX	STA

**Absolute Indexed Indirect Addressing**

**Effective Address:**

**Bank:** Program Bank Register (PBR).

**High/Low:** The Indirect Address.

**Indirect Address:** Located in the Program Bank at the sum of the Operand double byte and X (16 bits if 65802/65816 native mode, x = 0; else 8 bits).

**Sample Syntax:**

JMP (*addr*, X)

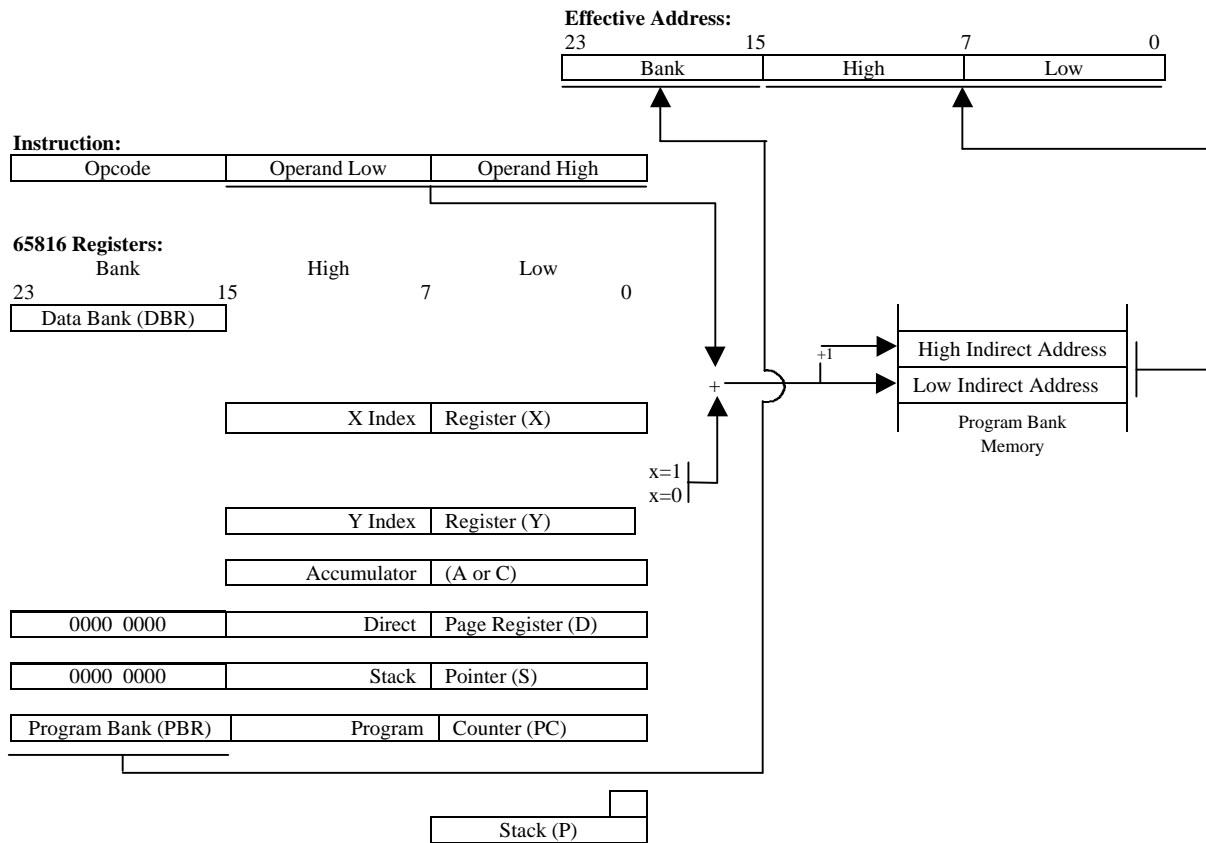

**Instructions Using It:**

Transfer Control to Effective Address

JMP<sup>1</sup> JSR<sup>2</sup>

1 65C02 and 65802/65816 only.

2 65802/65816 only.

**The Western Design Center**

***Absolute Indirect Addressing***

**Effective Address:**

Bank: Program Bank Register (PBR).

High/Low: The Indirect Address.

Indirect Address: Located in Bank Zero, at the Operand double byte.

**Sample Syntax:**

`JMP (addr)`

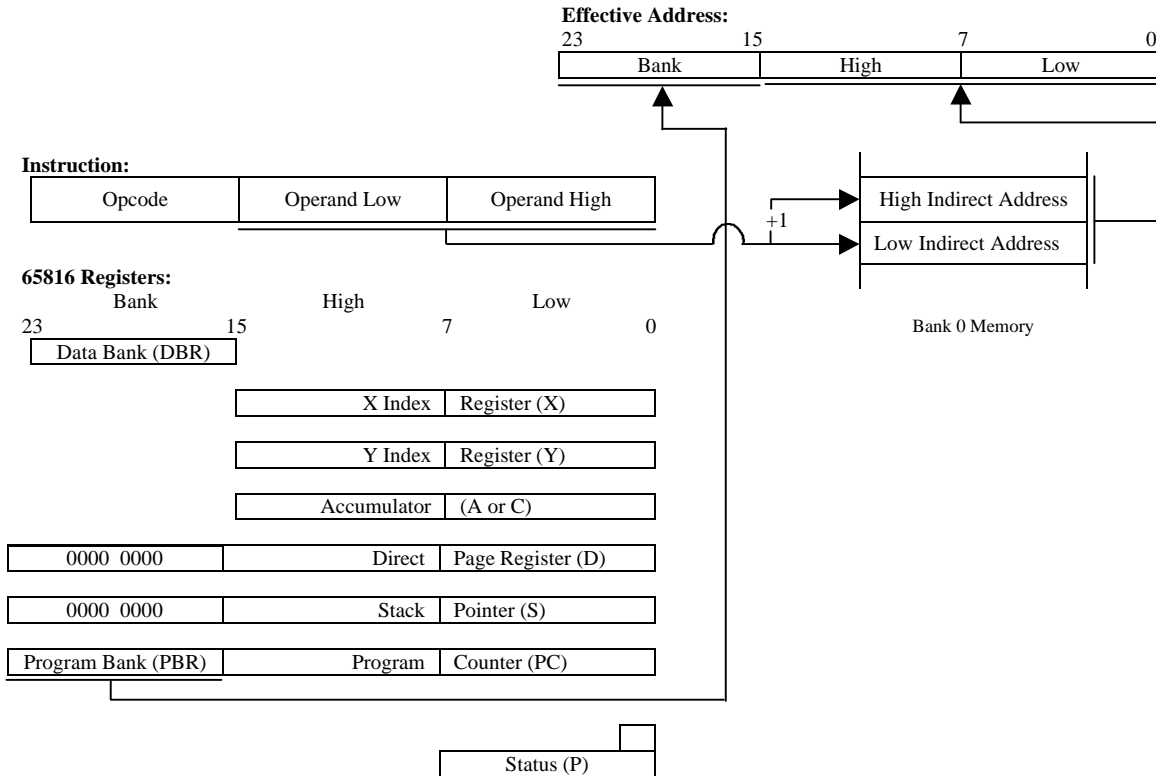

**Instructions Using It:**

Transfer Control to Effective Address  
**JMP**

**The Western Design Center**

***Absolute Indirect Long Addressing***

**Effective Address:**

Bank/High/Low: The 24-bit Indirect Address.

Indirect Address: Located in Bank Zero, at the Operand double byte.

**Sample Syntax:**

***JMP [addr]***

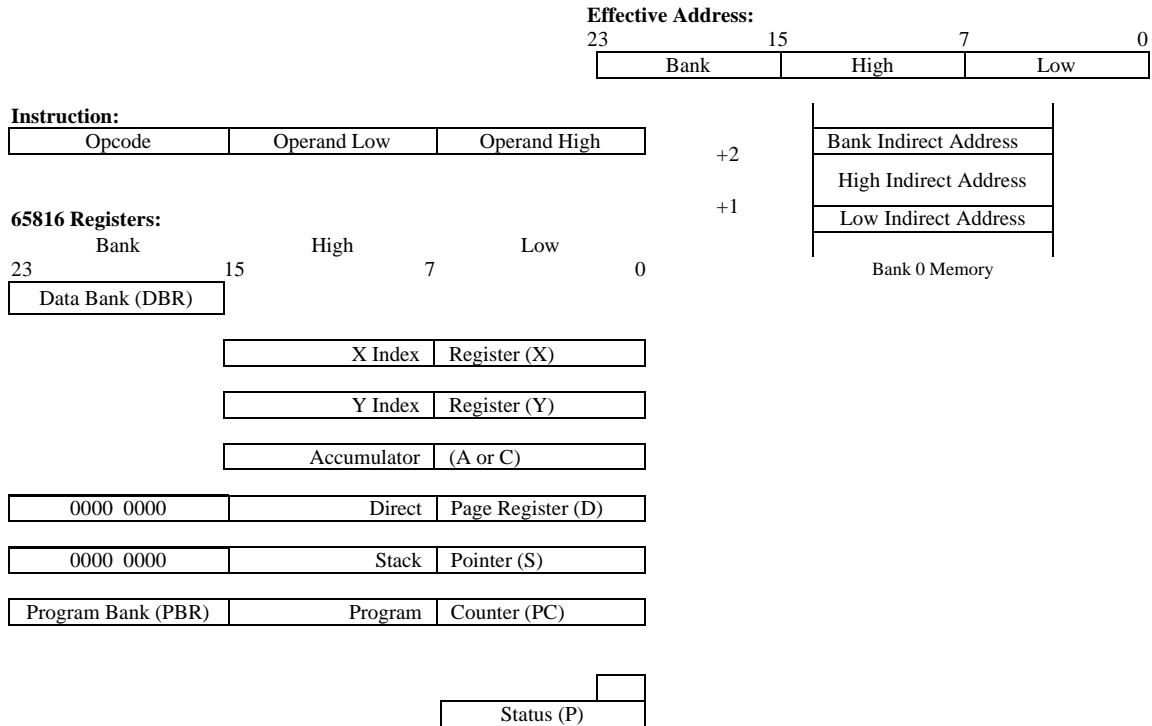

**Instructions Using It:**

Transfer Control to Effective Address  
**JMP/JML**

Note: 65802/65816 only;  
 65802: Data bank value is not propagated to the bus  
 (bank accessed is always bank 0).

**The Western Design Center**

***Absolute Long Addressing***

**Effective Address:**

- Bank: Third operand byte.
- High: Second operand byte.
- Low: First operand byte.

**Sample Syntax:**

***LDA long***

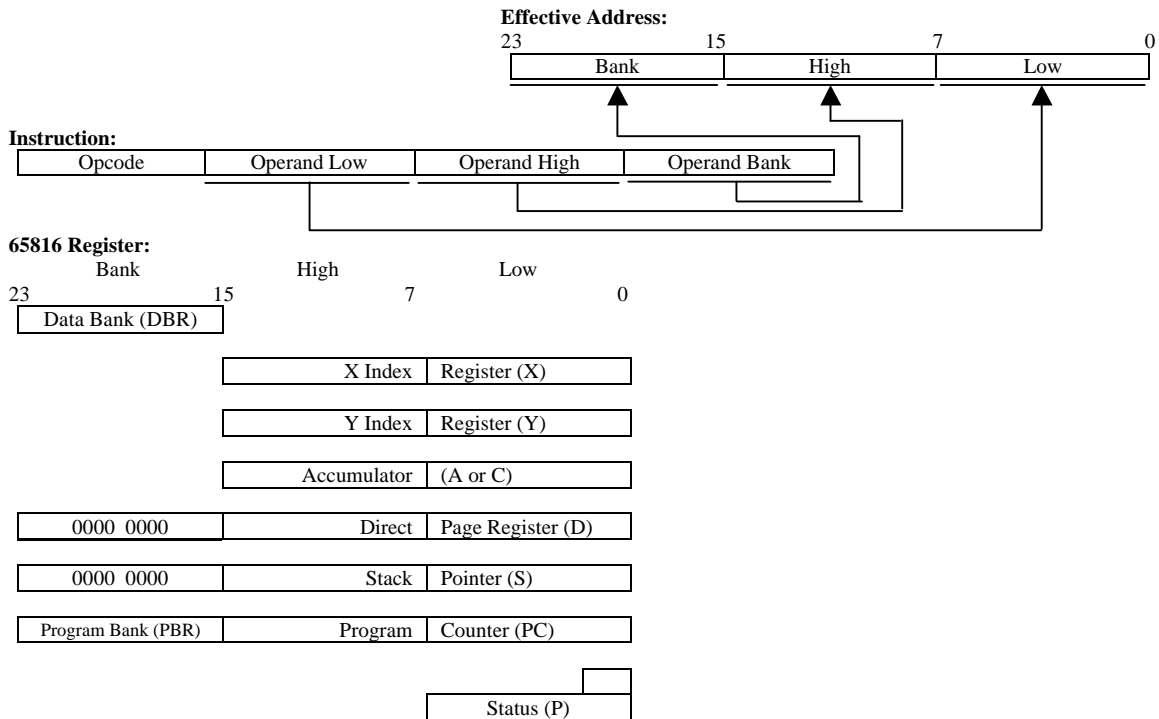

**Instruction Using It:**

Effective Address Locates Data

ADC	CMP	LDA	SBC
AND	EOR	ORA	STA

Transfer Control to Effective Address

JMP(JML)	JSR(JSL)
----------	----------

Note: All are 65802/65816 only;  
 65802: Data bank value is not propagated to the bus  
 (bank accessed is always bank 0).

**The Western Design Center**

***Absolute Long Indexed, X Addressing***

**Effective Address:** The 24-bit Operand is added to (16 bits if 65802/65816 native mode, x = 0; else 8 bits)

**Sample Syntax:**

LDA long, X

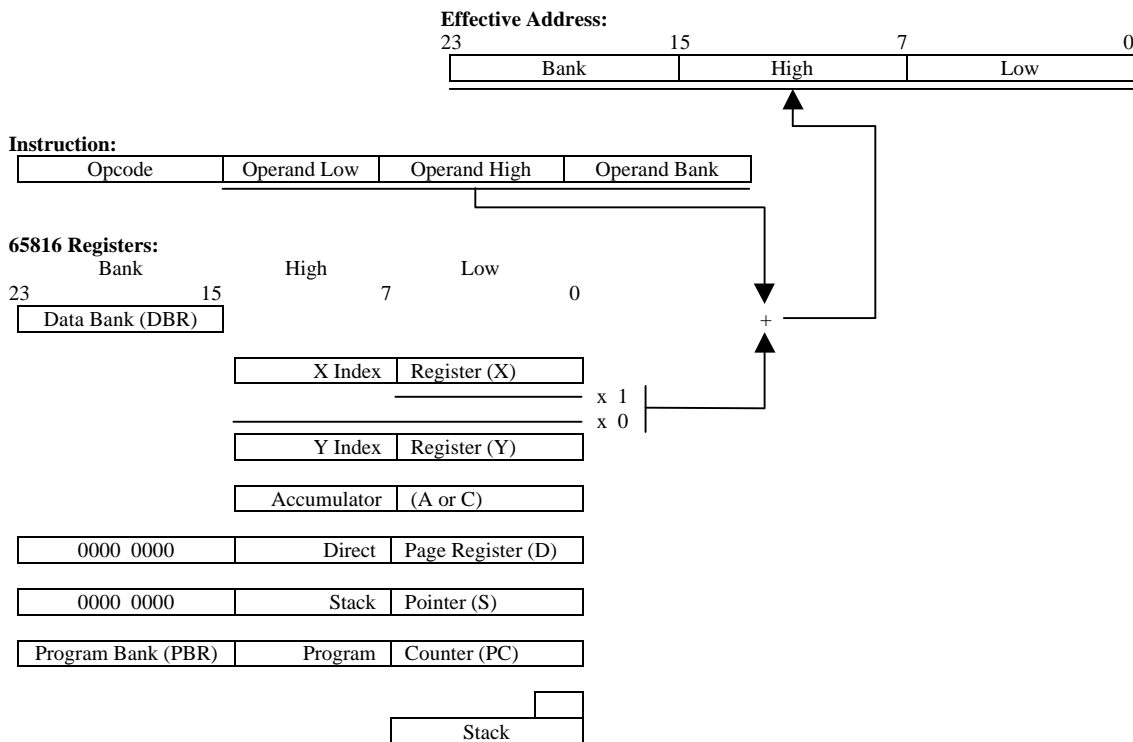

**Instructions Using It:**

Effective Address Locates Data

ADC	CMP	LDA	SBC
AND	EOR	ORA	STA

Note: All are 65802/65816 only;  
65802: Data bank value is not propagated to the bus  
(bank accessed is always bank 0).

**The Western Design Center**

**Accumulator Addressing**

**8-Bit Data (all processors):** Data: Byte in accumulator A.

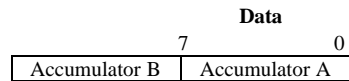

**16-Bit Data (65802/65816, native mode. 16-bit accumulator (m = 0):**

Data High: High byte in accumulator A.

Data Low: Low byte in accumulator A.

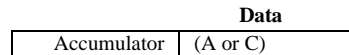

**Sample Syntax:**

ASLA

**Instruction:**

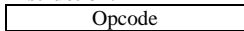

**65816 Registers:**

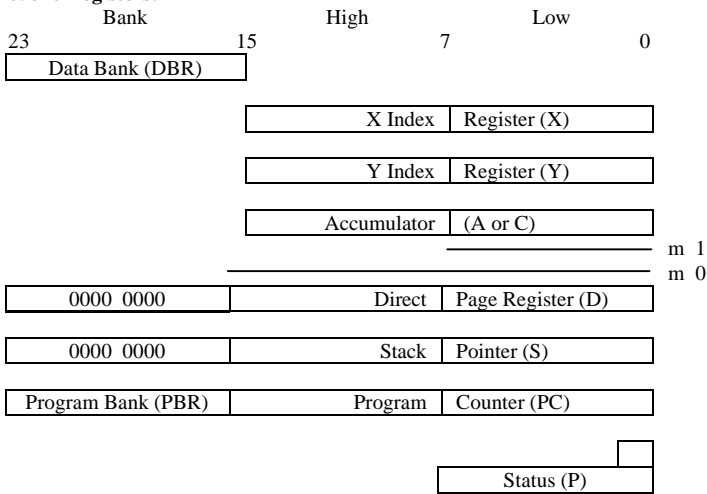

**Instructions Using It:**

ASL	INC <sup>1</sup>	ROL
DEC <sup>1</sup>	LSR	ROR

<sup>1</sup> 65C02 and 65802/65816 only.



**Block Move Addressing**

**Source Effective Address:**

Bank: Second operand byte.  
 High/Low: The 16-bit value in X; if X is only 8 bits (mode flag x = 1), the high byte is 0.

**Destination Effective Address:**

Bank: First operand byte.  
 High/Low: The 16-bit value in Y; if Y is only 8 bits (mode flag x = 1), the high byte is 0.

**Count:**

Number of bytes to be moved: 16-bit value in Accumulator C plus 1.

**Sample Syntax:**

*MVN srcebk,destbk*

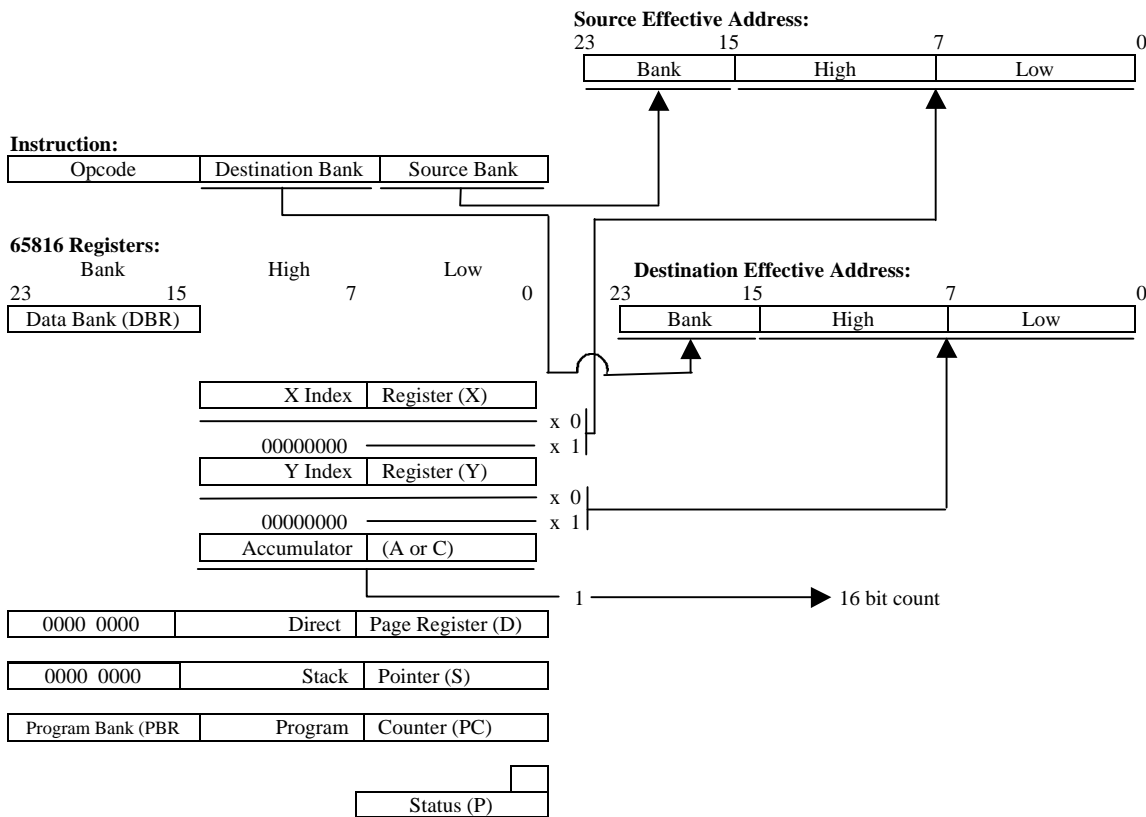

**Instructions Using It:**

Effective Address Locates Data

MVN MVP

Note: Both are 65802/65816 only;  
 65802: Data bank values are not propagated to the bus (bank accessed is always bank 0).

**The Western Design Center**

**Direct Page Addressing**

**Effective Address:**

**Bank:**

High/Low Direct Page Register plus Operand byte.

**Sample Syntax:**

LDA *dp*

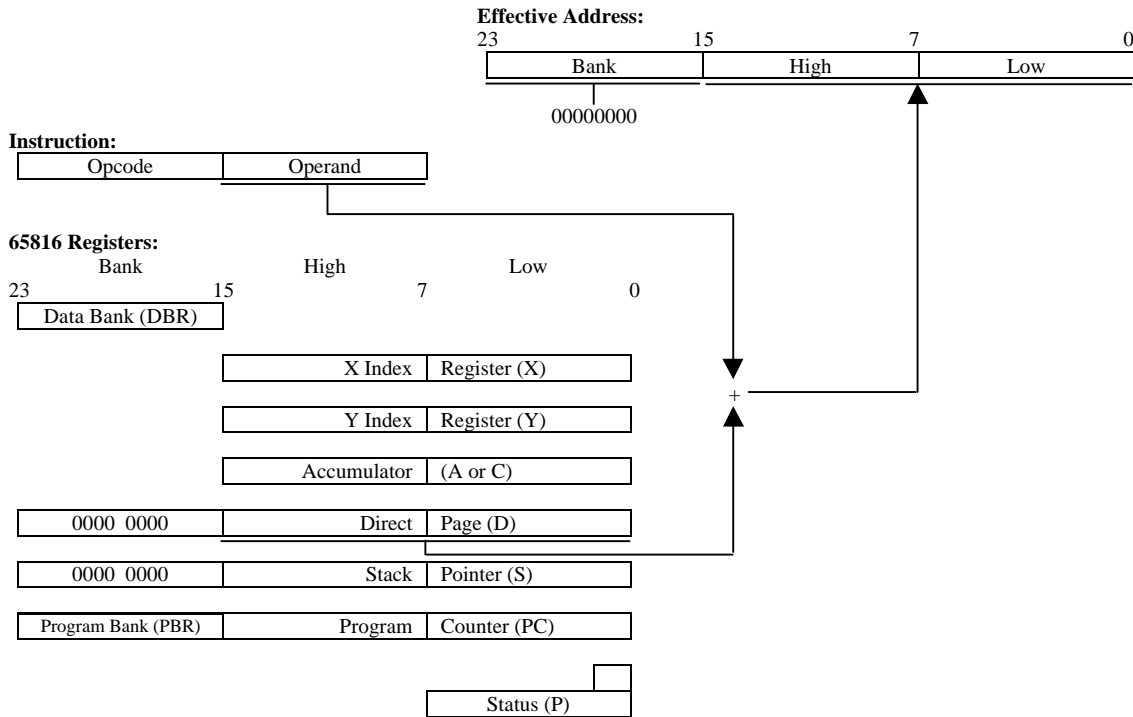

**Instructions Using It:**

Effective Address Locates Data

ADC	CPY	LDY	STA
AND	DEC	LSR	STX
ASL	EOR	ORA	STY
BIT	INC	ROL	STZ <sup>1</sup>
CMP	LDA	ROR	TRB <sup>1</sup>
CPX	LDX	SBC	TSB <sup>1</sup>

<sup>1</sup> 65C02 and 65802/65816 only.

**The Western Design Center**

**Direct Page Indexed, X Addressing**

**Effective Address:**

Bank: Zero

High/Low: Direct Page Register plus Operand byte plus X (16 bits if 65802/65816 native mode, x = 0; else 8 bits).

**Sample Syntax:**

LDA dp, X

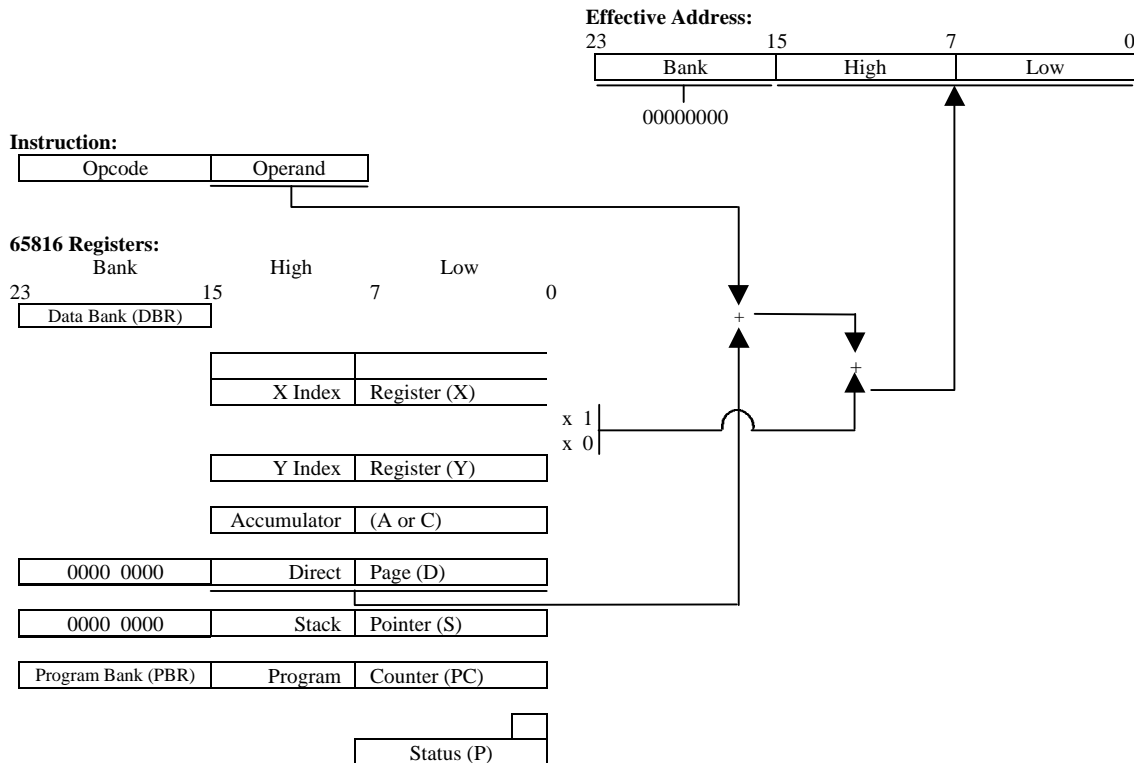

**Instruction Using It:**

Effective Address Locates Data

ADC	DEC	LSR	STA
AND	EOR	ORA	STY
ASL	INC	ROL	STZ <sup>1</sup>
BIT <sup>1</sup>	LDA	ROR	
CMP	LDY	SBC	

<sup>1</sup> 65C02 and 65802/65816 only.

**The Western Design Center**

**Direct Page Indexed, Y Addressing**

**Effective Address:**

Bank: Zero

High/Low: Direct Page Register plus Operand byte plus Y (16 bits if 65802/65816 native mode, x = 0; else 8 bits).

**Sample Syntax:**

LDA dp, Y

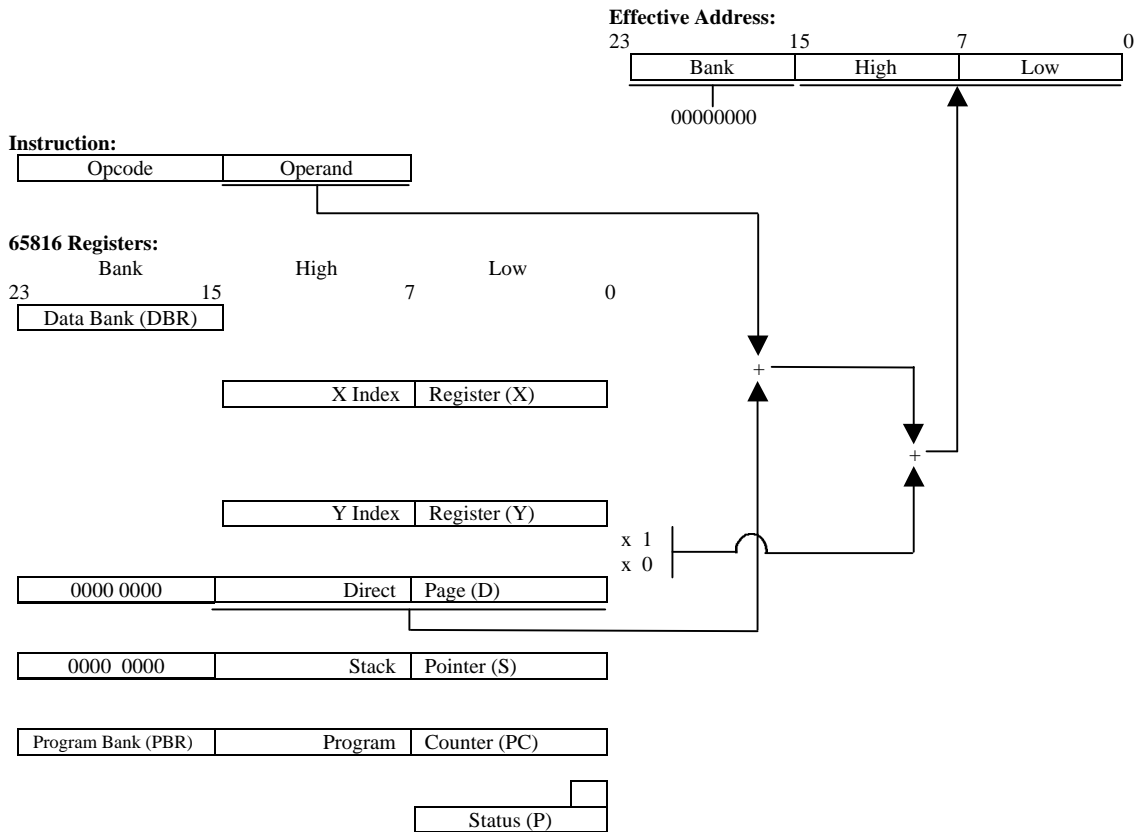

**Instruction Using It:**

Effective Address Locates Data  
LDX STX

**The Western Design Center**

***Direct Page Indexed Indirect, X Addressing***

**Effective Address:**

Bank: Data bank register.

High/Low: The indirect address.

Indirect Address: Located in the direct page at the sum of the direct page register, the operand byte, and X (16 bits if 65802/65816 native mode, x = 0; else 8), in bank 0.

**Sample Syntax:**

LDA (*dp*, X)

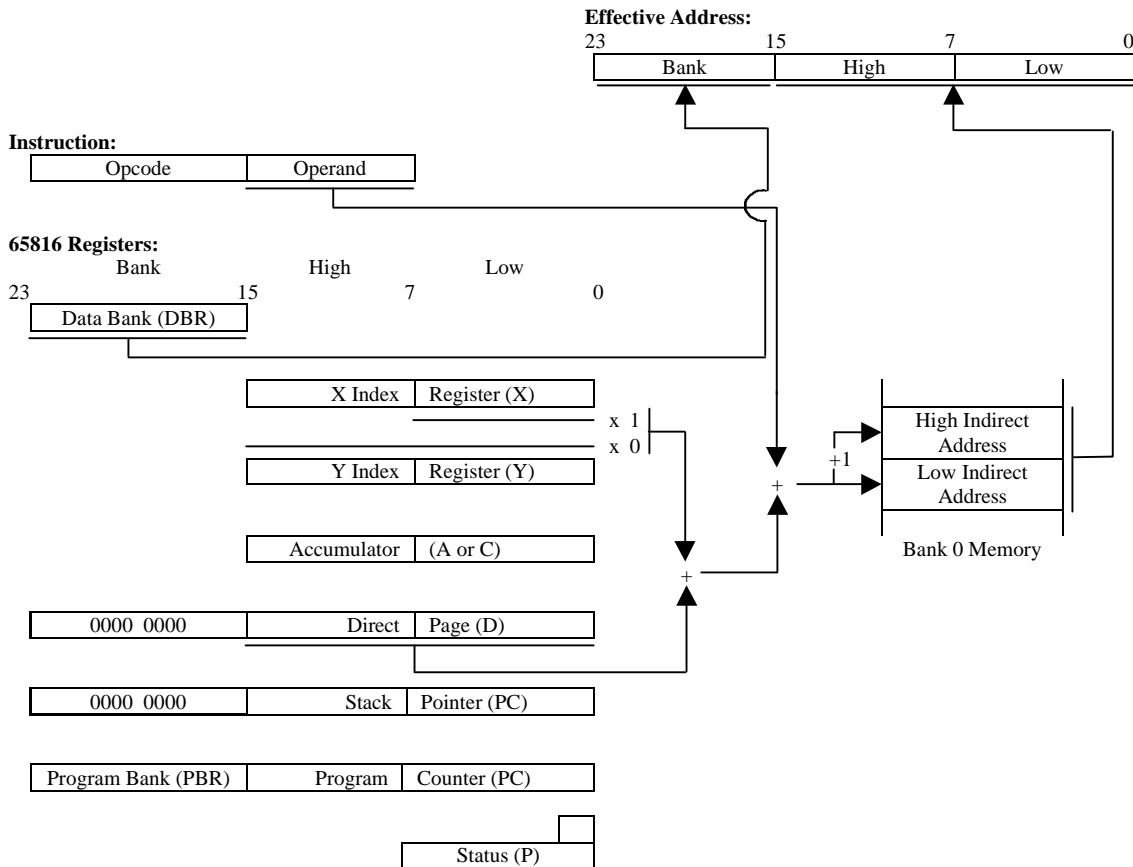

**Instructions Using It:**

Effective Address Locates Data

ADC	CMP	LDA	SBC
AND	EOR	ORA	STA

**The Western Design Center**

**Direct Page Indirect Addressing**

**Effective Address:**

Bank: Data Bank Register (DBR)  
 High/Low: The 16-bit Indirect Address  
 Indirect Address: The Operand byte plus the Direct Page Register, in Bank Zero.

**Sample Syntax:**

LDA (dp)

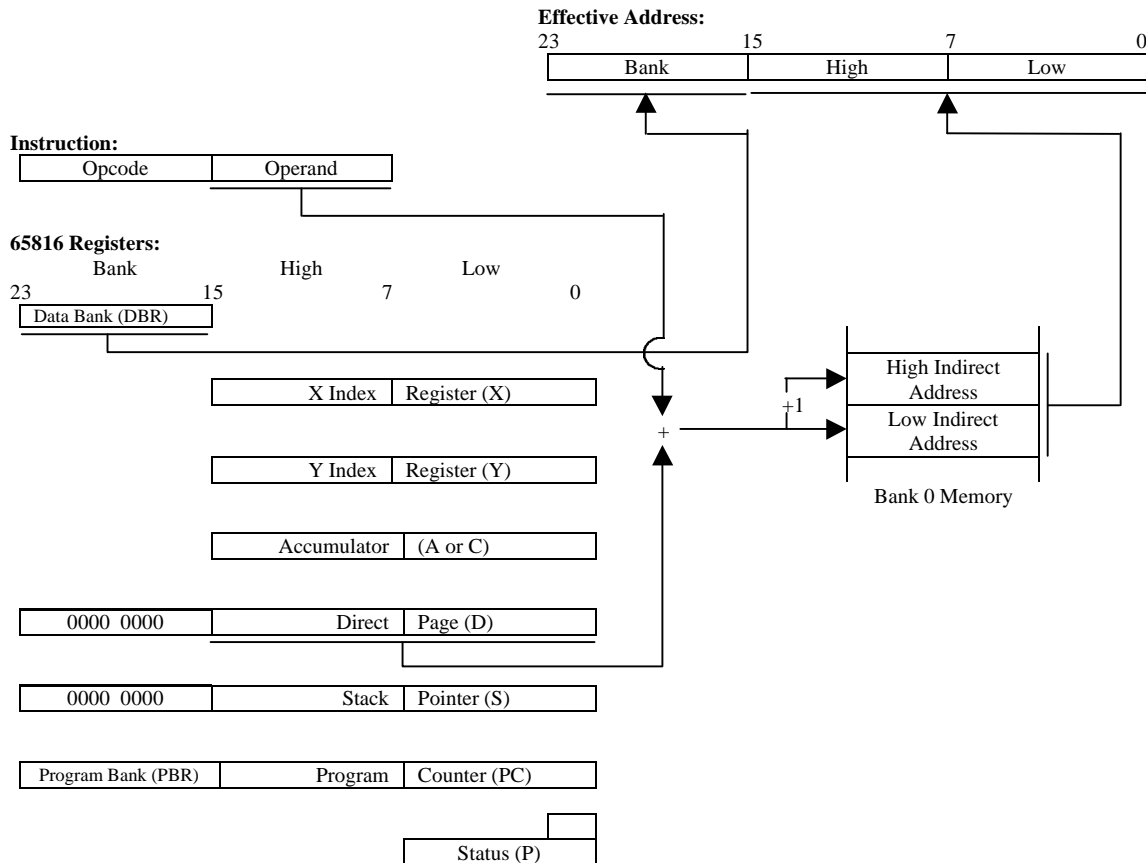

**Instructions Using It:**

Effective Address Located Data			
ADC	CMP	LDA	SBC
AND	EOR	ORA	STA

Note: All are 65C02 and 65802/65816 only.

**The Western Design Center**

***Direct Page Indirect Long Addressing***

**Effective Address:**

Bank/High/Low: The 24-bit Indirect Address.

Indirect Address: The Operand byte plus the Direct Page Register, in Bank Zero.

**Sample Syntax:**

LDA [dp]

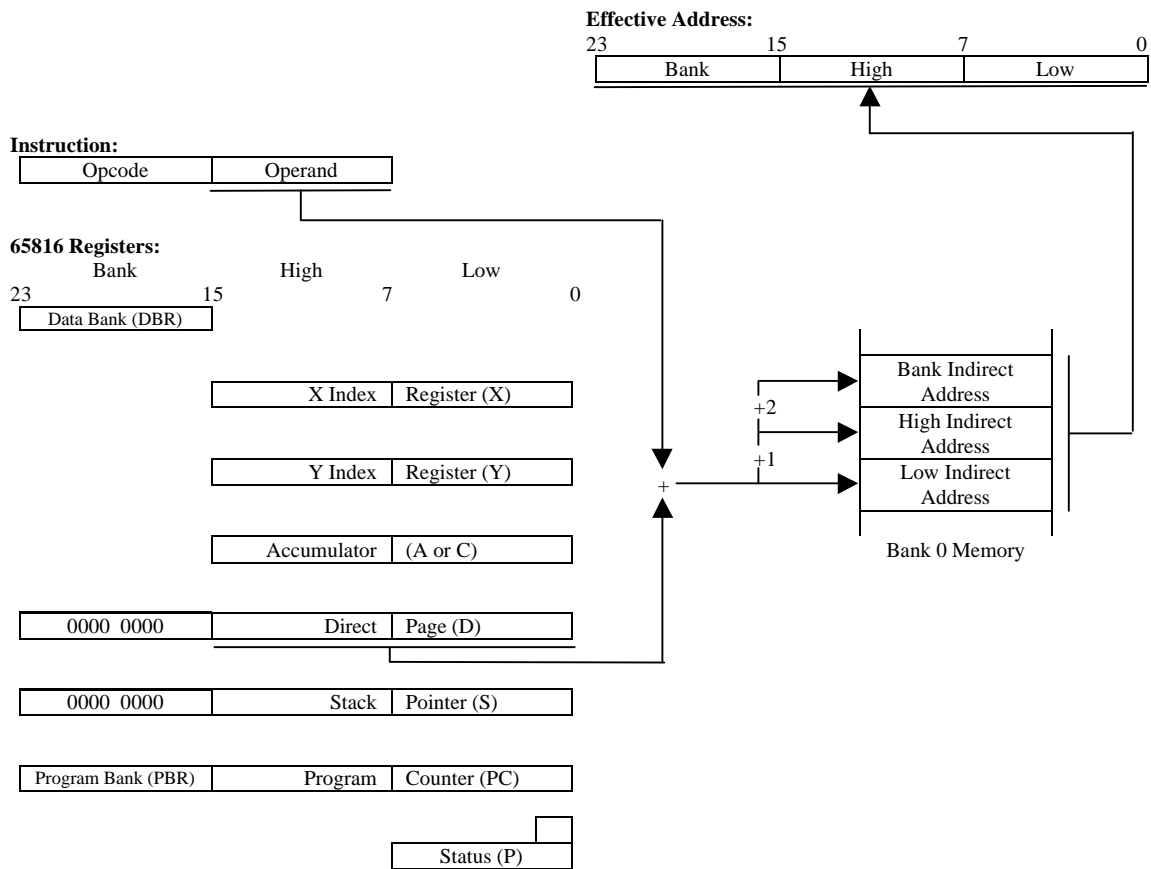

**Instruction Using It:**

Effective Address Locates Data

ADC	CMP	LDA	SBC
AND	EOR	ORA	STA

Note: All are 65802/65816 only;  
65802: Data bank value is not propagated to the bus  
(bank accessed is always bank 0).

**The Western Design Center**

**Direct Page Indirect Indexed, Y Addressing**

**Effective Address:** Found by concatenating the data bank to the double-byte indirect address, then adding Y (16 bits if 65802/65816 native mode, x = 0; else 8).

**Indirect Address:** Located in the Direct Page at the sum of the direct page register and the operand byte, in bank zero.

**Sample Syntax:**

LDA (dp), Y

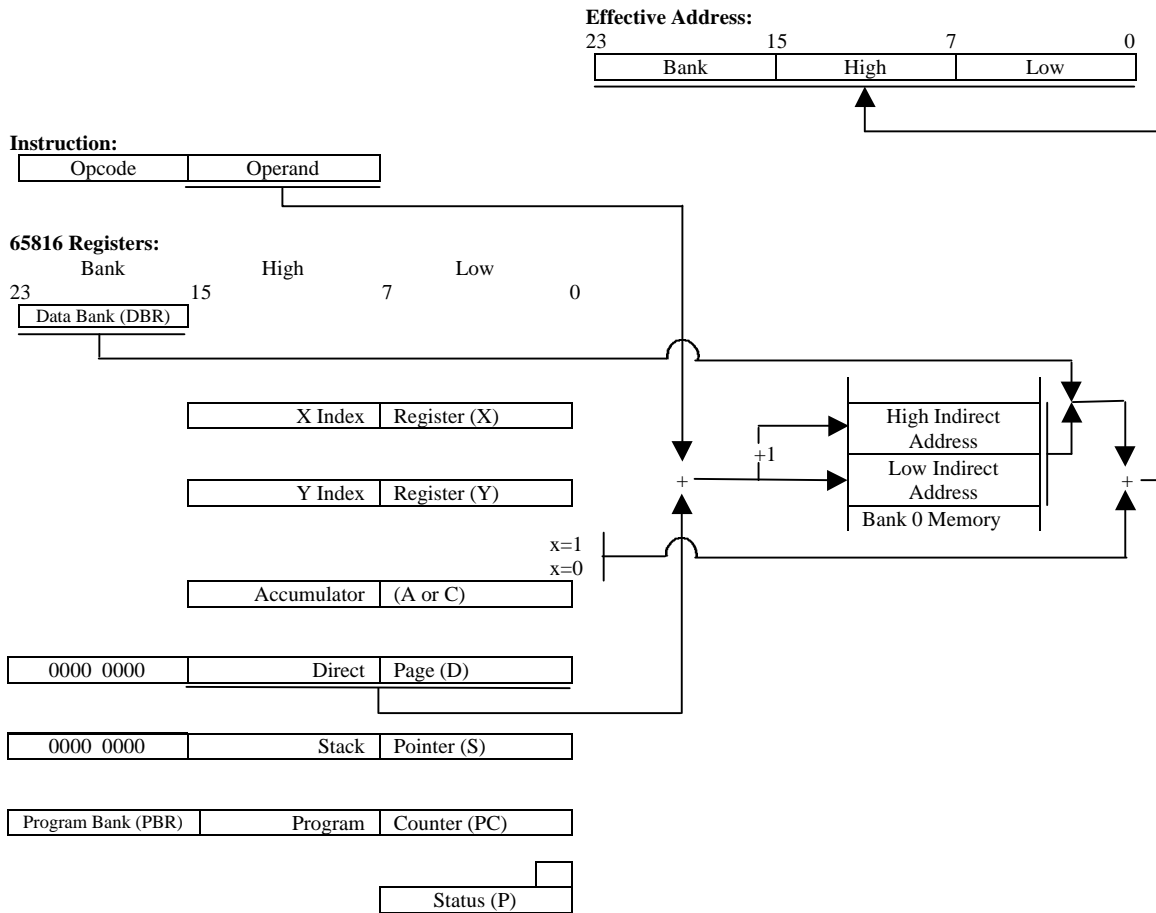

**Instruction Using It:**

Effective Address Locates Data

ADC	CMP	LDA	SBC
AND	EOR	ORA	STA



**The Western Design Center**

***Direct Page Indirect Long Indexed, Y Addressing***

**Effective Address:** Found by adding to the triple-byte indirect address Y (16 bits if 65802/65816 native mode, x = 0; else 8 bits).

**Indirect Address:** Located in the Direct Page at the sum of the direct page register and the operand byte in bank zero.

**Sample Syntax:**  
LDA (dp), Y

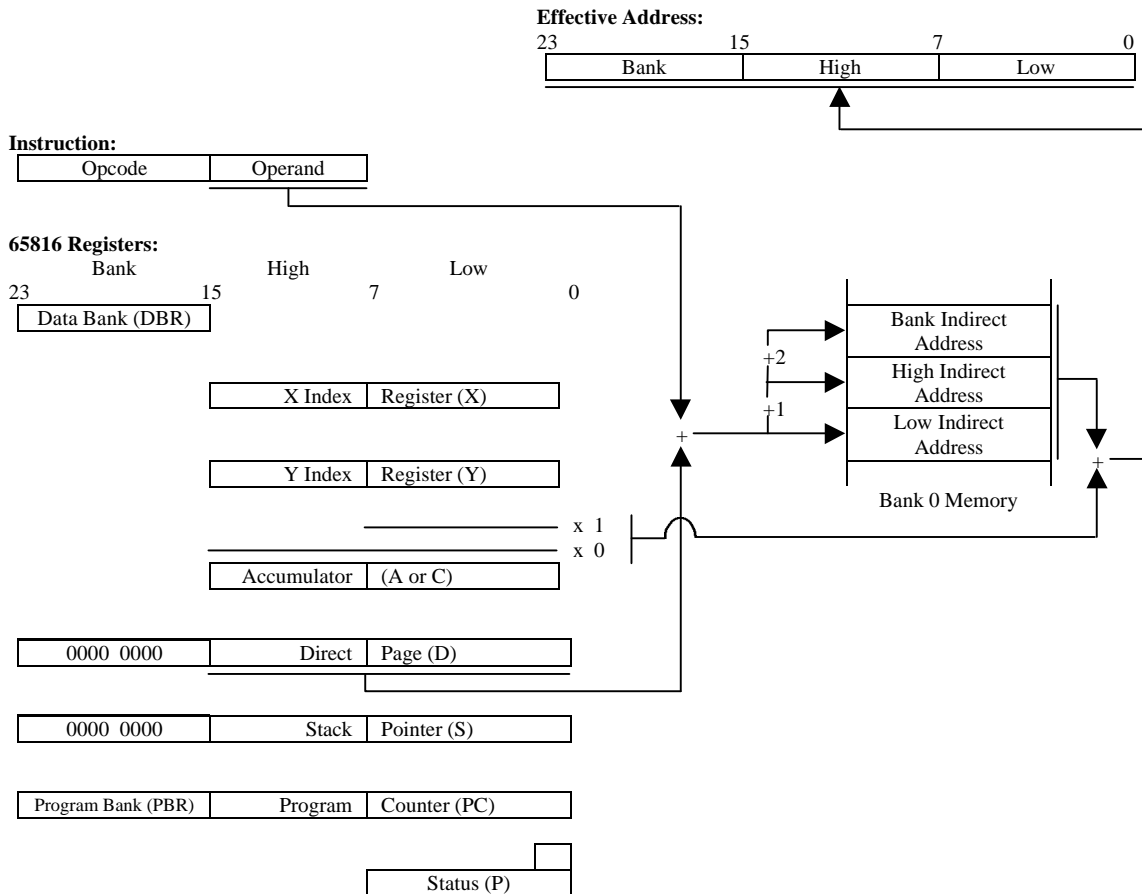

**Instructions Using It:**

Effective Address Locates Data

ADC	CMP	LDA	SBC
AND	EOR	ORA	STA

Note: All are 65802/65816 only;  
65802: Data bank value is not propagated to the bus  
(bank accessed is always bank 0).

**The Western Design Center**

**Immediate Addressing**

**8-Bit Data (all processors):** Data Operand byte.

**16-Bit Data (65802/65816, native mode, applicable mode flag m or x = 0):**

Data High: Second Operand byte.

Data Low: First Operand byte.

**Sample Syntax:**

LDA *const.*

**Instruction:**

Opcode	Data Low = Operand Low	Data High = Operand High
--------	------------------------	--------------------------

**Instruction:**

Opcode	Data = Operand
--------	----------------

**65816 Registers:**

Bank	High	Low
23                      15	7	0
Data Bank (DBR)		

X Index	Register (X)
---------	--------------

Y Index	Register (Y)
---------	--------------

Accumulator	(A or C)
-------------	----------

0000 0000	Direct	Page Register (D)
-----------	--------	-------------------

0000 0000	Stack	Pointer (S)
-----------	-------	-------------

Program Bank (PBR)	Program	Counter (PC)
--------------------	---------	--------------

Status (P)	
------------	--

**Instructions Using It:**

ADC	CPX	LDX	SBC
AND	CPY	LDY	SEP <sup>1</sup>
BIT <sup>1</sup>	EOR	ORA	
CMP	LDA	REP <sup>1</sup>	

1. 65C02 and 65802/65816 only.  
 2. 65802/65816 only.

**The Western Design Center**

***Implied Addressing***

**Type 1:** Mnemonic specifies register(s) to be operated on

**Type 2:** Mnemonic specifies flag bit(s) to be operated on

**Type 3:** Mnemonic specifies operation; no data involved

**Sample Syntax:**

NOP

**Instruction:**

Opcode
--------

**65816 Registers:**

	Bank		High		Low	
23		15		7		0
Data Bank (DBR)						

X Index	Register (X)
---------	--------------

Y Index	Register (Y)
---------	--------------

Accumulator	(A or C)
-------------	----------

0000 0000	Direct	Page Register (D)
-----------	--------	-------------------

0000 0000	Stack	Pointer (S)
-----------	-------	-------------

Program Bank (PBR)	Program	Counter (PC)
--------------------	---------	--------------

	Status (P)
--	------------

**Instructions Using It:**

Mnemonic Specifies Register(s)

DEX	TAY	TSX	TYX
DEY	TCD	TXA	XBA
INX	TCS	TXS	
INY	TDC	TXY	
TAX	TSC	TYA	

Mnemonics Specifies Flag Bit(s)

CLC	CLI	SEC	SEI
CLD	CLV	SED	XCE

Mnemonics Specifies Operation

NOP	STP	WAP
-----	-----	-----

<sup>1</sup> 65802/65816 only.

*Program Counter Relative Addressing*

**Effective Address:**

**Bank:** Program Bank Register (PBR).

**High/Low** The Operand byte, a two's complement signed value, is sign-extended to 16 bits, then added to the Program Counter (its value is the address of the opcode following this one).

**Sample Syntax:**

*BRA nearlabel*

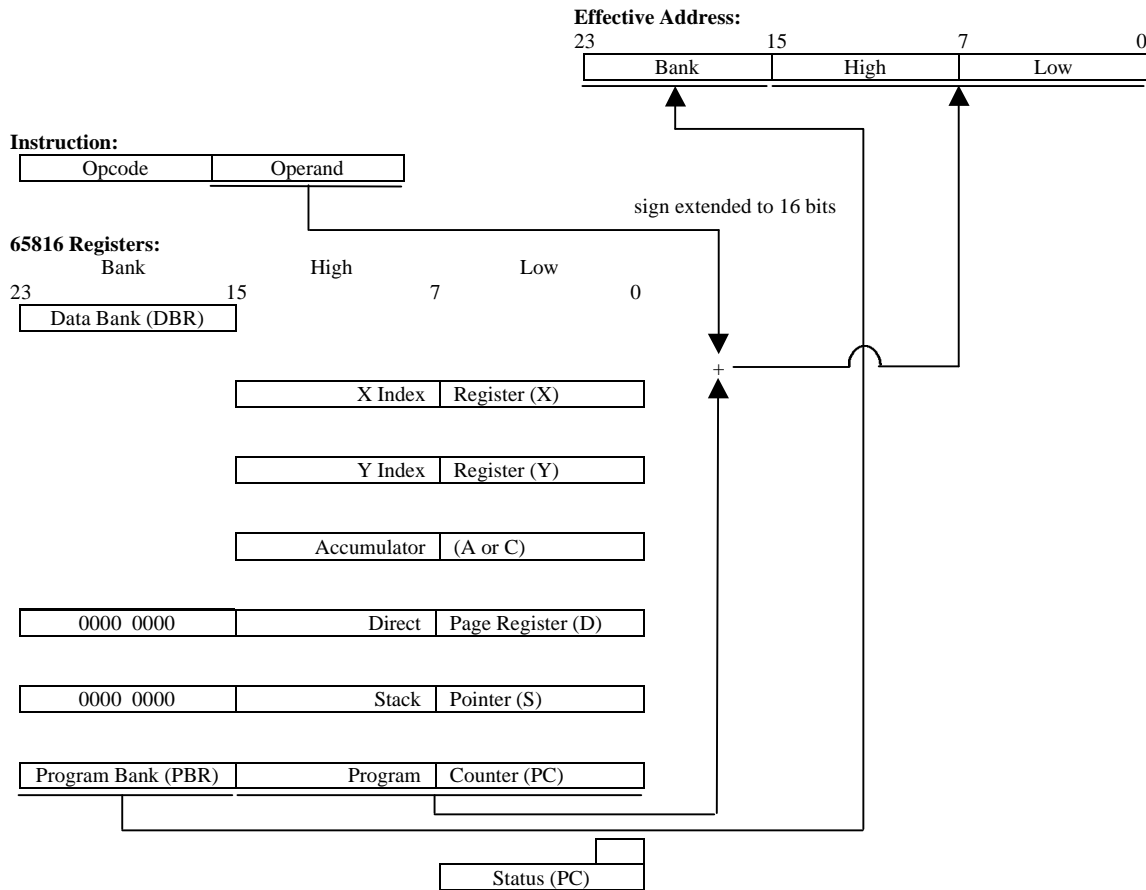

**Instructions Using It:**

Transfer Control to Effective Address

BCC	BMI	BRA <sup>1</sup>
BCS	BNE	BVC
BEQ	BPL	BVS

<sup>1</sup> 65C02 and 65802/65816 only.

**The Western Design Center**

***Program Counter Relative Long Address***

**Effective Address:**

**Bank:** Program Bank Register (PBR).

**High/Low:** The Operand double byte, a two's complement signed value, is added to the Program Counter (its value is the address of the opcode following this one).

**Sample Syntax:**

*BRL label*

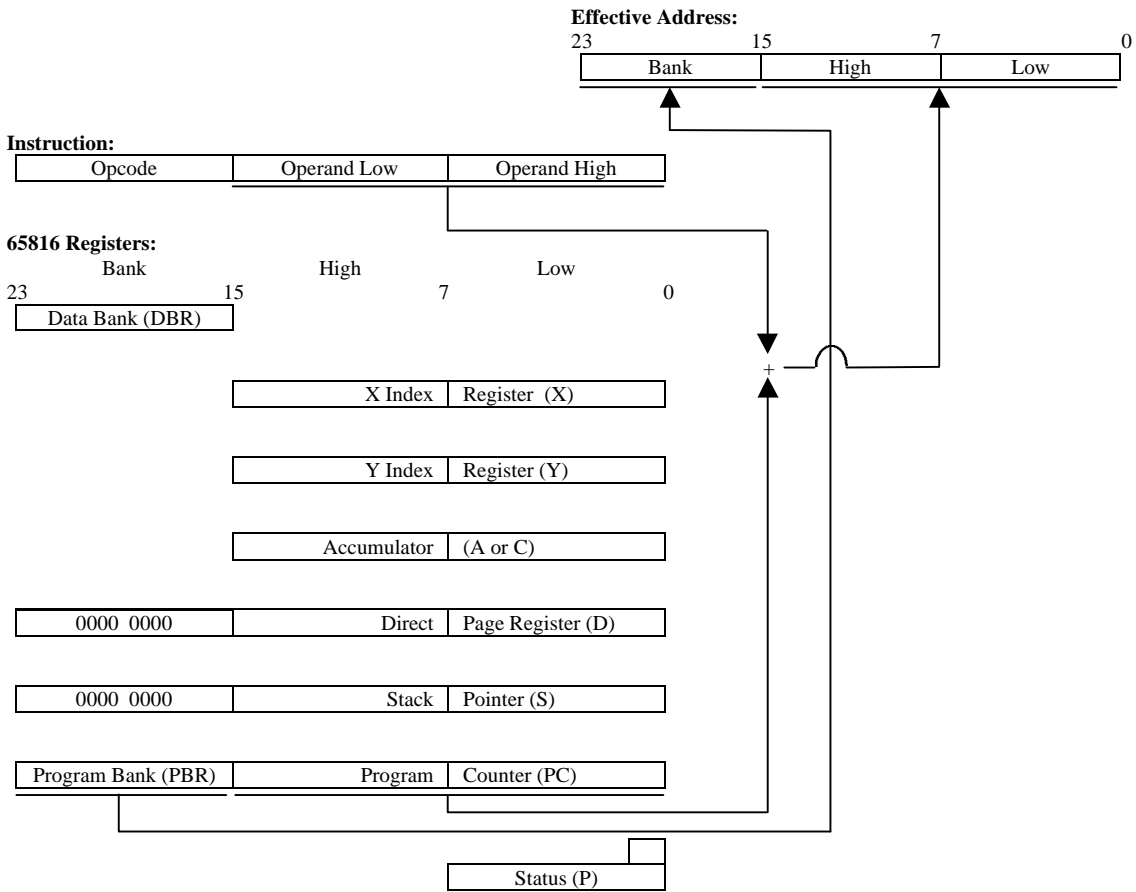

**Instructions Using It:**

Transfer Control to Effective Address  
BRL

Note: 65802/65816 only.

**The Western Design Center**

***Stack (Absolute) Addressing***

**Source of data to be pushed:** The 16-bit operand, which can be either an absolute address or immediate data.

**Destination effective address:** Provided by Stack Pointer.

**Sample Syntax:**  
PEA *addr/const*

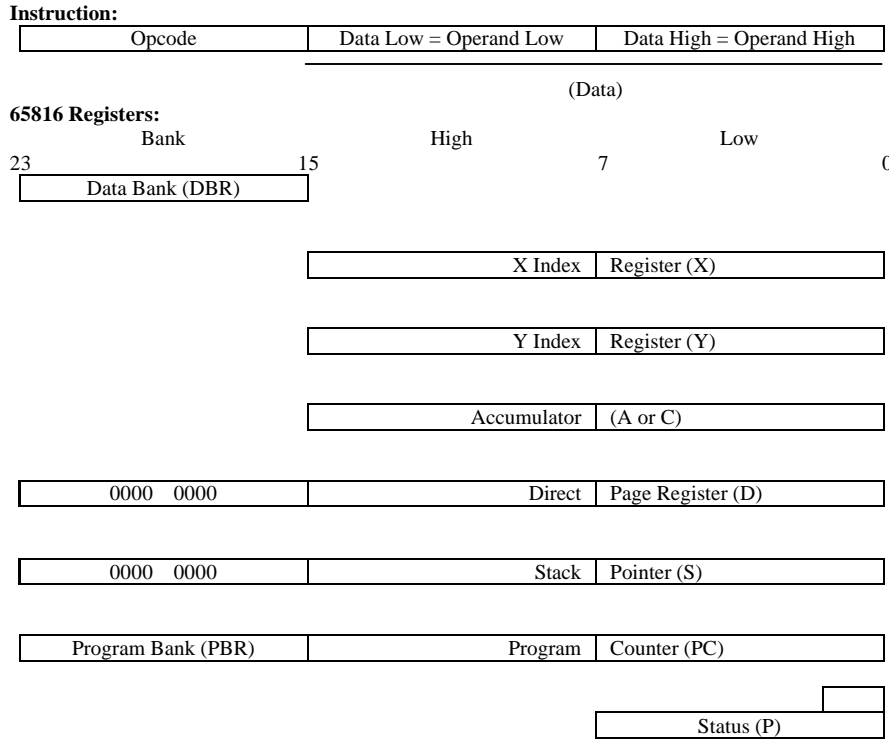

**Instruction Using It:**  
PEA  
Note: 65802/65816 only.

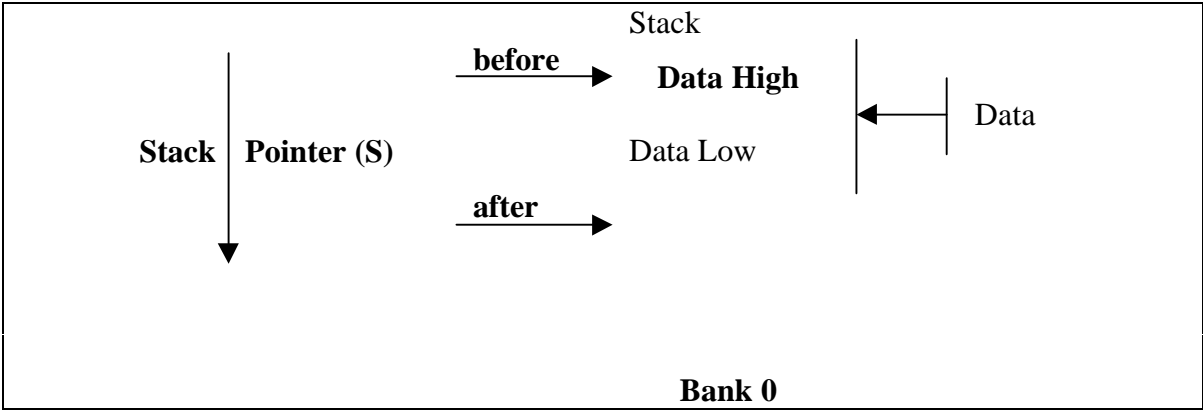

**The Western Design Center**

***Stack (Direct Page Indirect) Addressing***

**Source of data to be pushed:** The 16-bit indirect address (or double-byte data) located at the sum of the Operand byte plus the Direct Page Register, in Bank Zero.

**Destination effective address:** Provided by Stack Pointer.

**Sample Syntax:**

PEI *dp*

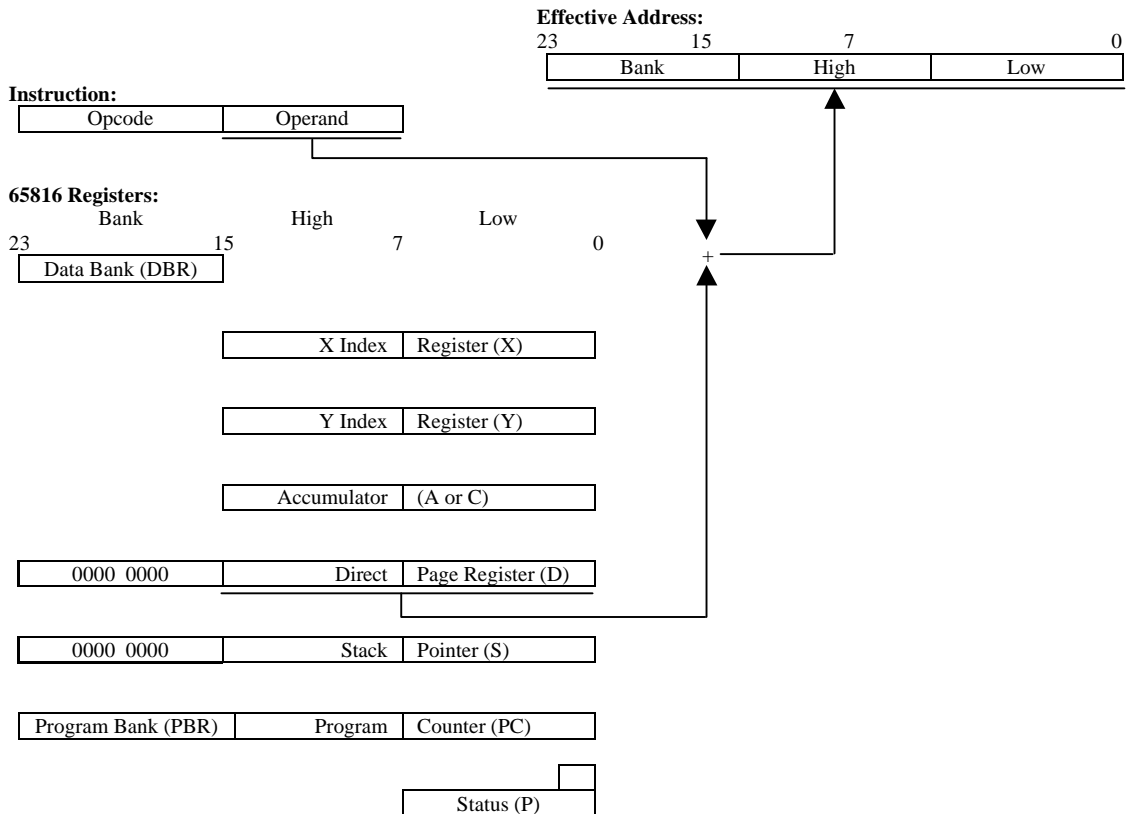

**Instruction Using It:**

Effective Address Locates Data  
PEI

Note: 65802/65816 only.



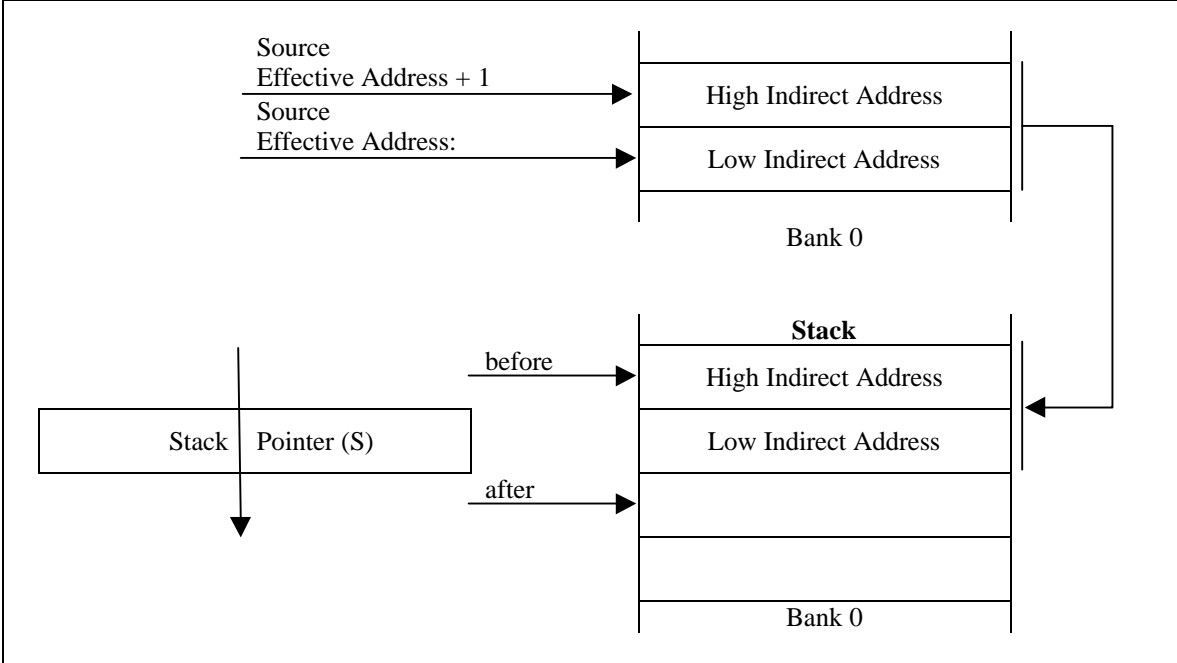

# The Western Design Center

## Stack (Interrupt) Addressing

**Effective Address:** After pushing the Program Bank (65802/816 native mode only), followed by the Program Counter and the Status Register, the Effective Address is loaded into the Program Counter and Program Bank Register, transferring control there.

**Bank:** Zero

**High/Low:** The contents of the instruction- and processor-specific interrupt vector.

**Data Source:** Program Bank, Program Counter, and Status Register.

**Destination Effective Address:** Provided by Stack Pointer.

### Sample Syntax:

BRK

#### Instruction:

Opcode	Optimal Signature Byte
--------	------------------------

Note: Hardware interrupt addressing differs only in that there is no instruction involved

#### 65816 Registers:

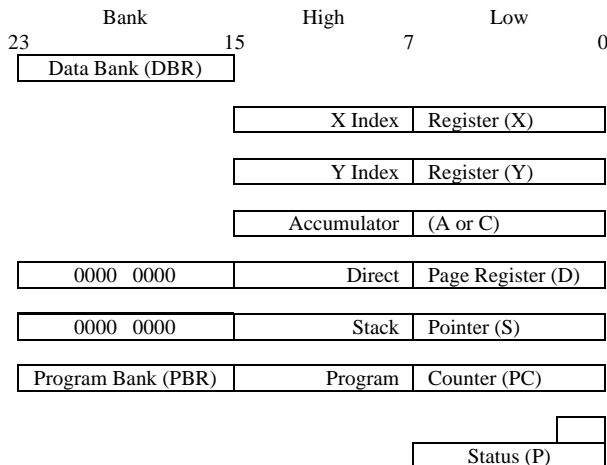

#### Effective Address:

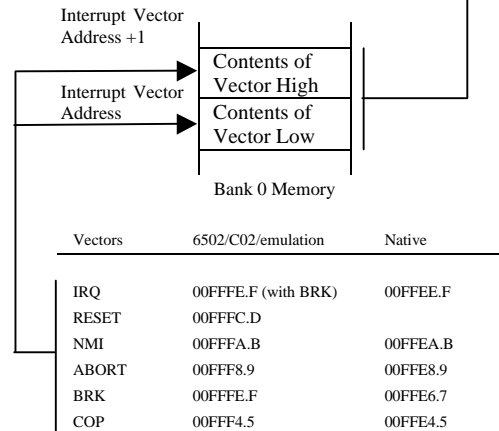
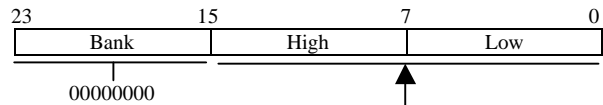

#### Instructions Using It:

Transfer Control to Effective Address
BRK
COP

Stack (Interrupt) Addressing

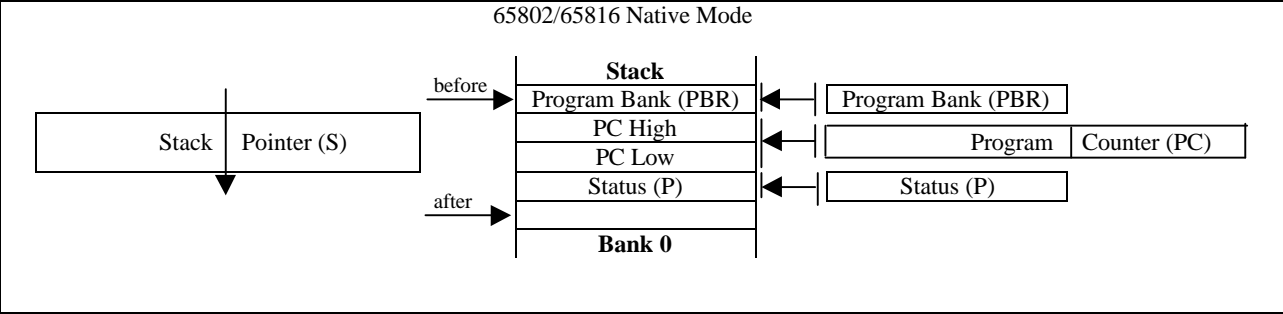
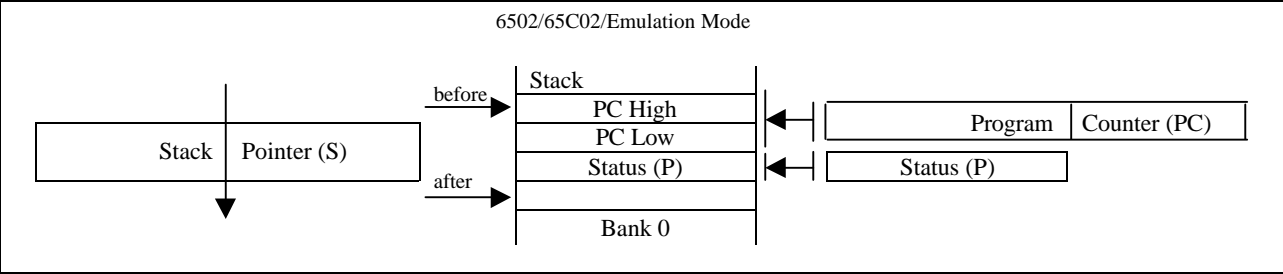

**Stack (Program Counter Relative) Addressing**

**Source of data to be pushed:** The 16-bit sum of the 16-bit Operand plus the 16-bit Program Counter. (Note that the 16-bit Operand which is added is the object code operand; the operand used in the instruction's syntax required by most assemblers is a label which is converted to the object operand.)

**Destination Effective Address:** Provided by Stack Pointer.

**Sample Syntax:**  
 PER *label*

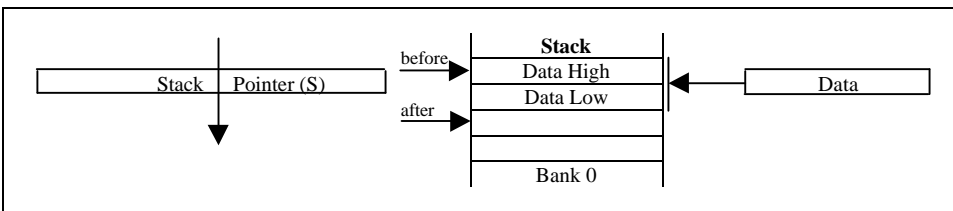
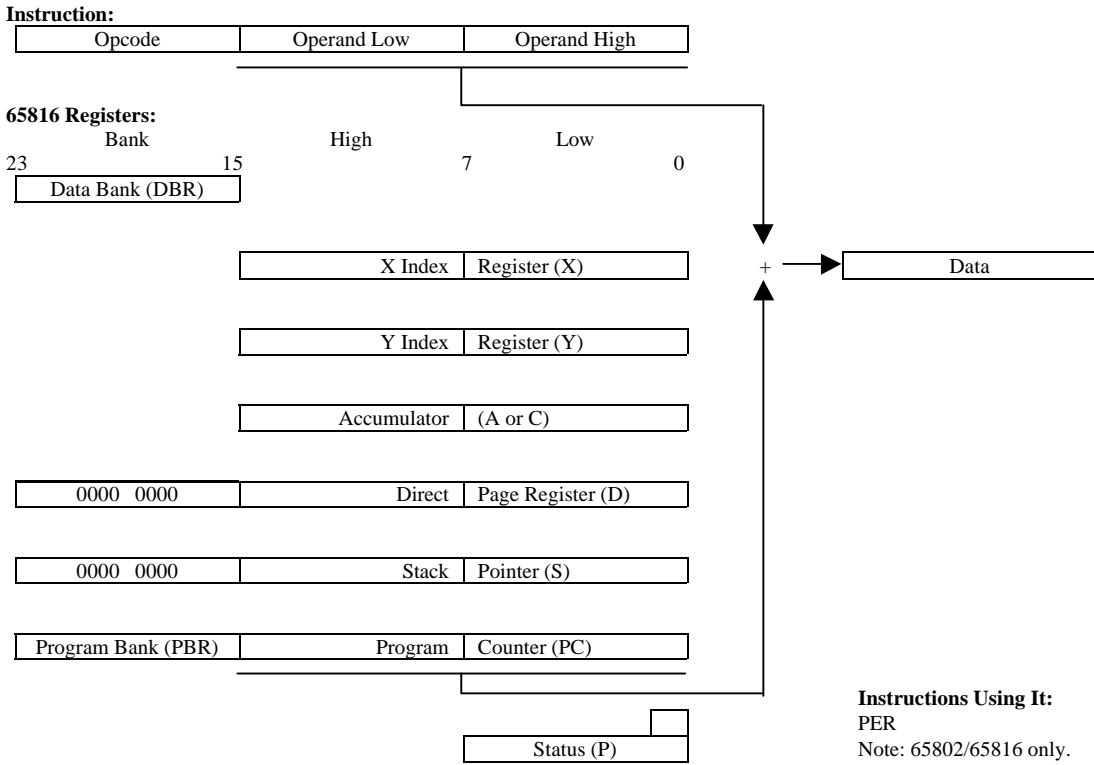

## The Western Design Center

### Stack (Pull) Addressing

**Source Effective Address:** Provided by Stack Pointer.

**Destination of data to be pulled:** Register specified by the opcode. The Stack Pointer (S) is incremented, specifying the location from which an 8-bit register – or the low byte of a 16-bit register – will be loaded. If the register is 16 bits, the Stack Pointer will be incremented a second time, and the register's high byte will be loaded from this second new Stack Pointer location.

### Sampler Syntax:

PLA

#### Instruction:

Opcode
--------

#### 65816 Registers:

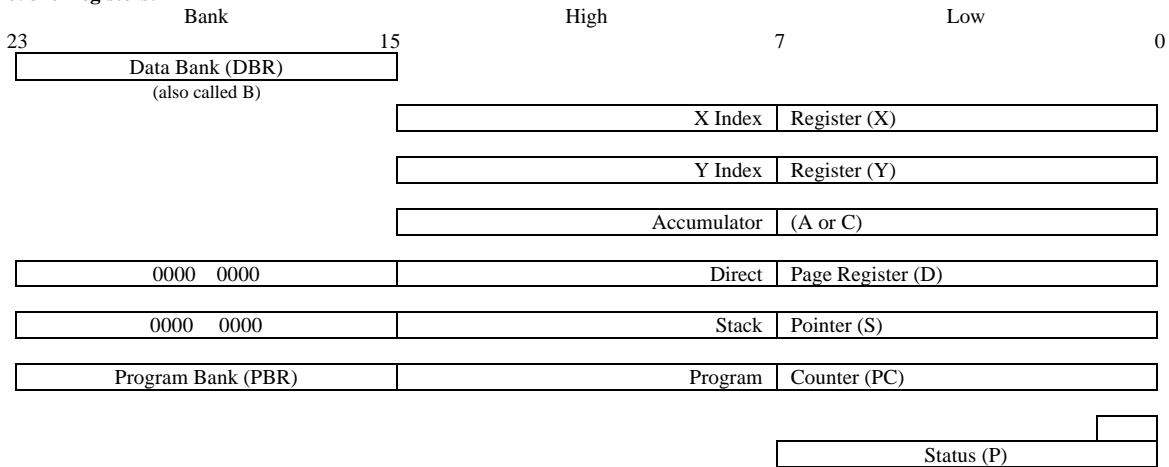

### Instruction Using It:

#### Effective Address Locates Data

PLA	PLD	PLX
PLB	PLP	`PLY

1. 65802/65816 only.
2. 8 bit register, except on 65802/816 may either 8 or 16 bits, dependent on flag m.
3. 8 bit register, except on 65802/816 may be either 8 or 16 bits, dependent on flag x.
4. 16 bits always.
5. 8 bits always.

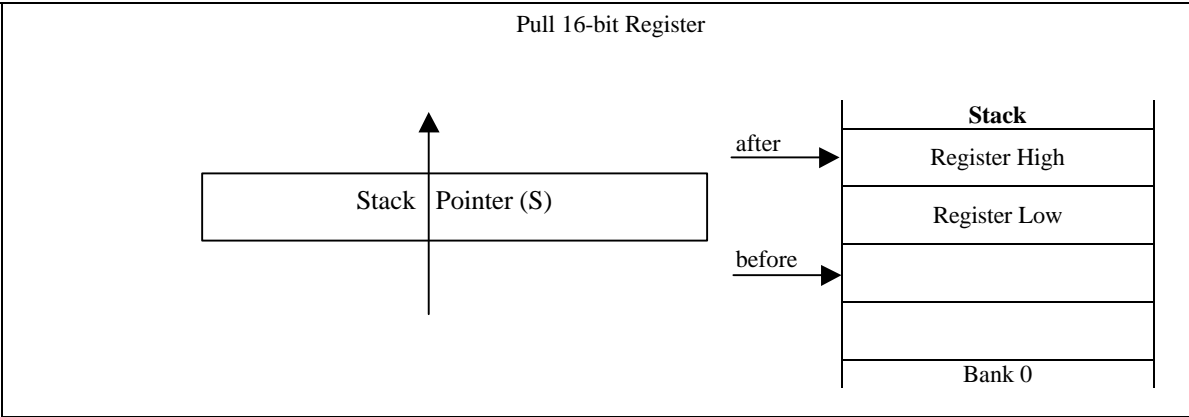
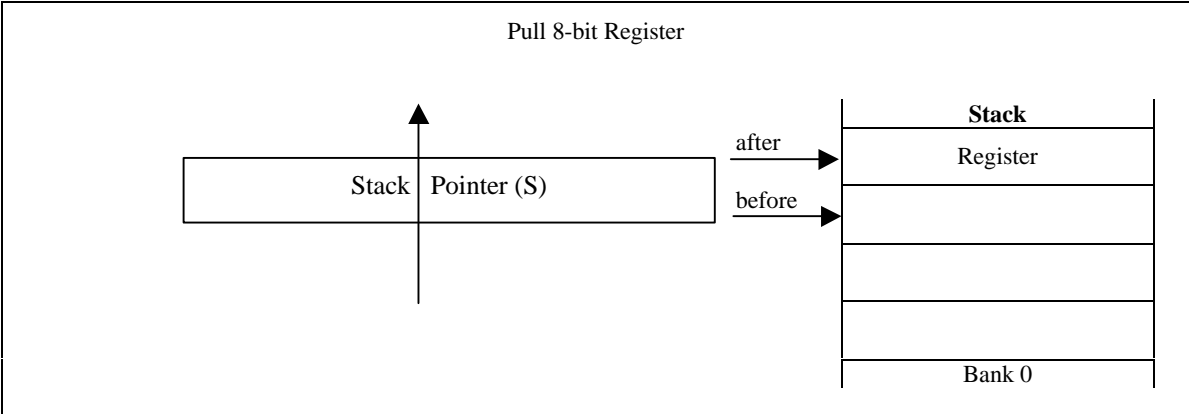

## The Western Design Center

### Stack (Push) Addressing

**Source of data to be pushed:** Register specified by the opcode.

**Destination Effective Address:** Provided by Stack Pointer.

The Stack Pointer (S) specifies the location to which an 8-bit register – or the high byte of a 16-bit register – will be stored. The low byte of a 16-bit register will be stored to the Stack Pointer location minus one. After storage of an 8-bit register, S is decremented by 1; after a 16-bit register, S is decremented by 2.

### Sample Syntax:

PHA

#### Instructions:

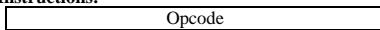

#### 65816 Registers:

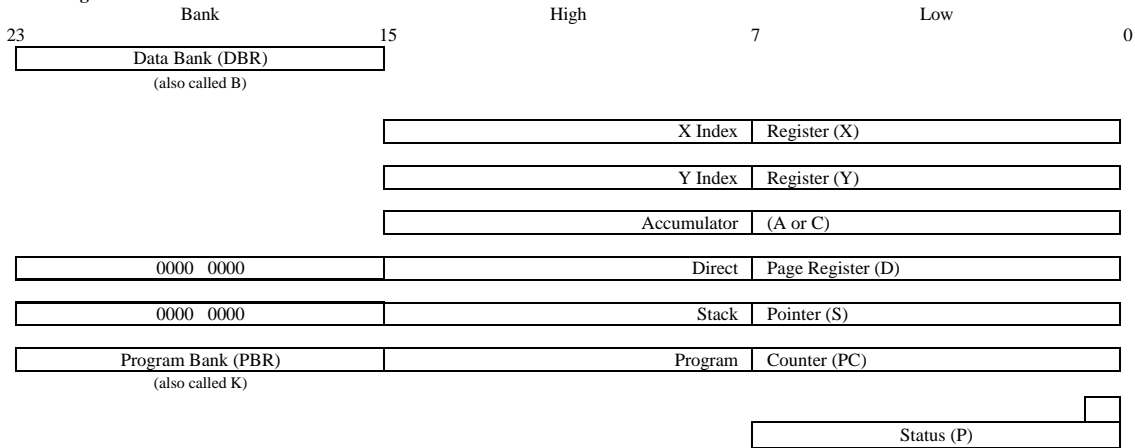

### Instruction Using It:

#### Effective Address Locates Data

PHA	PHD	PHP
PHB	PHK	PHX

- 1 65802/65816 only.
- 2 8 bit register, except on 65802/816, may be either 8 or 16 bits, dependent on flag m.
- 3 8 bit register, except on 65802/816, may be either 8 or 16 bits, dependent on flag x.
- 4 16 bit always.
- 5 8 bit always.

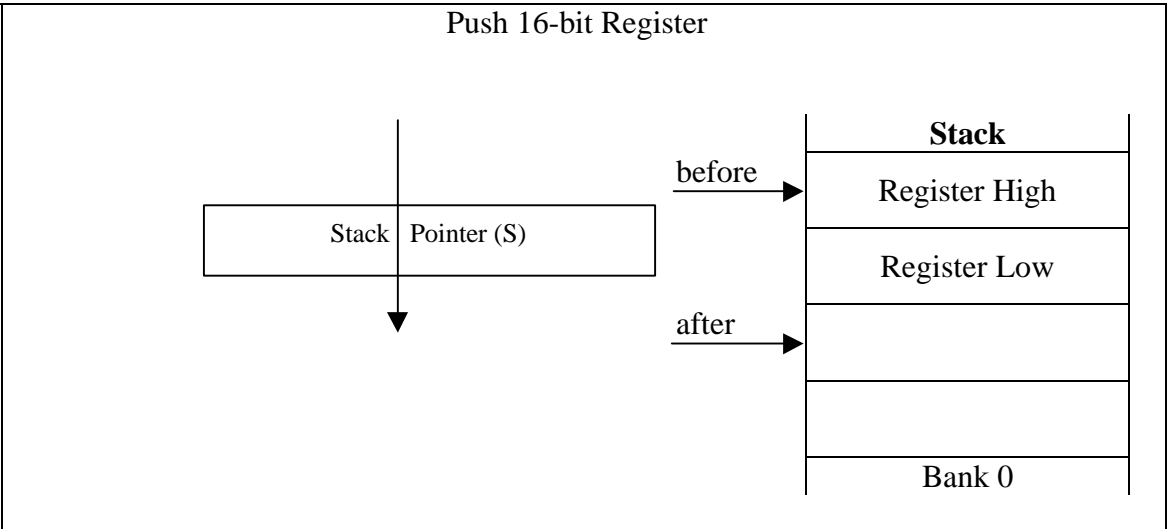
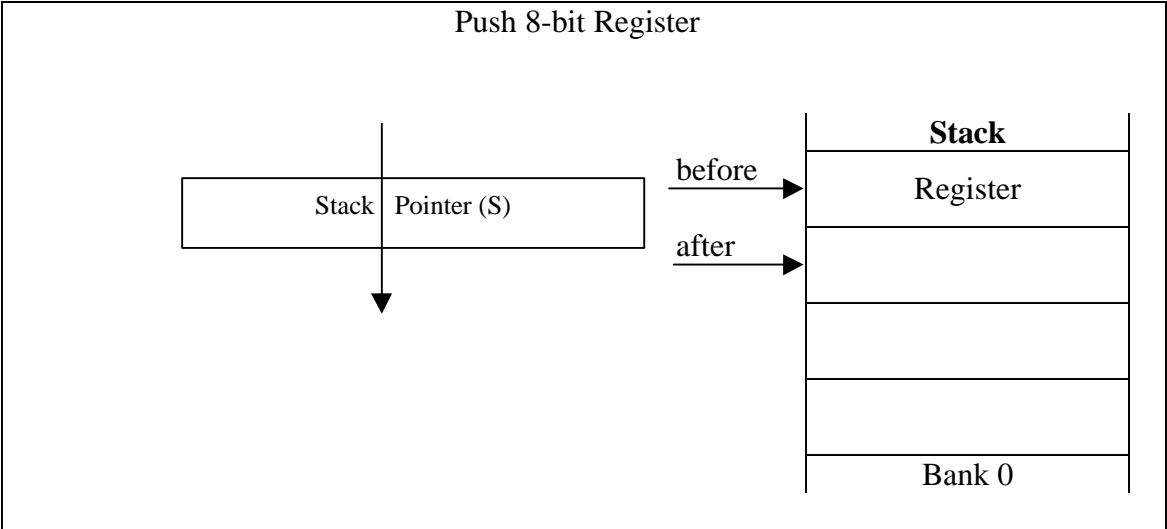



**The Western Design Center**

**Stack (RTI) Addressing**

**Source Effective Address:** Provided by Stack Pointer.

**Destination of values to be pulled:** First the Status Register, then the Program Counter is pulled, followed (65802/65816 native mode only) by the Program Bank.

Control is transferred to the new Program Counter (and Program Bank) value(s).

**Sample Syntax:**

RTI

**Instruction:**

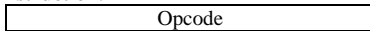

**65816 Registers:**

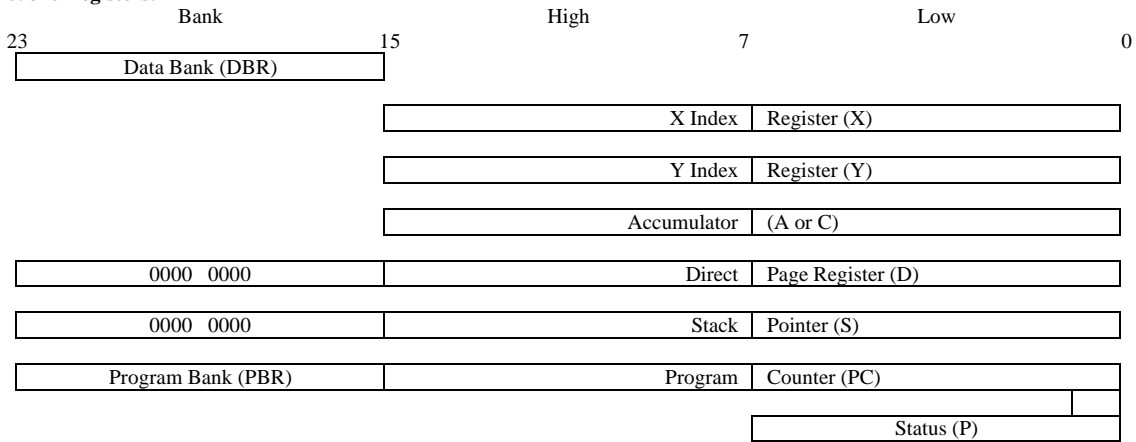

**Instructions Using It:**

RTI

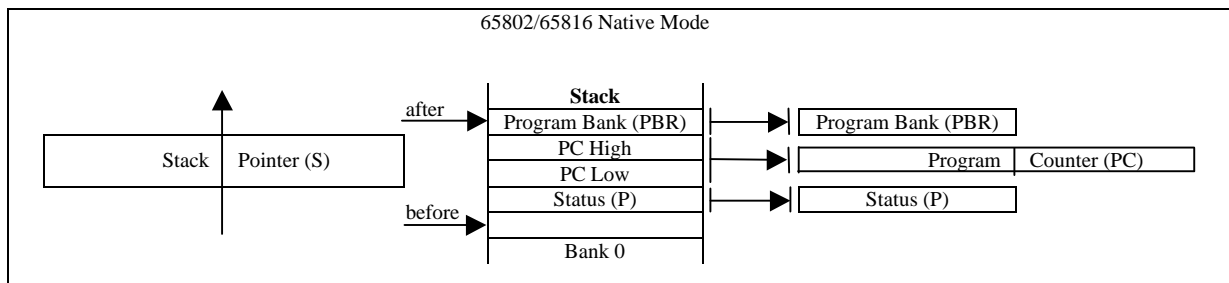
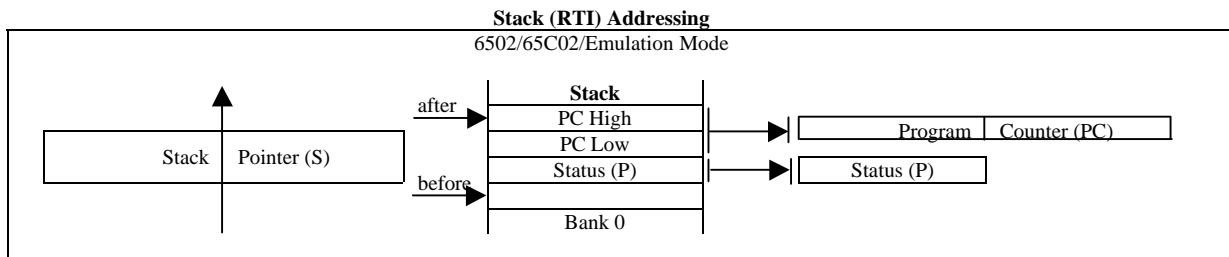

# The Western Design Center

## Stack (RTL) Addressing

**Source Effective Address:** Provided by Stack Pointer.

**Destination of values to be pulled:** First the Program Counter is pulled and incremented by one. Then the Program Bank is pulled back.

### Sample Syntax:

RTL

**Instruction:**

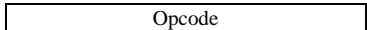

**65816 Registers:**

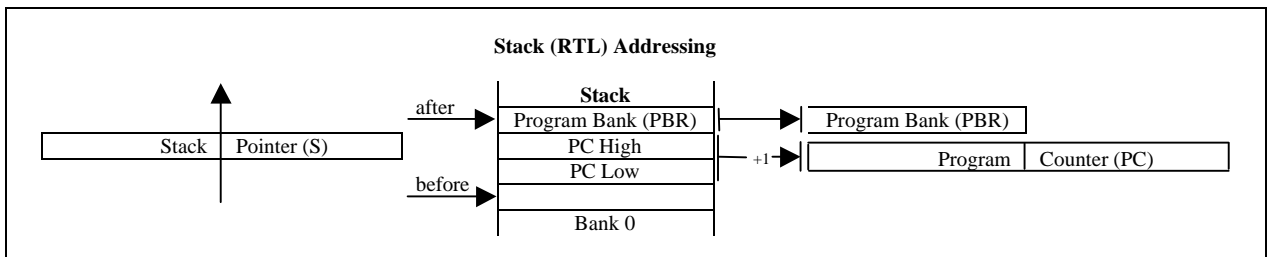
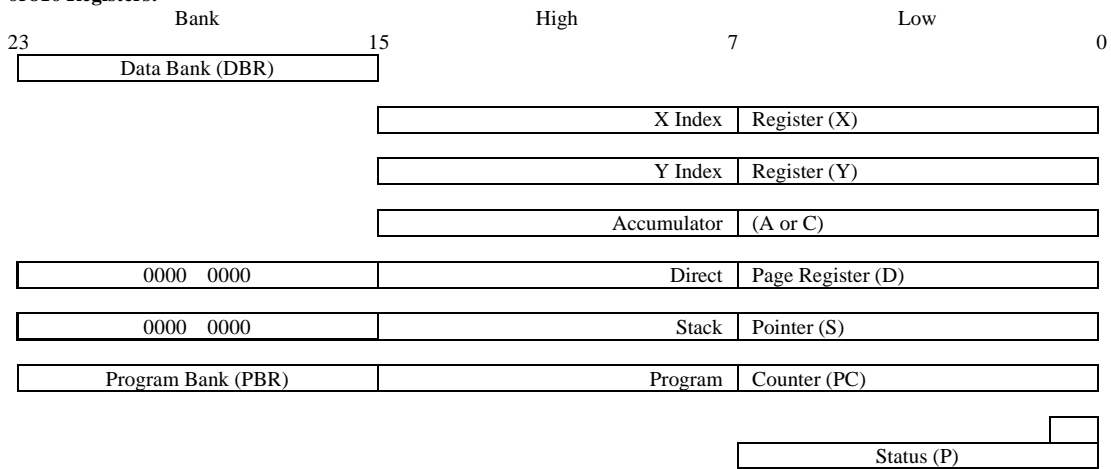

**The Western Design Center**

**Stack (RTS) Addressing**

**Source Effective Address:** Provided by Stack Pointer.

**Destination of values to be pulled:** The Program Counter is pulled and incremented by one. The Program Bank remains unchanged.

Control is transferred to the new Program Counter value.

**Sample Syntax:**

RTS

**Instruction:**

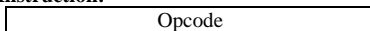

**65816 Registers:**

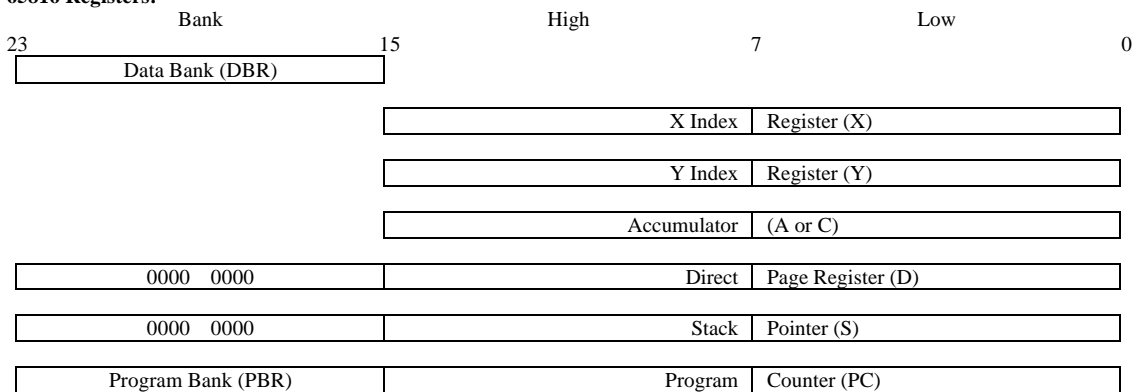

**Instruction Using It:**

RTS

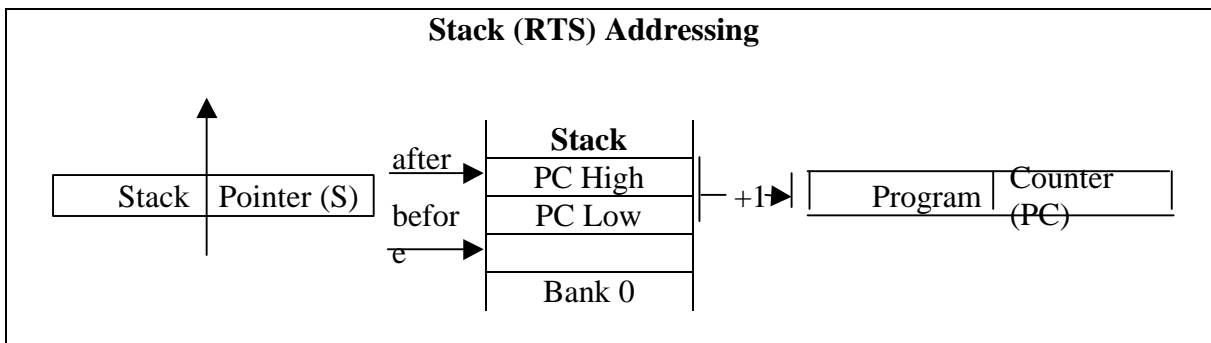
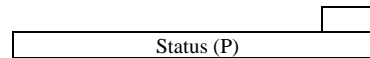

**The Western Design Center**

**Stack Relative Addressing**

**Effective Address:**

Bank: Zero.

High/Low: The 16-bit sum of the 8-bit Operand and the 16-bit Stack Pointer.

**Sample Syntax:**

LDA *sr,S*

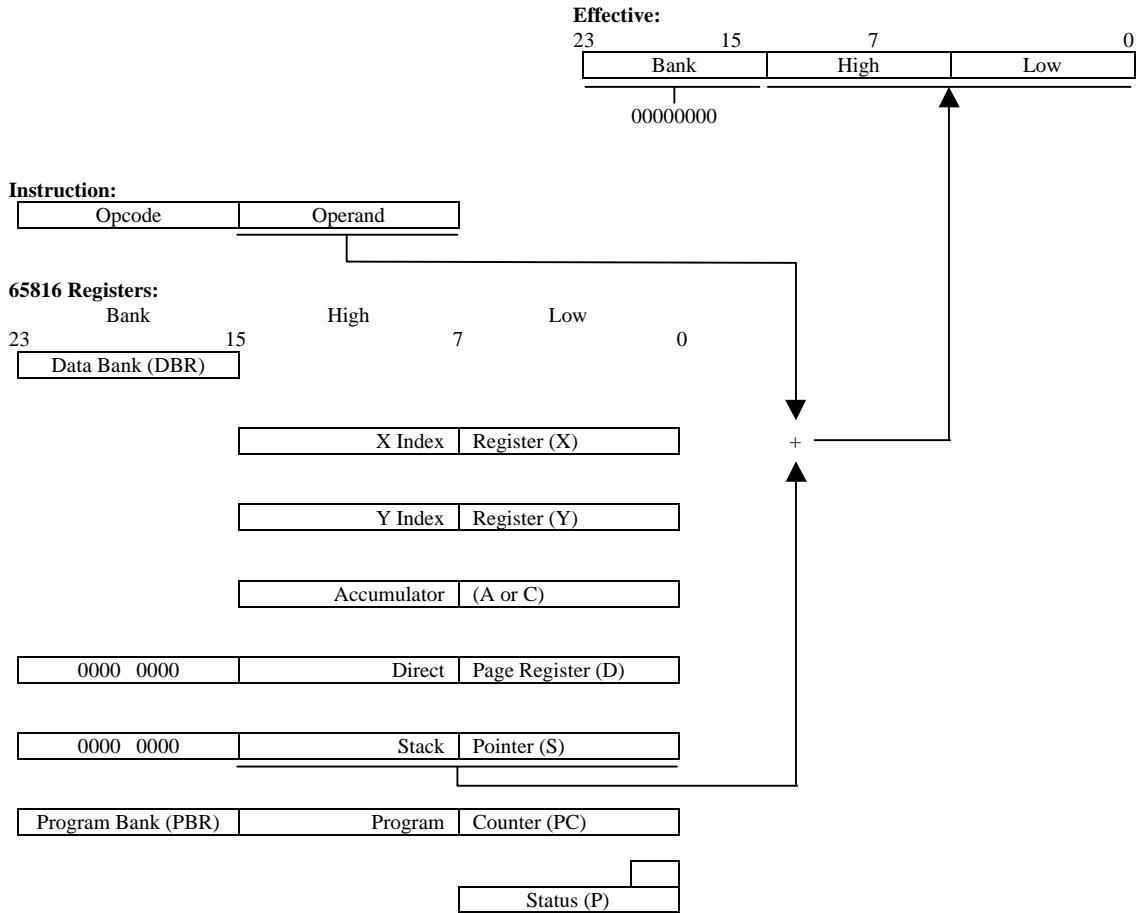

**Instruction Using It:**

Effective Address Locates Data

ADC           CMP  
AND           EOR

Note: All are 65802/65816 only.

**Stack Relative Indirect Indexed, Y Addressing**

**Effective Address:** The Data Bank Register is concatenated to the Indirect Address; the 24-bit result is added to Y (16 bits if 65802/65816 native mode, x = 0; else 8 bits).

Indirect Address: Located at the 16-bit sum of the 8-bit Operand and the 16-bit Stack Pointer.

**Sample Syntax:**

LDA (sr,S),Y

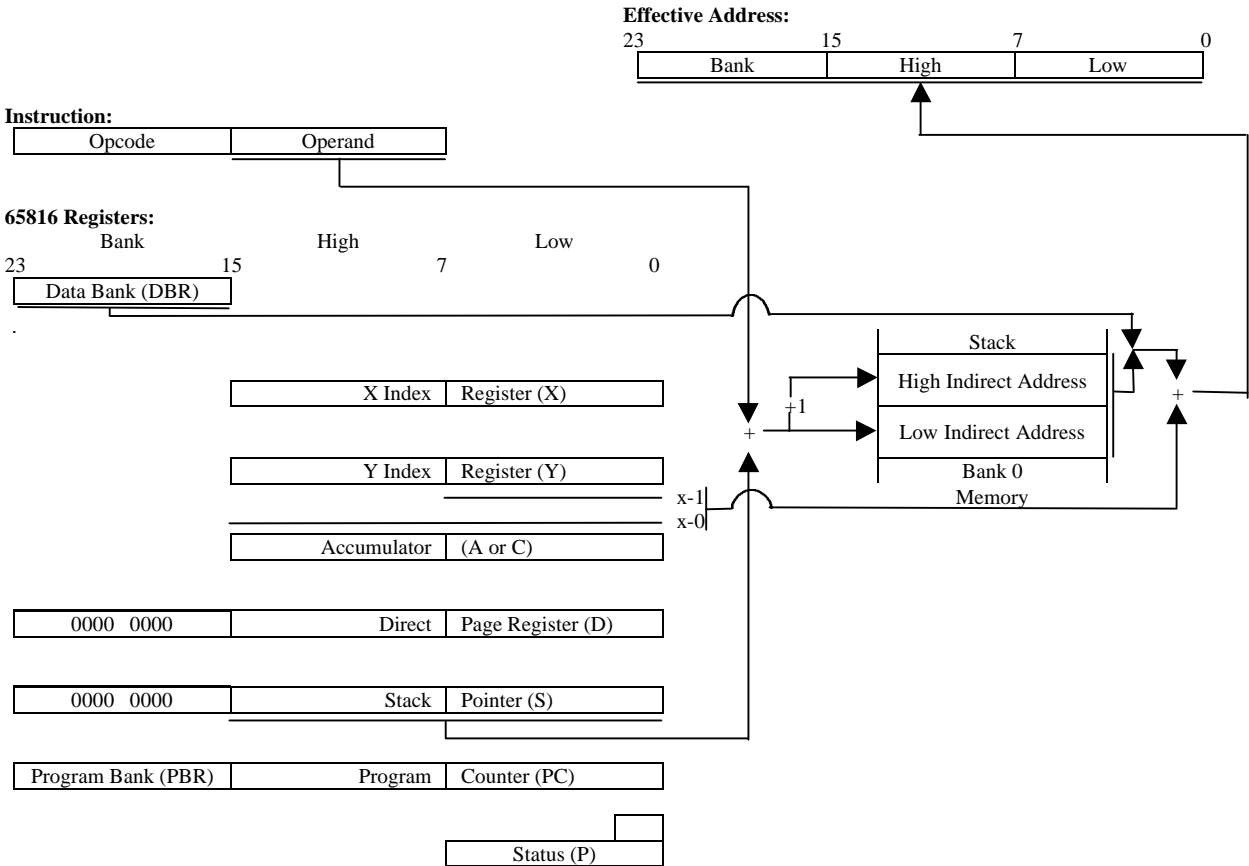

**Instructions Using It:**

Effective Address Locates Data

ADC	CMP	LDA	SBC
AND	EOR	ORA	STA

Note: All are 65802/65816 only;  
65802: Data bank value is not propagated to the bus  
(bank accessed is always bank 0).

# 18) Chapter Eighteen

## The Instruction Sets

This chapter devotes a page to each of the 94 different 65816 operations. Each operation may have more than one addressing mode available to it; these are detailed for each instruction. The symbols in Table 18.1 are used to express the different kinds of values that instruction operands may have. The effect of each operation on the status flags varies. The symbols in Table 18.2 are used to indicate the flags that are affected by a given operation.

addr	two-byte address
addr / const	two-byte value: either an address or a constant
const	one- or two-byte constant
destbk	64K bank to which string will be moved
dp	one-byte direct page offset (6502/65C02: zero page)
label	label of code in same 64 bank as instruction
long	three-byte address (includes bank byte)
nearlabel	label of code close enough to instruction to be reachable by a one-byte signed offset
sr	one-byte stack relative offset
srcebk	64K bank from which string will be moved

**Table 18-1 Operand Symbols**

<b>Flags:</b>	
bits:	7 6 5 4 3 2 1 0
6502/65C02/6502 emulation:	n v - b d i z c
65802/65816 native:	n v m x d i z c
	n — negative result
	v — overflow
	m — 8-bit memory/accumulator
	x — 8-bit index registers
	b — BRK caused interrupt
	d — decimal mode
	i — IRQ interrupt disable
	z — zero result
	c — carry

**Table 18-2 65x Flags**

## Add With Carry

## ADC

Add the data located at the effective address specified by the operand to the contents of the accumulator; add one to the result if the carry flag is set, and store the final result in the accumulator.

The 65x processors have no add instruction that does not involve the carry. To avoid adding the carry flag to the result, you must either be sure that it is already clear, or you must explicitly clear it (using **CLC**) prior to executing the **ADC** instruction.

In a multi-precision (multi-word) addition, the carry should be cleared before the low-order words are added; the addition of the low word will generate a new carry flag value based on the addition. This new value in the carry flag is added into the next (middle-order or high-order) addition; each intermediate result will correctly reflect the carry from the previous addition.

**d flag clear:** Binary addition is performed.

**d flag set:** Binary coded decimal (BCD) addition is performed.

**8-bit accumulator (all processors):** Data added from memory is eight-bit.

**16-bit accumulator (65802/65816 only, m = 0):** Data added from memory is sixteen-bit: the low-order eight bits are located at the effective address; the high-order eight bits are located at the effective address plus one.

## Flags Affected:

**n v — — — z c**

**n** Set if most significant bit of result is set; else cleared.

**v** Set if signed overflow; cleared if valid signed result.

**z** Set if result is zero; else cleared.

**c** Set if unsigned overflow; cleared if valid unsigned result.

## Codes:

Addressing Mode <sup>++</sup>	Syntax	Opcode (hex)	Available on:			# of Bytes	# of Cycles
			6502	65C02	65802/816		
Immediate	<b>ADC #const</b>	69	x	x	x	2*	2 <sup>1,4</sup>
Absolute	<b>ADC addr</b>	6D	x	x	x	3	4 <sup>1,4</sup>
Absolute Long	<b>ADC long</b>	6F			x	4	5 <sup>1,4</sup>
Direct Page (DP)	<b>ADC dp</b>	65	x	x	x	2	3 <sup>1,2,4</sup>
DP Indirect	<b>ADC (dp)</b>	72		x	x	2	5 <sup>1,2,4</sup>
DP Indirect Long	<b>ADC [dp]</b>	67			x	2	6 <sup>1,2,4</sup>
Absolute Indexed, X	<b>ADC addr, X</b>	7D	x	x	x	3	4 <sup>1,3,4</sup>
Absolute Long Indexed, X	<b>ADC long, X</b>	7F			x	4	5 <sup>1,4</sup>
Absolute Indexed Y	<b>ADC addr, Y</b>	79	x	x	x	3	4 <sup>1,3,4</sup>
DP Indexed, X	<b>ADC dp, X</b>	75	x	x	x	2	4 <sup>1,2,4</sup>
DP Indexed Indirect, X	<b>ADC (dp, X)</b>	61	x	x	x	2	6 <sup>1,2,4</sup>
DP Indirect Indexed, Y	<b>ADC (dp), Y</b>	71	x	x	x	2	5 <sup>1,2,3,4</sup>
DP Indirect Long Indexed, Y	<b>ADC [dp], Y</b>	77			x	2	6 <sup>1,2,4</sup>
Stack Relative (SR)	<b>ADC sr, S</b>	63			x	2	4 <sup>1,4</sup>
SR Indirect Indexed, Y	<b>ADC (sr, S), Y</b>	73			x	2	7 <sup>1,4</sup>

<sup>++</sup> ADC, a Primary Group Instruction, has available all of the Primary Group addressing modes and bit patterns

\* Add 1 byte if m = 0 (16-bit memory/accumulator)

<sup>1</sup> Add 1 cycle if m = 0 (16-bit memory/accumulator)

<sup>2</sup> Add 1 cycle if low byte of Direct Page register is other than zero (DL < >0)

<sup>3</sup> Add 1 cycle if adding index crosses a page boundary

<sup>4</sup> Add 1 cycle if 65C02 and d = 1 (decimal mode, 65C02)

**And Accumulator with Memory**

**AND**

Bitwise logical AND the data located at the effective address specified by the operand with the contents of the accumulator. Each bit in the accumulator is ANDed with the corresponding bit in memory, with the result being stored in the respective accumulator bit.

The truth table for the logical AND operation is:

		<i>Second Operand</i>	
		0	1
<b>First Operand</b>	0	0	0
	1	0	1

**Figure 18-1 AND Truth Table**

That is, a 1 or logical true results in given bit being true only if both elements of the respective bits being ANDed are 1s, or logically true.

**8-bit accumulator (all processors):** Data ANDed from memory is eight-bit.

**16-bit accumulator (65802/65816 only, m = 0):** Data ANDed from memory is sixteen-bit: the low-order byte is located at the effective address; the high-order byte is located at the effective address plus one.

Flags Affected: n - - - - z -

- n Set if most significant bit of result is set; else cleared.
- z Set if result is zero; else cleared.

**Codes:**

<i>Addressing Mode</i> <sup>++</sup>	<i>Syntax</i>	<i>Opcode (hex)</i>	<i>Available on:</i>			<i># of Bytes</i>	<i># of Cycles</i>
			6502	65C02	65802/816		
Immediate	<b>AND # const</b>	29	x	x	x	2*	2 <sup>1</sup>
Absolute	<b>AND addr</b>	2D	x	x	x	3	4 <sup>1</sup>
Absolute Long	<b>AND long</b>	2F			x	4	5 <sup>1</sup>
Direct Page (DP)	<b>AND dp</b>	25	x	x	x	2	3 <sup>1,2</sup>
DP Indirect	<b>AND(dp)</b>	32		x	x	2	5 <sup>1,2</sup>
DP Indirect Long	<b>AND [dp]</b>	27			x	2	6 <sup>1,2</sup>
Absolute Indexed, X	<b>AND addr, X</b>	3D	x	x	x	3	4 <sup>1,3</sup>
Absolute Long Indexed, X	<b>AND long, X</b>	3F			x	4	5 <sup>1</sup>
Absolute Indexed, Y	<b>AND addr, Y</b>	39	x	x	x	3	4 <sup>1,3</sup>
DP Indexed, X	<b>AND dp, X</b>	35	x	x	x	2	4 <sup>1,2</sup>
DP Indexed Indirect, X	<b>AND (dp, X)</b>	21	x	x	x	2	6 <sup>1,2</sup>
DP Indirect Indexed, Y	<b>AND (dp), Y</b>	31	x	x	x	2	5 <sup>1,2,3</sup>
DP Indirect Long Indexed, Y	<b>AND [dp], Y</b>	37			x	2	6 <sup>1,2,0</sup>
Stack Relative (SR)	<b>AND sr, S</b>	23			x	2	4 <sup>1</sup>
SR Indirect Indexed, Y	<b>AND (sr, S), Y</b>	33			x	2	7 <sup>1</sup>

<sup>++</sup> AND, a Primary Group Instruction, has available all of the Primary Group addressing modes and bit patterns

\* Add 1 byte if m = 0 (16-bit memory/accumulator)

<sup>1</sup> Add 1 cycle if m = 0 (16-bit memory/accumulator)

<sup>2</sup> Add 1 cycle if low byte of Direct Page register is other than zero (DL < > 0)

<sup>3</sup> Add 1 cycle if adding index crosses a page boundary



**Shift Memory or Accumulator Left**

**ASL**

Shift the contents of the location specified by the operand left one bit. That is, bit one takes on the value originally found in bit zero, bit two takes the value originally in bit one, and so on; the leftmost bit (bit 7 on the 6502 and 65C02 or if **m** = 1 on the 65802/65816, or bit 15 if **m** = 0) is transferred into the carry flag; the rightmost bit, bit zero, is cleared. The arithmetic result of the operation is an unsigned multiplication by two.

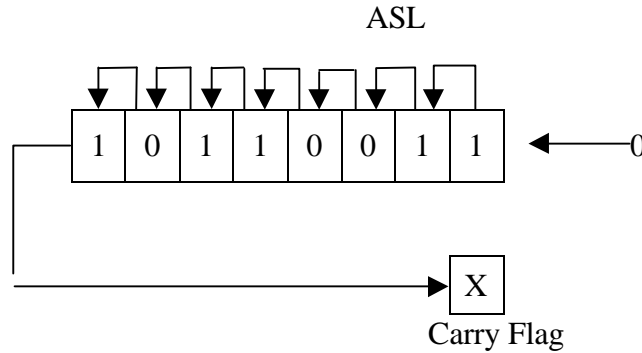

**Figure 18-2 ASL**

**8-bit accumulator/memory (all processors):** Data shifted is eight bits.

**16-bit accumulator/memory (65802/65816 only, m = 0):** Data shifted is sixteen bits: if in memory, the low-order eight bits are located at the effective address; the high-order eight bits are located at the effective address plus one.

**Flags Affected:** n - - - - z c

- n Set if most significant bit of result is set; else cleared.
- z Set if result is zero; else cleared.
- c High bit becomes carry: set if high bit was set; cleared if high bit was zero.

**Codes:**

<i>Addressing Mode</i>	<i>Syntax</i>	<i>Opcod e (hex)</i>	<i>Available on:</i>			<i># of Bytes</i>	<i># of Cycles</i>
			6502	65C02	65802/816		
Accumulator	<b>ASL A</b>	0A	x	x	x	1	2
Absolute	<b>ASL addr</b>	0E	x	x	x	3	6 <sup>1</sup>
Direct Page (DP)	<b>ASL dp</b>	06	x	x	x	2	5 <sup>1,2</sup>
Absolute Indexed, X	<b>ASL addr, X</b>	1E	x	x	x	3	7 <sup>1,3</sup>
DP Indexed, X	<b>ASL dp, X</b>	16	x	x	x	2	6 <sup>1,2</sup>

- 1 Add 2 cycles if m = 0 (16-bit memory/accumulator)
- 2 Add 1 cycle if low byte of Direct Page register is other than zero (DL < > 0)
- 3 Subtract 1 cycle if 65C02 and no page boundary crossed

**Branch if Carry Clear**

**BCC**

The carry flag in the **P** status register is tested. If it is clear, a branch is taken; if it is set, the instruction immediately following the two-byte **BCC** instruction is executed.

If the branch is taken, a one-byte signed displacement, fetched from the second byte of the instruction, is sign-extended to sixteen bits and added to the program counter. Once the branch address has been calculated, the result is loaded into the program counter, transferring control to that location.

The allowable range of the displacement is – 128 to + 127 (from the instruction immediately following the branch).

**BCC** may be used in several ways: to test the result of a shift into the carry; to determine if the result of a comparison is either *less than* (in which case a branch will be taken), or *greater than or equal* (which causes control to fall through the branch instruction); or to determine if further operations are needed in multi-precision arithmetic.

Because the **BCC** instruction causes a branch to be taken after a comparison or subtraction if the accumulator is less than the memory operand (since the carry flag will always be cleared as a result), many assemblers allow an alternate mnemonic for the **BCC** instruction: **BLT**, or *Branch if Less Than*.

**Flags Affected :**     - - - - -

**Codes:**

<i>Addressing Mode</i> + +	<i>Syntax</i>	<i>Opcode</i> (hex)	<i>Available on:</i>			<i># of</i> <i>Bytes</i>	<i># of</i> <i>Cycles</i>
			6502	65C02	65802/816		
Program Counter Relative	<b>BCC</b> <i>nearlabel</i>  (or <b>BLT</b> <i>nearlabel</i> )	90	x	x	x	2	2 <sup>1,2</sup>

1 Add 1 cycle if branch is taken.

2 Add 1 more cycle if branch taken crosses page boundary on 6502, 65C02, or 65816/65802's 6502 emulation mode (e = 1)

**Branch if Carry Set**

**BCS**

The carry flag in the **P** status register is tested. If it is set, a branch is taken; if it is clear, the instruction immediately following the two-byte **BCS** instruction is executed.

If the branch is taken, a one-byte signed displacement, fetched from the second byte of the instruction, is sign-extended to sixteen bits and added to the program counter. Once the branch address has been calculated, the result is loaded into the program counter, transferring control to that location.

The allowable range of the displacement is – 128 to + 127 (from the instruction immediately following the branch).

**BCS** is used in several ways: to test the result of a shift into the carry; to determine if the result of a comparison is either *greater than or equal* (which causes the branch to be taken) or *less than*; or to determine if further operations are needed in multi-precision arithmetic operations.

Because the **BCS** instruction causes a branch to be taken after a comparison or subtraction if the accumulator is greater than or equal to the memory operand (since the carry flag will always be set as a result), many assemblers allow an alternate mnemonic for the **BCS** instruction: **BGE** or *Branch if Greater or Equal*.

**Flags Affected:**     - - - - -

**Codes:**

<i>Addressing Mode</i>	<i>Syntax</i>	<i>Opcode (hex)</i>	<i>Available on:</i>			<i># of Bytes</i>	<i># of Cycles</i>
			<i>6502</i>	<i>65C02</i>	<i>65802/816</i>		
Program Counter Relative	<b>BCS</b> <i>nearlabel</i> (or <b>BGE</b> <i>nearlabel</i> )	B0	x	x	x	2	2 <sup>1,2</sup>

- 1 Add 1 cycle if branch is taken
- 2 Add 1 more cycle if branch taken crosses page boundary on 6502, 65C02, or 65816/65802's 6502 emulation mode (e = 1).

**Branch if Equal**

**BEQ**

The zero flag in the **P** status register is tested. If it is set, meaning that the last value tested (which affected the zero flag) was zero, a branch is taken; if it is clear, meaning the value tested was non-zero, the instruction immediately following the two-byte **BEQ** instruction is executed.

If the branch is taken, a one-byte signed displacement, fetched from the second byte of the instruction, is sign-extended to sixteen bits and added to the program counter. Once the branch address has been calculated, the result is loaded into the program counter, transferring control to that location.

The allowable range of the displacement is – 128 to + 127 (from the instruction immediately following the branch).

**BEQ** may be used in several ways: to determine if the result of a comparison is zero (the two values compared are equal), for example, or if a value just loaded, pulled, shifted, incremented or decremented is zero; or to determine if further operations are needed in multi-precision arithmetic operations. Because testing for equality to zero does not require a previous comparison with zero, it is generally most efficient for loop counters to count downwards, existing when zero is reached.

**Flags Affected:**        - - - - -

**Codes:**

<i>Addressing Mode</i>	<i>Syntax</i>	<i>Opcode (hex)</i>	<i>Available on:</i>			<i># of Byte s</i>	<i># of Cycle s</i>
			<i>6502</i>	<i>65C02</i>	<i>65802/816</i>		
Program Counter Relative	<b>BEQ</b> <i>nearlabel</i>	F0	x	x	x	2	2 <sup>1,2</sup>

1 Add 1 cycle if branch is taken

2 Add 1 more cycle if branch taken crosses page boundary on 6502, 65C02, or 65816/65802's 6502 emulation mode (e = 1).

**Test Memory Bits against Accumulator**

**BIT**

**BIT** sets the **P** status register flags based on the result of two different operations, making it a dual-purpose instruction:

First, it sets or clears the **n** flag to reflect the value of the high bit of the data located at the effective address specified by the operand, and sets or clears the **v** flag to reflect the contents of the next-to-highest bit of the data addressed.

Second, it logically ANDs the data located at the effective address with the contents of the accumulator; it changes neither value, but sets the **z** flag if the result is zero, or clears it if the result is non-zero.

**BIT** is usually used immediately preceding a conditional branch instruction: to test a memory value's highest or next-to-highest bits; with a mask in the accumulator, to test any bits of the memory operand; or with a constant as the mask (using immediate addressing) or a mask in memory, to test any bits in the accumulator. All of these tests are non-destructive of the data in the accumulator or in memory. When the **BIT** instruction is used with the immediate addressing mode, the **n** and **v** flags are unaffected.

**8-bit accumulator/memory (all processors):** Data in memory is eight-bit; bit 7 is moved into the **n** flag; bit 6 is moved into the **v** flag.

**16-bit accumulator/memory (65802/65816 only, m = 0):** Data in memory is sixteen-bit: the low-order eight bits are located at the effective address; the high-order eight bits are located at the effective address plus one. Bit 15 is moved into the **n** flag; bit 14 is moved into the **v** flag.

**Flags Affected:**     **n v - - - z -** (Other than immediate addressing)  
                           **- - - - - z -** (Immediate addressing only)  
                           **n**     Takes value of most significant bit of memory data.  
                           **v**     Takes value of next-to-highest bit of memory data.  
                           **z**     Set if logical AND of memory and accumulator is zero; else cleared.

**Codes:**

<i>Addressing Mode</i>	<i>Syntax</i>	<i>Opcode (hex)</i>	<i>Available on:</i>			<i># of Bytes</i>	<i># of Cycles</i>
			<i>6502</i>	<i>65C02</i>	<i>65802/816</i>		
Immediate	<b>BIT</b> # <i>const</i>	89		x	x	2*	2 <sup>1</sup>
Absolute	<b>BIT</b> <i>addr</i>	2C	x	x	x	3	4 <sup>1</sup>
Direct Page (DP)	<b>BIT</b> <i>dp</i>	24	x	x	x	2	3 <sup>1,2</sup>
Absolute Indexed, X	<b>BIT</b> <i>addr, X</i>	3C		x	x	3	4 <sup>1,3</sup>
DP Indexed, X	<b>BIT</b> <i>dp, X</i>	34		x	x	2	4 <sup>1,2</sup>

- \* Add 1 byte if m = 0 (16-bit memory/accumulator)
- 1 Add 1 cycle if m = 0 (16-bit memory/accumulator)
- 2 Add 1 cycle if low byte of Direct Page register is other than zero (DL < > 0)
- 3 Add 1 cycle if adding index crosses a page boundary

**Branch if Minus**

**BMI**

The negative flag in the **P** status register is tested. If it is set, the high bit of the value which most recently affected the **n** flag was set, and a branch is taken. A number with its high bit set may be interpreted as a negative two's-complement numbers, so this instruction tests, among other things, for the sign of two's-complement numbers. If the negative flag is clear, the high bit of the value which most recently affected the flag was clear, or, in the two's-complement system, was a positive number, and the instruction immediately following the two-byte **BMI** instruction is executed.

If the branch is taken, a one-byte signed displacement, fetched from the second byte of the instruction, is sign-extended to sixteen bits and added to the program counter. Once the branch address has been calculated, the result is loaded into the program counter, transferring control to that location.

The allowable range of the displacement is – 128 to + 127 (from the instruction immediately following the branch).

**BMI** is primarily used to either determine, in two's-complement arithmetic, if a value is negative or, in logic situations, if the high bit of the value is set. It can also be used when looping down through zero (the loop counter must have a positive initial value) to determine if zero has been passed and to effect an exit from the loop.

**Flags Affected:**     - - - - -

**Codes:**

<i>Addressing Mode</i>	<i>Syntax</i>	<i>Opcode (hex)</i>	<i>Available on:</i>			<i># of Bytes</i>	<i># of Cycle s</i>
			<i>6502</i>	<i>65C02</i>	<i>65802/816</i>		
Program Counter Relative	<b>BMI</b> <i>nearlabel</i>	30	x	x	x	2	2 <sup>1,2</sup>

1 Add 1 cycle if branch is taken.

2 Add 1 more cycle if branch taken crosses page boundary on 6502, 65C02, or 65816/65802's 6502 emulation mode (e = 1)

**Branch if Not Equal**

**BNE**

The zero flag in the **P** status register is tested. If it is clear (meaning the value just tested is non-zero), a branch is taken; if it is set (meaning the value tested is zero), the instruction immediately following the two-byte **BNE** instruction is executed.

If the branch is taken, a one-byte signed displacement, fetched from the second byte of the instruction, is sign-extended to sixteen bits and added to the program counter. Once the branch address has been calculated, the result is loaded into the program counter, transferring control to that location.

The allowable range of the displacement is – 128 to + 127 (from the instruction immediately following the branch).

**BNE** may be used in several ways: to determine if the result of a comparison is non-zero (the two values compared are not equal), for example, or if the value just loaded or pulled from the stack is non-zero, or to determine if further operations are needed in multi-precision arithmetic operations.

**Flags Affected:** - - - - -

**Codes:**

<i>Addressing Mode</i>	<i>Syntax</i>	<i>Opcode (hex)</i>	<i>6502</i>	<i>Available on:</i>			<i># of Bytes</i>	<i># of Cycles</i>
				<i>65C02</i>	<i>65802/816</i>			
Program Relative	Counter <b>BNE</b> <i>nearlabe</i> <i>l</i>	D0	x	x	x	2	2 <sup>1,2</sup>	

1 Add 1 cycle if branch is taken

2 Add 1 more cycle if branch taken crosses page boundary on 6502, 65C02, or 65816/65802's 6502 emulation mode (e = 1)

**Branch if Plus**

**BPL**

The negative flag in the **P** status register is tested. If it is clear – meaning that the last value which affected the zero flag had its high bit clear – a branch is taken. In the two’s complement system, values with their high bit clear are interpreted as positive numbers. If the flag is set, meaning the high bit of the last value was set, the branch is not taken; it is a two’s-complement negative number, and the instruction immediately following the two-byte **BPL** instruction is executed.

If the branch is taken, a one-byte signed displacement, fetched from the second byte of the instruction, is sign-extended to sixteen bits and added to the program counter. Once the branch address has been calculated, the result is loaded into the program counter, transferring control to that location.

The allowable range of the displacement is – 128 to + 127 (from the instruction immediately following the branch).

**BPL** is used primarily to determine, in two’s-complement arithmetic, if a value is positive or not or, in logic situations, if the high bit of the value is clear.

**Flags Affected:**        - - - - -

**Codes:**

<i>Addressing Mode</i>	<i>Syntax</i>	<i>Opcode (hex)</i>	<i>Available on:</i>			<i># of Bytes</i>	<i># of Cycles</i>
			<i>6502</i>	<i>65C02</i>	<i>65802/816</i>		
Program Counter Relative	<b>BPL</b> <i>nearlabel</i>	10	x	x	x	2	2 <sup>1,2</sup>

1 Add 1 cycle if branch is taken

2 Add 1 more cycle if branch taken crosses page boundary on 6502, 65C02, or 65816/65802’s 6502 emulation mode (e = 1)



**Branch Always**

**BRA**

A branch is always taken, and no testing is done: in effect, an unconditional **JMP** is executed, but since signed displacements are used, the instruction is only two bytes, rather than the three bytes of a **JMP**. Additionally, using displacements from the program counter makes the **BRA** instruction relocatable. Unlike a **JMP** instruction, the **BRA** is limited to targets that lie within the range of the one-byte signed displacement of the conditional branches: - 128 to + 127 bytes from the first byte following the **BRA** instruction.

To branch, a one-byte signed displacement, fetched from the second byte of the instruction, is sign-extended to sixteen bits and added to the program counter. Once the branch address has been calculated, the result is loaded into the program counter, transferring control to that location.

**Flags Affected:**     - - - - -

**Codes:**

<i>Addressing Mode</i>	<i>Syntax</i>	<i>Opcode (hex)</i>	<i>Available on:</i>			<i># of Bytes</i>	<i># of Cycles</i>
			<i>6502</i>	<i>65C02</i>	<i>65802/816</i>		
Program Counter	<b>BRA</b>	80		x	x	2	3 <sup>1</sup>
Relative	<i>nearlabel</i>						

1 Add 1 cycle if branch crosses page boundary on 65C02 or in 65816/65802's 6502 emulation mode (e = 1)

## Software Break

## BRK

Force a software interrupt. **BRK** is unaffected by the **i** interrupt disable flag.

Although **BRK** is a one-byte instruction, the program counter (which is pushed onto the stack by the instruction) is incremented by two; this lets you follow the break instruction with a one-byte signature byte indicating which break caused the interrupt. Even if a signature byte is not needed, either the byte following the **BRK** instruction must be padded with some value or the break-handling routine must decrement the return address on the stack to let an **RTI** (return from interrupt) instruction executed correctly.

**6502, 65C02, and Emulation Mode (e = 1):** The program counter is incremented by two, then pushed onto the stack; the status register, with the **b** break flag set, is pushed onto the stack; the interrupt disable flag is set; and the program counter is loaded from the interrupt vector at \$FFFE-FFFF. It is up to the interrupt handling routine at this address to check the **b** flag in the stacked status register to determine if the interrupt was caused by a software interrupt (**BRK**) or by a hardware **IRQ**, which shares **BRK** vector but pushes the status register onto the stack with the **b** break flag clear. For example,

0000	68	PLA		copy status from
0001	48	PHA		top of stack
0002	2910	AND	#\$10	check BRK bit
0004	D007	BNE	ISBRK	branch if set

Fragment 18.1

**65802/65816 Native Mode (e = 0):** The program counter bank register is pushed onto the stack; the program counter is incremented by two and pushed onto the stack; the status register is pushed onto the stack; the interrupt disable flag is set; the program bank register is cleared to zero; and the program counter is loaded from the break vector at \$00FFE6-00FFE7.

**6502:** The **d** decimal flag is not modified after a break is executed.

**65C02 and 65816/65802:** The **d** decimal flag is reset to 0 after a break is executed.

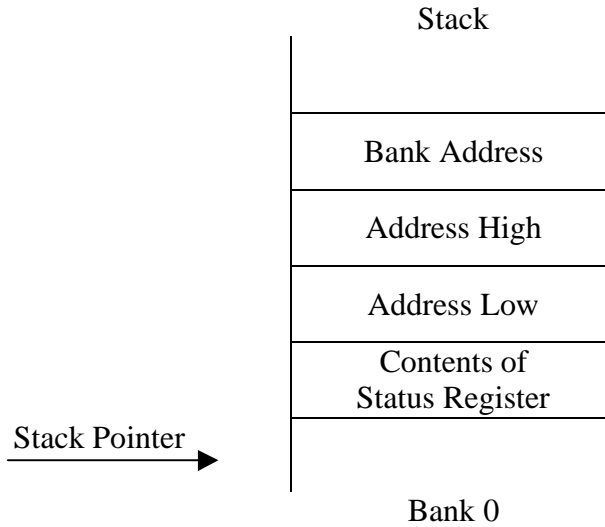

Figure 18-3 65802/65816 Stack After BRK

**Flags Affected:**

- - - **b** - **i** - - (6502)
- - - **b d i** - - (65C02, 65802/65816 emulation mode e = 1)
- - - - **d i** - - (65802/65816 native mode e = 0)

b b in the P register value pushed onto the stack is set.  
d d is reset to 0, for binary arithmetic.  
i The interrupt disable flag is set, disabling hardware IRQ interrupts.

**Codes:**

Addressing Mode	Syntax	Opcode		Available on:			# of Bytes	# of Cycles
		(hex)	6502	65C02	65802/816			
Stack/Interrupt	<b>BRK</b>	00	x	x	x	2*	7 <sup>1</sup>	

\* BRK is 1 byte, but program counter value pushed onto stack is incremented by 2 allowing for optional signature byte.

1 Add 1 cycle for 65802/65816 native mode (e = 0)

**Branch Always Long**

**BRL**

A branch is always taken, similar to the **BRA** instruction. However, **BRL** is a three-byte instruction; the two bytes immediately following the opcode form a *sixteen-bit* signed displacement from the program counter. Once the branch address has been calculated, the result is loaded into the program counter, transferring control to that location.

The allowable range of the displacement is anywhere within the current 64K program bank.

The long branch provides an unconditional transfer of control similar to the **JMP** instruction, with one major advantage: the branch instruction is relocatable while jump instructions are not. However, the (non-relocatable) jump absolute instruction executes one cycle faster.

**Flags Affected:**     - - - - -

**Codes:**

<i>Addressing Mode</i>	<i>Syntax</i>	<i>Opcode (hex)</i>	<i>Available on:</i>			<i># of Bytes</i>	<i># of Cycles</i>
			6502	65C02	65802/816		
Program Counter Relative Long	<b>BRL</b> <i>label</i>	82			x	3	4

**Branch if Overflow Clear**

**BVC**

The overflow flag in the **P** status register is tested. If it is clear, a branch is taken; if it is set, the instruction immediately following the two-byte **BVC** instruction is executed.

If the branch is taken, a one-byte signed displacement, fetched from the second byte of the instruction, is sign-extended to sixteen bits and added to the program counter. Once the branch address has been calculated, the result is loaded into the program counter, transferring control to that location.

The allowable range of the displacement is – 128 to + 127 (from the instruction immediately following the branch).

The overflow flag is altered by only four instructions on the 6502 and 65C02 – addition, subtraction, the **CLV** clear-the-flag instruction, and the **BIT** bit-testing instruction. In addition, all the flags are restored from the stack by the **PLP** and **RTI** instructions. On the 65802/65816, however, the **SEP** and **REP** instructions can also modify the **v** flag.

**BVC** is used almost exclusively to check that a two’s-complement arithmetic calculation has not overflowed, much as the carry is used to determine if an unsigned arithmetic calculation has overflowed. (Note, however, that the compare instructions do not affect the overflow flag.) You can also use **BVC** to test the second – highest bit in a value by using it after the **BIT** instruction, which moves the second – highest bit of the tested value into the **v** flag.

The overflow flag can also be set by the Set Overflow hardware signal on the 6502, 65C02, and 65802; on many systems, however, there is no connection to this pin.

**Flags Affected:**     - - - - -

**Codes:**

<i>Addressing Mode</i>	<i>Syntax</i>	<i>Opcode (hex)</i>	<i>Available on:</i>			<i># of Bytes</i>	<i># of Cycles</i>
			<i>6502</i>	<i>65C02</i>	<i>65802/816</i>		
Program Counter	<b>BVC</b>	50	x	x	x	2	2 <sup>1,2</sup>
Relative	<i>nearlabel</i>						

1 Add 1 cycle if branch is taken

2 Add 1 more cycle if branch taken crosses page boundary on 6502, 65C02, or 65816/65802’s 6502 emulation mode (e = 1)

**Branch if Overflow Set**

**BVS**

The overflow flag in the **P** status register is tested. If it is set, a branch is taken; if it is clear, the instruction immediately following the two-byte **BVS** instruction is executed.

If the branch is taken, a one-byte signed displacement, fetched from the second byte of the instruction, is sign-extended to sixteen bits and added to the program counter. Once the branch address has been calculated, the result is loaded into the program counter, transferring control to that location.

The allowable range of the displacement is – 128 to + 127 (from the instruction immediately following the branch).

The overflow flag is altered by only four instructions on the 6502 and 65C02 – addition, subtraction, the **CLV** clear-the-flag instruction and the **BIT** bit-testing instructions. In addition, all the flags are restored from the stack by the **PLP** and **RTI** instruction. On the 65802/65816, the **SEP** and **REP** instructions can also modify the **v** flag.

**BVS** is used almost exclusively to determine if a two’s-complement arithmetic calculation has overflowed, much as the carry is used to determine if an unsigned arithmetic calculation has overflowed. (Note, however, that the compare instructions do not affect the overflow flag.) You can also use **BVS** to test the second-highest bit in a value by using it after the **BLT** instruction, which moves the second-highest bit of the tested value into the **v** flag.

The overflow flag can also be set by the Set Overflow hardware signal on the 6502, 65C02, and 65802; on many systems, however, there is no hardware connection to this signal.

**Flags Affected:** - - - - -

**Codes:**

<i>Addressing Mode</i>	<i>Syntax</i>	<i>Opcode (hex)</i>	<i>Available on:</i>			<i># of Bytes</i>	<i># of Cycles</i>
			<i>6502</i>	<i>65C02</i>	<i>65802/816</i>		
Program Counter Relative	<b>BVS</b> <i>nearlabel</i>	70	x	x	x	2	2 <sup>1,2</sup>

1 <sub>1</sub> Add 1 cycle if branch is taken

2 Add 1 more cycle if branch taken crosses page boundary on 6502, 65C02, or 65816/65802’s 6502 emulation mode (e = 1)

**Clear Carry Flag**

**CLC**

Clear the carry flag in the status register.

**CLC** is used prior to addition (using the 65x's **ADC** instruction) to keep the carry flag from affecting the result; prior to a **BCC** (branch on carry clear) instruction on the 6502 to force a branch-always; and prior to an **XCE** (exchange carry flag with emulation bit) instruction to put the 65802 or 65816 into native mode.

**Flags Affected:**     - - - - - c  
                           c   carry flag cleared always.

**Codes:**

<i>Addressing Mode</i>	<i>Syntax</i>	<i>Opcode</i>	<i>Available on:</i>			<i># of</i>	<i># of</i>
		<i>(hex)</i>	<i>6502</i>	<i>65C02</i>	<i>65802/816</i>	<i>Bytes</i>	<i>Cycles</i>
Implied	<b>CLC</b>	18	x	x	x	1	2

**Clear Decimal Mode Flag**

**CLD**

Clear the decimal mode flag in the status register.

**CLD** is used to shift 65x processors back into binary mode from decimal mode, so that the **ADC** and **SBC** instructions will correctly operate on binary rather than BCD data.

**Flags Affected:**     - - - - **d** - - -

    d   decimal mode flag cleared always.

**Codes:**

<i>Addressing Mode</i>	<i>Syntax</i>	<i>Opcode</i>		<i>Available on:</i>			<i># of</i>	<i># of</i>
		<i>(hex)</i>	<i>6502</i>	<i>65C02</i>	<i>65802/816</i>	<i>Bytes</i>	<i>Cycles</i>	
Implied	<b>CLD</b>	D8	x	x	x	1	2	



**Clear Interrupt Disable Flag**

**CLI**

Clear the interrupt disable flag in the status register.

**CLI** is used to re-enable hardware interrupt (IRQ) processing. (When the **i** bit is set, hardware interrupts are ignored.) The processor itself sets the **i** flag when it begins servicing an interrupt, so interrupt handling routines must re-enable interrupts with **CLI** if the interrupt-service routine is designed to service interrupts that occur while a previous interrupt is still being handled; otherwise, the **RTI** instruction will restore a clear **i** flag from the stack, and **CLI** is not necessary. **CLI** is also used to re-enable interrupts if they have been disabled during execution of time-critical or other code which cannot be interrupted.

**Flags Affected:**     - - - - - **i** - -  
                           i interrupt disable flag cleared always.

**Codes:**

<i>Addressing Mode</i>	<i>Syntax</i>	<i>Opcode</i>		<i>Available on:</i>			<i># of</i>	<i># of</i>
		<i>(hex)</i>	<i>6502</i>	<i>65C02</i>	<i>65802/816</i>	<i>Bytes</i>	<i>Cycles</i>	
Implied	<b>CLI</b>	58	x	x	x	1	2	

**Clear Overflow Flag**

**CLV**

Clear the overflow flag in the status register.

**CLV** is sometimes used prior to a **BVC** (branch on overflow clear) to force a branch-always on the 6502. Unlike the other clear flag instructions, there is no complementary “set flag” instruction to set the overflow flag, although the overflow flag can be set by hardware via the Set Overflow input pin on the processor. This signal, however, is often unconnected. The 65802/65816 **REP** instruction can, of course, clear the overflow flag; on the 6502 and 65C02, a **BIT** instruction with a mask in memory that has bit 6 set can be used to set the overflow flag.

**Flags Affected:**     - v - - - - -  
                           v overflow flag cleared always.

**Codes:**

<i>Addressing Mode</i>	<i>Syntax</i>	<i>Opcode (hex)</i>	<i>Available on:</i>			<i># of Bytes</i>	<i># of Cycles</i>
			<i>6502</i>	<i>65C02</i>	<i>65802/816</i>		
Implied	<b>CLV</b>	B8	x	x	x	1	2

## Compare Accumulator with Memory

## CMP

Subtract the data located at the effective address specified by the operand from the contents of the accumulator, setting the carry, zero, and negative flags based on the result, but without altering the contents of either the memory location or the accumulator. That is, the result is not saved. The comparison is of unsigned binary values only.

The **CMP** instruction differs from the **SBC** instruction in several ways. First, the result is not saved. Second, the value in the carry prior to the operation is irrelevant to the operation; that is, the carry does not have to be set prior to a compare as it is with 65x subtractions. Third, the compare instruction does not set the overflow flag, so it cannot be used for signed comparisons. Although decimal mode does not affect the **CMP** instruction, decimal comparisons are effective, since the equivalent binary values maintain the same magnitude relationships as the decimal values have, for example, \$99 > \$04 just as 99 > 4.

The primary use for the compare instruction is to set the flags so that a conditional branch can then be executed.

**8-bit accumulator (all processors):** Data compared is eight-bit.

**16-bit accumulator (65802/65816 only, m = 0):** Data compared is sixteen-bit: the low-order eight bits of the data in memory are located at the effective address; the high-order eight bits are located at the effective address plus one.

### Flags Affective:

**n** — — — — **z** **c**

**n** Set if most significant bit of result is set; else cleared.

**z** Set if result is zero; else cleared.

**c** Set if no borrow required (accumulator value higher or same);  
cleared if borrow required (accumulator value lower).

## The Western Design Center

### Codes:

Addressing Mode + +	Syntax	Opcode (hex)	Available on:			# of Bytes	# of Cycles
			6502	65C02	65802/816		
Immediate	<b>CMP</b> #const	C9	x	x	x	2*	2 <sup>1</sup>
Absolute	<b>CMP</b> addr	CD	x	x	x	3	4 <sup>1</sup>
Absolute Long	<b>CMP</b> long	CF			x	4	5 <sup>1</sup>
Direct Page (also DP)	<b>CMP</b> dp	C5	x	x	x	2	3 <sup>1,2</sup>
DP Indirect	<b>CMP</b> (dp)	D2		x	x	2	5 <sup>1,2</sup>
DP Indirect Long	<b>CMP</b> [dp]	C7			x	2	6 <sup>1,2</sup>
Absolute Indexed, X	<b>CMP</b> addr, X	DD	x	x	x	3	4 <sup>1,3</sup>
Absolute Long Indexed, X	<b>CMP</b> long, X	DF			x	4	5 <sup>1</sup>
Absolute Indexed, Y	<b>CMP</b> addr, Y	D9	x	x	x	3	4 <sup>1,3</sup>
DP Indexed, X	<b>CMP</b> dp, X	D5	x	x	x	2	4 <sup>1,2</sup>
DP Indexed Indirect, X	<b>CMP</b> (dp, X)	C1	x	x	x	2	6 <sup>1,2</sup>
DP Indirect Indexed, Y	<b>CMP</b> (dp), Y	D1	x	x	x	2	5 <sup>1,2,3</sup>
DP Indirect Long Indexed, Y	<b>CMP</b> [dp], Y	D7			x	2	6 <sup>1,2</sup>
Stack Relative (also SR)	<b>CMP</b> sr, S	C3			x	2	4 <sup>1</sup>
SR Indirect Indexed, Y	<b>CMP</b> (sr, S), Y	D3			x	2	7 <sup>1</sup>

+ + CMP, a Primary Group Instruction, has available all of the Primary Group addressing modes and bit patterns

\* Add 1 byte if m = 0 (16-bit memory/accumulator)

<sup>1</sup> Add 1 cycle if m = 0 (16-bit memory/accumulator)

<sup>2</sup> Add 1 cycle if low byte of Direct Page register is other than zero (DL < > 0)

<sup>3</sup> Add 1 cycle if adding index crosses a page boundary

Co-Processor Enable

COP

Execution of **COP** causes a software interrupt, similarly to **BRK**, but through the separate **COP** vector. Alternatively, **COP** may be trapped by a co-processor, such as a floating point or graphics processor, to call a co-processor function. **COP** is unaffected by the **i** interrupt disable flag.

**COP** is much like **BRK**, with the program counter value pushed on the stack being incremented by two; this lets you follow the co-processor instruction with a signature byte to indicate to the co-processor or co-processor handling routine which operation to execute. Unlike the **BRK** instruction, 65816 assemblers require you to follow the **COP** instruction with such a signature byte. Signature bytes in the range \$80-\$FF are reserved by the Western Design Center for implementation of co-processor control; signatures in the range \$00-\$7F are available for use with software-implemented **COP** handlers.

**6502 Emulation Mode (65802/65816, e=1):** The program counter is incremented by two and pushed onto the stack; the status register is pushed onto the stack; the interrupt disable flag is set; and the program counter is loaded from the emulation mode co-processor vector at \$FFF4-FFF5. The **d** decimal flag is cleared after a **COP** is executed.

**65802/65816 Native Mode (e = 0):** The program counter bank register is pushed onto the stack; the program counter is incremented by two and pushed onto the stack; the status register is pushed onto the stack; the interrupt disable flag is set; the program bank register is cleared to zero; and the program counter is loaded from the native mode co-processor vector at \$0FFE4-0FFE5. The **d** decimal flag is reset to 0 after a **COP** is executed.

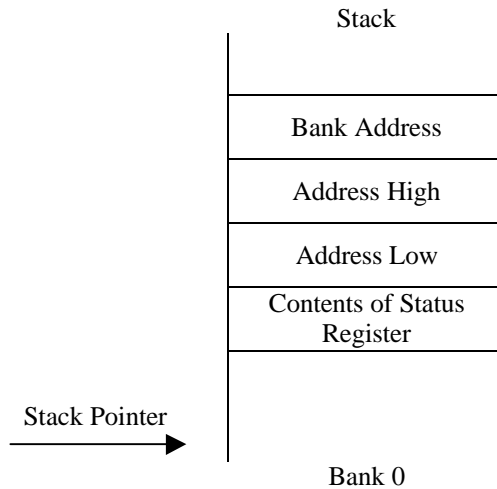

Figure 18-4 Stack after COP

Flag Affected:

- - - - **d i** - -

d d is rest to 0.

i The interrupt disable flag is set, disabling hardware interrupts.

Codes:

Addressing mode	Syntax	Opcode		Available on:			# of Bytes	# of Cycles
		(hex)	6502	65C02	65802/816	x		
Stack/Interrupt	<b>COP</b> const	02				x	2*	7 <sup>1</sup>

\* COP is 1 byte, but program counter value pushed onto stack is incremented by 2 allowing for optional code byte

1 Add 1 cycle for 65816/65802 native mode (e = 0)

**Compare Index Register X with Memory****CPX**

Subtract the data located at the effective address specified by the operand from the contents of the **X** register, setting the carry, zero, and negative flags based on the result, but without altering the contents of either the memory location or the register. The result is not saved. The comparison is of unsigned values only (except for signed comparison for equality).

The primary use for the **CPX** instruction is to test the value of the **X** index register against loop boundaries, setting the flags so that a conditional branch can be executed.

**8-bit index registers (all processors):** Data compared is eight-bit.

**16-bit index registers (65802/65816 only, x = 0):** Data compared is sixteen-bit: the low-order eight bits of the data in memory are located at the effective address; the high-order eight bits are located at the effective address plus one.

**Flags Affected:**     **n - - - - z c**  
 n     Set if most significant bit of result is set; else cleared.  
 z     Set if result is zero; else cleared.  
 c     Set if no borrow required (**X** register value higher or same);  
       cleared if borrow required (**X** register value lower).

**Codes:**

<i>Addressing Mode</i>	<i>Syntax</i>	<i>Opcode (hex)</i>	<i>Available on:</i>			<i># of Bytes</i>	<i># of Cycles</i>
			<i>6502</i>	<i>65C02</i>	<i>65802/816</i>		
Immediate	CPX <i>#const</i>	E0	x	x	x	2*	2 <sup>1</sup>
Absolute	CPX <i>addr</i>	EC	x	x	x	3	4 <sup>1</sup>
Direct Page (also DP)	CPX <i>dp</i>	E4	x	x	x	2	3 <sup>1,2</sup>

\* Add 1 byte if x = 0 (16-bit index registers)

1 Add 1 cycle if x = 0 (16-bit index registers)

2 Add 1 cycle if low byte of Direct Page register is other than zero (DL < > 0)

**Compare Index Register Y with Memory CPY**

**CPY**

Subtract the data located at the effective address specified by the operand from the contents of the **Y** register, setting the carry, zero, and negative flags based on the result, but without altering the contents of either the memory location or the register. The comparison is of unsigned values only (expect for signed comparison for equality).

The primary use for the **CPY** instruction is to test the value of the **Y** index register against loop boundaries, setting the flags so that a conditional branch can be executed.

**8-bit index registers (all processors):** Data compared is eight-bit.

**16-bit index registers (65802/65816 only, x = 0):** Data compared is sixteen-bit: the low-order eight bits of the data in memory is located at the effective address; the high-order eight bits are located at the effective address plus one.

**Flags Affected:**

**n - - - - z c**

n Set if most significant bit of result is set; else cleared.

z Set if result is zero; else cleared.

c Set if no borrow required (Y register value higher or same); cleared if borrow required (Y register value lower).

**Codes:**

<i>Addressing Mode</i> + +	<i>Syntax</i>	<i>Opcode</i> (hex)	<i>Available on:</i>			<i># of</i> <i>Bytes</i>	<i># of</i> <i>Cycles</i>
			6502	65C02	65802/816		
Immediate	CPY # const	C0	x	x	x	2*	2 <sup>1</sup>
Absolute	CPY addr	CC	x	x	x	3	4 <sup>1</sup>
Direct Page (also DP)	CPY dp	C4	x	x	x	2	3 <sup>1,2</sup>

\* Add 1 byte if x = 0 (16-bit index registers)

1 Add 1 cycle if x = 0 (16-bit index registers)

2 Add 1 cycle if low byte of Direct Page register is other than zero (DL<>0)

**Decrement****DEC**

Decrement by one the contents of the location specified by the operand (subtract one from the value).

Unlike subtracting a one using the **SBC** instruction, the decrement instruction is neither affected by nor affected the carry flag. You can test for wraparound only by testing after every decrement to see if the value is zero or negative. On the other hand, you don't need to set the carry before decrementing.

**DEC** is unaffected by the setting of the **d** (decimal) flag.

**8-bit accumulator/memory (all processors):** Data decremented is eight-bit.

**16-bit accumulator/memory (65802/65816 only, m = 0):** Data Decrement is sixteen-bit: if in memory, the low-order eight bits are located at the effective address; the high-order eight bits are located at the effective address plus one.

**Flags Affected:**     **n - - - - z -**

n Set if most significant bit of result is set; else cleared.

z Set if result is zero; else cleared.

**Codes:**

<i>Addressing Mode</i>	<i>Syntax</i>	<i>Opcode (hex)</i>	<i>Available on:</i>			<i># of Bytes</i>	<i># of Cycles</i>
			<i>6502</i>	<i>65C02</i>	<i>65802/816</i>		
Accumulator	<b>DEC A</b>	3A		x	x	1	2
Absolute	<b>DEC addr</b>	CE	x	x	x	3	6 <sup>1</sup>
Direct Page (also DP)	<b>DEC dp</b>	C6	x	x	x	2	5 <sup>1,2</sup>
Absolute Indexed, X	<b>DEC addr, X</b>	DE	x	x	x	3	7 <sup>1,3</sup>
DP Indexed, X	<b>DEC dp, X</b>	D6	x	x	x	2	6 <sup>1,2</sup>

1 Add 2 cycles if m = 0 (16-bit memory/accumulator)

2 Add 1 cycle if low byte of Direct Page register is other than zero (DL<>0)

3 Subtract 1 cycle if 65C02 and no page boundary crossed



**Decrement Index Register X**

**DEX**

Decrement by one the contents of index register **X** (subtract one from the value). This is a special purpose, implied addressing form of the **DEC** instruction.

Unlike using **SBC** to subtract a one from the value, the **DEX** instruction does not affect the carry flag; you can test for wraparound only by testing after every decrement to see if the value is zero or negative. On the other hand, you don't need to set carry before decrementing.

**DEX** is unaffected by the setting of the **d** (decimal) flag.

**8-bit index registers (all processors):** Data decremented is eight-bit.

**16-bit index registers (65802/65816 only, x = 0):** Data decremented is sixteen-bit.

**Flags Affected:**

**n** - - - - **z** -

**n** Set if most significant bit of result is set; else cleared.

**z** Set if result is zero; else cleared.

**Codes:**

<i>Addressing Mode</i>	<i>Syntax</i>	<i>Opcode</i>	<i>Available on:</i>			<i># of</i>	<i># of</i>
		<i>(hex)</i>	<i>6502</i>	<i>65C02</i>	<i>65802/816</i>	<i>Bytes</i>	<i>Cycles</i>
Implied	DEX	CA	x	x	x	1	2

**Decrement Index Register Y**

**DEY**

Decrement by one the contents of index register **Y** (subtract one from the value). This is a special purpose, implied addressing form of the **DEC** instruction.

Unlike using **SBC** to subtract a one from the value, the **DEY** instruction does not affect the carry flag; you can test for wraparound only by testing after every decrement to see if the value is zero or negative. On the other hand, you don't need to set the carry before decrementing.

**DEY** is unaffected by the setting of the **d** (decimal) flag.

**8-bit index registers (all processors):** Data decremented is eight-bit.

**16-bit index registers (65802/65816 only, x = 0):** Data decremented is sixteen-bit.

**Flags Affected:**      **n - - - - z -**

n Set if most significant bit of result is set; else cleared.

z Set if result is zero; else clear.

**Codes:**

<i>Addressing Mode</i>	<i>Syntax</i>	<i>Opcode</i>	<i>Available on:</i>			<i># of</i>	<i># of</i>
		<i>(hex)</i>	<i>6502</i>	<i>65C02</i>	<i>65802/816</i>	<i>Bytes</i>	<i>Cycles</i>
Implied	DEY	88	x	x	x	1	2

**Exclusive-OR Accumulator with Memory**

**EOR**

Bitwise logical Exclusive-OR the data located at the effective address specified by the operand with the contents of the accumulator. Each bit in the accumulator is exclusive-ORed with the corresponding bit in memory, and the result is stored into the same accumulator bit.

The truth table for the logical exclusive-OR operation is:

		<i>Second Operand</i>	
		0	1
<i>First Operand</i>	0	0	1
	1	1	0

**Figure 18-5**Exclusive OR Truth Table

A 1 or logical true results only if the two elements of the Exclusive-OR operation are *different*.

**8-bit accumulator (all processors):** Data exclusive-ORed from memory is eight-bit.

**16-bit accumulator (65802/65816 only, m = 0):** Data exclusive-ORed from memory is sixteen-bit: the low-order eight bits are located at the effective address; the high-order eight bits are located at the effective address plus one.

**Flags Affected:**

**n** - - - - **z** -

n Set if most significant bit of result is set; else cleared.

z Set if result is zero; else cleared.

## The Western Design Center

### Codes:

Addressing Mode	Syntax	Opcode (hex)	Available on:			# of Byte s	# of Cycle s
			6502	65C02	65802/816		
Immediate	<b>EOR</b> # <i>const</i>	49	x	x	x	2*	2 <sup>1</sup>
Absolute	<b>EOR</b> <i>addr</i>	4D	x	x	x	3	4 <sup>1</sup>
Absolute Long	<b>EOR</b> <i>long</i>	4F			x	4	5 <sup>1</sup>
Direct Page (also DP)	<b>EOR</b> <i>dp</i>	45	x	x	x	2	3 <sup>1,2</sup>
DP Indirect	<b>EOR</b> ( <i>dp</i> )	52		x	x	2	5 <sup>1,2</sup>
DP Indirect Long	<b>EOR</b> [ <i>dp</i> ]	47			x	2	6 <sup>1,2</sup>
Absolute Indexed, X	<b>EOR</b> <i>addr</i> , X	5D	x	x	x	3	4 <sup>1,3</sup>
Absolute Long Indexed, X	<b>EOR</b> <i>long</i> , X	5F			x	4	5 <sup>1</sup>
Absolute Indexed, Y	<b>EOR</b> <i>addr</i> , Y	59	x	x	x	3	4 <sup>1,3</sup>
DP Indexed, X	<b>EOR</b> <i>dp</i> , X	55	x	x	x	2	4 <sup>1,2</sup>
DP Indexed Indirect, X	<b>EOR</b> ( <i>dp</i> , X)	41	x	x	x	2	6 <sup>1,2</sup>
DP Indirect Indexed, Y	<b>EOR</b> ( <i>dp</i> ), Y	51	x	x	x	2	5 <sup>1,2,3</sup>
DP Indirect Long Indexed, Y	<b>EOR</b> [ <i>dp</i> ], Y	57			x	2	6 <sup>1,2</sup>
Stack Relative (also SR)	<b>EOR</b> <i>sr</i> , S	43			x	2	4 <sup>1</sup>
SR Indirect Indexed, Y	<b>EOR</b> ( <i>sr</i> , S), Y	53			x	2	7 <sup>1</sup>

++ EOR, a Primary Group Instruction, has available all of the Primary Group addressing modes and bit patterns

\* Add 1 byte if m = 0 (16-bit memory/accumulator)

1 Add 1 cycle if m = 0 (16-bit memory/accumulator)

2 Add 1 cycle if low byte of Direct Page register is other than zero (DL<>0)

3 Add 1 cycle if adding index crosses a page boundary

**Increment**

**INC**

Increment by one the contents of the location specified by the operand (add one to the value).

Unlike adding a one with the **ADC** instruction, however, the increment instruction is neither affected by nor affects the carry flag. You can test for wraparound only by testing after every increment to see if the result is zero or positive. On the other hand, you don't have to clear the carry before incrementing.

The **INC** instruction is unaffected by the **d** (decimal) flag.

**8-bit accumulator/memory (all processors):** Data incremented is eight-bit.

**16-bit accumulator/memory (65802/65816 only, m=0):** Data incremented is sixteen-bit: if in memory, the low-order eight bits are located at the effective address; the high-order eight-bits are located at the effective address plus one.

**Flags Affected:**

**n - - - - z -**

n Set if most significant bit of result is set; else cleared.

z Set if result is zero; else cleared.

**Codes:**

<i>Addressing Mode</i>	<i>Syntax</i>	<i>Opcode (hex)</i>	<i>Available on:</i>			<i># of Bytes</i>	<i># of Cycles</i>
			<i>6502</i>	<i>65C02</i>	<i>65802/816</i>		
Accumulator	<b>INC A</b>	1A		x	x	1	2
Absolute	<b>INC addr</b>	EE	x	x	x	3	6 <sup>1</sup>
Direct Page (also DP)	<b>INC dp</b>	E6	x	x	x	2	5 <sup>1,2</sup>
Absolute Indexed, X	<b>INC addr, X</b>	FE	x	x	x	3	7 <sup>1,3</sup>
DP Indexed, X	<b>INC dp, X</b>	F6	x	x	x	2	6 <sup>1,2</sup>

1 Add 2 cycles if m = 0 (16-bit memory/accumulator)

2 Add 1 cycle if low byte of Direct Page register is other than zero (DL<>0)

3 Subtract 1 cycle if 65C02 and no page boundary crossed

**Increment Index Register X**

**INX**

Increment by one the contents of index register **X** (add one to the value). This is a special purpose, implied addressing form of the **INC** instruction.

Unlike using **ADC** to add a one to the value, the **INX** instruction does not affect the carry flag. You can execute it without first clearing the carry. But you can test for wraparound only by testing after every increment to see if the result is zero or positive. The **INX** instruction is unaffected by the **d** (decimal) flag.

**8-bit index registers (all processors):** Data incremented is eight-bit.

**16-bit index registers (65802/65816 only, x = 0):** Data incremented is sixteen-bit.

**Flags Affected:**

**n** - - - - - **z** -

**n** Set if most significant bit of result is set; else cleared.

**z** Set if result is zero; else cleared.

**Codes:**

<i>Addressing Mode</i>	<i>Syntax</i>	<i>Opcode</i>		<i>Available on:</i>			<i># of</i>	<i># of</i>
		<i>(hex)</i>	<i>6502</i>	<i>65C02</i>	<i>65802/816</i>	<i>Bytes</i>	<i>Cycles</i>	
Implied	<b>INX</b>	E8	x	x	x	1	2	

**Increment Index Register Y**

**INY**

Increment by one the contents of index register **Y** (add one to the value). This is a special purpose, implied addressing form of the **INC** instruction.

Unlike using **ADC** to add one to the value, the **INY** instruction does not affect the carry flag. You can execute it without first clearing the carry. But you can test for wraparound only by testing after every increment to see if the value is zero or positive. The **INY** instruction is unaffected by the **d** (decimal) flag.

**8-bit index registers (all processors):** Data incremented is eight-bit.

**16-bit index registers (65802/65816 only, x = 0):** Data incremented is sixteen-bit.

**Flags Affected:**

**n - - - - z -**

n Set if most significant bit of result is set; else cleared.

z Set if result is zero; else cleared.

**Codes:**

<i>Addressing Mode</i>	<i>Syntax</i>	<i>Opcode</i>		<i>Available on:</i>			<i># of</i>	<i># of</i>
		<i>(hex)</i>	<i>6502</i>	<i>65C02</i>	<i>65802/816</i>	<i>Bytes</i>	<i>Cycles</i>	
Implied	<b>INY</b>	C8	x	x	x	1	2	

**Jump**

**JMP**

Transfer control to the address specified by the operand field.

The program counter is loaded with the target address. If a long **JMP** is executed, the program counter bank is loaded from the third byte of the target address specified by the operand.

**Flags Affected:**     - - - - -

**Codes:**

Addressing Mode + +	Syntax	Opcode	Available on:			# of	# of
		(hex)	6502	65C02	65802/816	Bytes	Cycles
Absolute	<b>JMP</b> <i>addr</i>	4C	x	x	x	3	3
Absolute Indirect	<b>JMP</b> ( <i>addr</i> )	6C	x	x	x	3	5 <sup>1,2</sup>
Absolute Indexed Indirect	<b>JMP</b> ( <i>addr</i> , <i>X</i> )	7C		x	x	3	6
Absolute Long	<b>JMP</b> <i>long</i> (or <b>JML</b> <i>long</i> )	5C			x	4	4
Absolute Indirect Long	<b>JMP</b> [ <i>addr</i> ] (or <b>JML</b> [ <i>addr</i> ])	DC			x	3	6

1    1 Add 1 cycle if 65C02

2    6502: If low byte of *addr* is \$FF (i.e., *addr* is \$xxFF): yields incorrect result



**Jump to Subroutine Long (Inter-Bank)**

**JSL**

Jump-to-subroutine with long (24-bit) addressing: transfer control to the subroutine at the 24-bit address which is the operand, after first pushing a 24-bit (long) return address onto the stack. This return address is the address of the last instruction byte (the fourth instruction byte, or the third operand byte), *not* the address of the next instruction; it is the return address minus one.

The current program counter bank is pushed onto the stack first, then the high-order byte of the return address and then the low-order byte of the address are pushed on the stack in standard 65x order (low byte in the lowest address, bank byte in the highest address). The stack pointer is adjusted after each byte is pushed to point to the next lower byte (the next available stack location). The program counter bank register and program counter are then loaded with the operand values, and control is transferred to the specified location.

**Flags Affected:**     - - - - -

**Codes:**

<i>Addressing Mode</i>	<i>Syntax</i>	<i>Opcode</i>	<i>Available on:</i>			<i># of</i>	<i># of</i>
		<i>(hex)</i>	<i>6502</i>	<i>65C02</i>	<i>65802/816</i>	<i>Bytes</i>	<i>Cycles</i>
Absolute Long	<b>JSL long</b> (or <b>JSR long</b> )	22			x	4	8

**Jump to Subroutine**

**JSR**

Transfer control to the subroutine at the location specified by the operand, after first pushing onto the stack, as a return address, the current program counter value, that is, the address of the last instruction byte (the third byte of a three-byte instruction, the fourth byte of a four-byte instruction), *not* the address of the next instruction.

If an absolute operand is coded and is less than or equal to \$FFFF, absolute addressing is assumed by the assembler; if the value is greater than \$FFFF, absolute long addressing is used.

If long addressing is used, the current program counter bank is pushed onto the stack first. Next – or first in the more normal case of intra-bank addressing – the high order byte of the return address is pushed, followed by the low order byte. This leaves it on the stack in standard 65x order (lowest byte at the lowest address, highest byte at the highest address). After the return address is pushed, the stack pointer points to the next available location (next lower byte) on the stack. Finally, the program counter (and, in the case of long addressing, the program counter bank register) is loaded with the values specified by the operand, and control is transferred to the target location.

**Flags Affected:**     - - - - -

**Codes:**

<i>Addressing Mode</i>	<i>Syntax</i>	<i>Opcode (hex)</i>	<i>Available on:</i>			<i># of Bytes</i>	<i># of Cycles</i>
			<i>6502</i>	<i>65C02</i>	<i>65802/816</i>		
Absolute	<b>JSR</b> <i>addr</i>	20	x	x	x	3	6
Absolute Indexed Indirect	<b>JSR</b> ( <i>addr</i> , <i>X</i> )	FC			x	3	8
Absolute Long	<b>JSR</b> <i>long</i> (or <b>JSL</b> <i>long</i> )	22			x	4	8

## Load Accumulator from Memory

**LDA**

Load the accumulator with the data located at the effective address specified by the operand.

**8-bit accumulator (all processors):** Data is eight-bit

**16-bit accumulator (65802/65816 only, m = 0):** Data is sixteen-bit; the low-order eight bits are located at the effective address; the high-order eight bits are located at the effective address plus one.

**Flags Affected:**     **n - - - - z -**

n Set if most significant bit of loaded value is set; else cleared.

z Set if value loaded is zero; else cleared.

### Codes:

Addressing Mode + +	Syntax	Opcode (hex)	Available on:			# of Bytes	# of Cycles
			6502	65C02	65802/816		
Immediate	<b>LDA</b> # <i>const</i>	A9	x	x	x	2*	2 <sup>1</sup>
Absolute	<b>LDA</b> <i>addr</i>	AD	x	x	x	3	4 <sup>1</sup>
Absolute Long	<b>LDA</b> <i>long</i>	AF			x	4	5 <sup>1</sup>
Direct Page (DP)	<b>LDA</b> <i>dp</i>	A5	x	x	x	2	3 <sup>1,2</sup>
DP Indirect	<b>LDA</b> ( <i>dp</i> )	B2		x	x	2	5 <sup>1,2</sup>
DP Indirect Long	<b>LDA</b> [ <i>dp</i> ]	A7			x	2	6 <sup>1,2</sup>
Absolute Indexed, X	<b>LDA</b> <i>addr</i> , <i>X</i>	BD	x	x	x	3	4 <sup>1,3</sup>
Absolute Long Indexed, X	<b>LDA</b> <i>long</i> , <i>X</i>	BF			x	4	5 <sup>1</sup>
Absolute Indexed, Y	<b>LDA</b> <i>addr</i> , <i>Y</i>	B9	x	x	x	3	4 <sup>1,3</sup>
DP Indexed, X	<b>LDA</b> <i>dp</i> , <i>X</i>	B5	x	x	x	2	4 <sup>1,2</sup>
DP Indexed Indirect, X	<b>LDA</b> ( <i>dp</i> , <i>X</i> )	A1	x	x	x	2	6 <sup>1,2</sup>
DP Indirect Indexed, Y	<b>LDA</b> ( <i>dp</i> ), <i>Y</i>	B1	x	x	x	2	5 <sup>1,2,3</sup>
DP Indirect Long Indexed, Y	<b>LDA</b> [ <i>dp</i> ], <i>Y</i>	B7			x	2	6 <sup>1,2</sup>
Stack Relative (also SR)	<b>LDA</b> <i>sr</i> , <i>S</i>	A3			x	2	4 <sup>1</sup>
SR Indirect Indexed, Y	<b>LDA</b> ( <i>sr</i> , <i>S</i> ), <i>Y</i>	B3			x	2	7 <sup>1</sup>

+ + LDA, a Primary Group Instruction, has available all of the Primary Group addressing modes and bit patterns

\* Add 1 byte if m = 0 (16-bit memory/accumulator)

1 Add 1 cycle if m = 0 (16-bit memory/accumulator)

2 Add 1 cycle if low byte of Direct Page register is other than zero (DL < > 0)

3 Add 1 cycle if adding index crosses a page boundary

**Load Index Register X from Memory**

**LDX**

Load index register **X** with the data located at the effective address specific by the operand.

**8-bit index registers (all processors):** Data is eight-bit.

**16-bit index registers (65802/65816 only, x = 0):** Data is sixteen-bit: the low-order eight bits are located at the effective address; the high-order eight bits are located at the effective address plus one.

**Flags Affected:**      **n - - - - z -**

**n**      **Set if most significant bit of loaded value is set; else cleared.**

**z**      **Set if value loaded is zero; else cleared.**

**Codes:**

<i>Addressing Mode</i>	<i>Syntax</i>	<i>Opcode (hex)</i>	<i>Available on:</i>			<i># of Bytes</i>	<i># of Cycles</i>
			<i>6502</i>	<i>65C02</i>	<i>65802/816</i>		
Immediate	<b>LDX # const</b>	A2	x	x	x	2*	2 <sup>1</sup>
Absolute	<b>LDX addr</b>	AE	x	x	x	3	4 <sup>1</sup>
Direct Page (also DP)	<b>LDX dp</b>	A6	x	x	x	2	3 <sup>1,2</sup>
Absolute Indexed, Y	<b>LDX addr, Y</b>	BE	x	x	x	3	4 <sup>1,3</sup>
DP Indexed, Y	<b>LDX dp, Y</b>	B6	x	x	x	2	4 <sup>1,2</sup>

\* Add 1 byte if x = 0 (16-bit index registers)

1 Add 1 cycle if x = 0 (16-bit index registers)

2 Add 1 cycle if low byte of Direct Page register is other than zero (DL< >0)

3 Add 1 cycle if adding index crosses a page boundary

**Load Index Register Y from Memory**

**LDY**

Load index register **Y** with the data located at the effective address specified by the operand.

**8-bit index registers (all processors):** Data is eight-bit.

**16-bit index registers (65802/65816 only, x = 0):** Data is sixteen-bit: the low-order eight bits are located at the effective address; the high-order eight bits are located at the effective address plus one.

**Flags Affected:**

**n - - - - z -**

n Set if most significant bit of loaded value is set; else cleared.

z Set if value loaded is zero; else cleared.

**Codes:**

Addressing Mode	Syntax	Opcode (hex)	Available on:			# of Bytes	# of Cycles
			6502	65C02	65802/816		
Immediate	<b>LDY</b> # <i>const</i>	A0	x	x	x	2*	2 <sup>1</sup>
Absolute	<b>LDY</b> <i>addr</i>	AC	x	x	x	3	4 <sup>1</sup>
Direct Page (also DP)	<b>LDY</b> <i>dp</i>	A4	x	x	x	2	3 <sup>1,2</sup>
Absolute Indexed, X	<b>LDY</b> <i>addr</i> , <i>X</i>	BC	x	x	x	3	4 <sup>1,3</sup>
DP Indexed, X	<b>LDY</b> <i>dp</i> , <i>X</i>	B4	x	x	x	2	4 <sup>1,2</sup>

\* Add 1 byte if x = 0 (16-bit index registers)

1 Add 1 cycle if x = 0 (16-bit index registers)

2 Add 1 cycle if low byte of Direct Page register is other than zero (DL< >0)

3 Add 1 cycle if adding index crosses a page boundary

**Logical Shift Memory or Accumulator Right**

**LSR**

Logical shift the contents of the location specified by the operand right one bit. That is, bit zero takes on the value originally found in bit one, bit one takes the value originally found in bit two, and so on; the leftmost bit (bit 7 if the **m** memory select flag is one when the instruction is executed or bit 15 if it is zero) is cleared; the rightmost bit, bit zero, is transferred to the carry flag. This is the arithmetic equivalent of unsigned division by two.

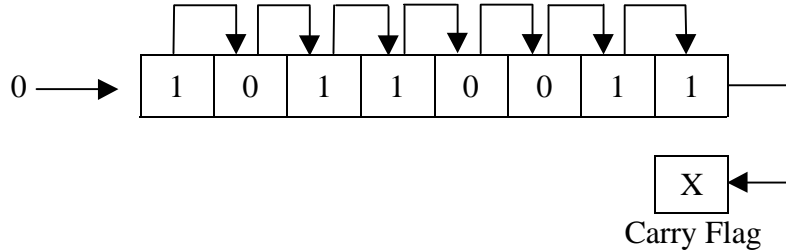

Figure 18-6 LSR

**8-bit accumulator/memory (all processors):** Data shifted is eight-bit.

**16-bit accumulator/memory (65802/65816 only, m = 0):** Data shifted is sixteen-bit: if in memory, the low-order eight bits are located at the effective address; the high-order eight bits are located at the effective address plus one.

**Flags Affected:** n - - - - z c

**n Cleared.**

**z Set if result is zero; else cleared.**

**c Low bit becomes carry: set if low bit was set; cleared if low bit was zero.**

**Codes:**

Addressing Mode	Syntax	Opcode (hex)	Available on:			# of Bytes	# of Cycles
			650 2	65C0 2	65802/8 16		
Accumulator	<b>LSR</b> A	4A	x	x	x	1	2
Absolute	<b>LSR</b> addr	4E	x	x	x	3	6 <sup>1</sup>
Direct Page (also DP)	<b>LSR</b> dp	46	x	x	x	2	5 <sup>1,2</sup>
Absolute Indexed, X	<b>LSR</b> addr, X	5E	x	x	x	3	7 <sup>1,3</sup>
DP Indexed, X	<b>LSR</b> dp, X	56	x	x	x	2	6 <sup>1,2</sup>

1 Add 2 cycles if m = 0 (16-bit memory/accumulator)

2 Add 1 cycle if low byte of Direct Page register is other than zero (DL<>0)

3 Subtract 1 cycle if 65C02 and no page boundary crossed

**Block Move Next**

**MVN**

Moves (copies) a block of memory to a new location. The source, destination and length operands of this instruction are taken from the **X**, **Y**, and **C** (double accumulator) registers; these should be loaded with the correct values before executing the **MVN** instruction.

The source address for **MVN**, taken from the **X** register, should be the starting address (lowest in memory) of the block to be moved. The destination address, in the **Y** register, should be the new starting address for the moved block. The length, loaded into the double accumulator (the value in **C** is always used, regardless of the setting of the **m** flag) should be the length of the block to be moved *minus one*; if **C** contains \$0005, six bytes will be moved. The two operand bytes of the **MVN** instruction specify the *banks* holding the two blocks of memory: the first operand byte (of object code) specifies the destination bank; the second operand byte specifies the source bank.

The execution sequence is: the first byte is moved from the address in **X** to the address in **Y**; then **X** and **Y** are incremented, **C** is decremented, and the *next* byte is moved; this process continues until the number of bytes specified by the value in **C plus one** is moved. In other words, until the value in **C** is \$FFFF.

If the source and destination blocks do not overlap, then the source block remains intact after it has been copied to the destination.

If the source and destination blocks do overlap, then **MVN** should be used only if the destination is *lower* than the source to avoid overwriting source bytes before they've been copied to the destination. If the destination is higher, then the **MVP** instruction should be used instead.

When execution is complete, the value in **C** is \$FFFF, registers **X** and **Y** each point one byte past the end of the blocks to which they were pointing, and the data bank register holds the **destination** bank value (the first operand byte).

**Assembler syntax** for the block move instruction calls for the operand field to be coded as two addresses, source first, then destination – the move intuitive ordering, but the opposite of the actual operand order in the object code. The assembler strips the bank bytes from the addresses (ignoring the rest) and reverses them to object code order. If a block move instruction is interrupted, it may be resumed automatically via execution of an **RTI** if all of the registers are restored or intact. The value pushed onto the stack when a block move is interrupted is the address of the block move instruction. The current byte-move is completed before the interrupt is serviced.

If the index registers are in eight-bit mode ( $x = 1$ ), or the processor is in 6502 emulation mode ( $e = 1$ ), then the blocks being specified must necessarily be in page zero since the high bytes of the index registers will contain zeroes.

**Flags Affected:**        - - - - -

**Codes:**

Addressing Mode	Syntax	Opcode	Available on:		# of	# of	
		(hex)	6502	65C02	65802/816	Bytes	Cycles
Block Move	<b>MVN</b> <i>srcbk,destbk</i>	54			x	3	*

\* 7 cycles per byte moved

**Block Move Previous**

**MVP**

Moves (copies) a block of memory to a new location. The source, destination and length operands of this instruction are taken from the **X**, **Y**, and **C** (double accumulator) registers; these should be loaded with the correct values before executing the **MVP** instruction.

The source address for **MVP**, taken from the **X** register, should be the ending address (highest in memory) of the block to be moved. The destination address, in the **Y** register, should be the new ending address for the moved block. The length, loaded into the double accumulator (the value in **C** is always used, regardless of the setting of the **m** flag) should be the length of the block to be moved *minus one*; if **C** contains \$0005, six bytes will be moved. The two operand bytes of the **MVP** instruction specify the *banks* holding the two blocks of memory: the first operand byte (of object code) specifies the destination bank; the second operand byte specifies the source bank.

The execution sequence is: the first byte is moved from the address in **X** to the address in **Y**; then **X** and **Y** are decremented, **C** is decremented, and the *previous* byte is moved; this process continues until the number of bytes specified by the value in **C plus one** is moved. In other words, until the value in **C** is \$FFFF.

If the source and destination blocks do not overlap, then the source block remains intact after it has been copied to the destination.

If the index registers are in eight-bit mode ( $x = 1$ ), or the processor is in 6502 emulation mode ( $e = 1$ ), then the blocks If the source and destination blocks do overlap, then **MVP** should be used only if the destination is *higher* than the source to avoid overwriting source bytes before they've been copied to the destination. If the destination is lower, then the **MVN** instruction should be used instead.

When execution is complete, the value in **C** is \$FFFF, registers **X** and **Y** each point one byte past the beginning of the blocks to which they were pointing, and the data bank register holds the **destination** bank value (the first operand byte).

**Assembler syntax** for the block move instruction calls for the operand field to be coded as two addresses, source first, then destination – the more intuitive ordering, but the opposite of the actual operand order in the object code. The assembler strips the bank bytes from the addresses (ignoring the rest) and reverses them to object code order. If a block move instruction is interrupted, it may be resumed automatically via execution of an **RTI** if all of the registers are restored or intact. The value pushed onto the stack when a block move is interrupted is the address of the block move instruction. The current byte-move is completed before the interrupt is serviced. being specified must necessarily be in page zero since the high bytes of the index registers will contain zeroes.

**Flags Affected:**     - - - - -

**Codes:**

Addressing Mode	Syntax	Opcode	Available on:			# of	# of
		(hex)	6502	65C02	65802/816	Bytes	Cycles
Block Move	<b>MVP</b> <i>srcbk, destbk</i>	44			x	3	*

\* 7 cycles per byte moved



**No Operation**

**NOP**

Executing a **NOP** takes no action; it has no effect on any 65x registers or memory, except the program counter, which is incremented once to point to the next instruction.

Its primary uses are during debugging, where it is used to “patch out” unwanted code, or as a placeholder, included in the assembler source, where you anticipate you may have to “patch in” instructions, and want to leave a “hole” for the patch.

**NOP** may also be used to expand timing loops – each **NOP** instruction takes two cycles to execute, so adding one or more may help fine tune a timing loop.

**Flags Affected:**     - - - - -

**Codes:**

<i>Addressing Mode</i>	<i>Syntax</i>	<i>Opcode</i>	<i>Available on:</i>			<i># of</i>	<i># of</i>
		<i>(hex)</i>	<i>6502</i>	<i>65C02</i>	<i>65802/816</i>	<i>Bytes</i>	<i>Cycles</i>
Implied	<b>NOP</b>	EA	x	x	x	1	2

## OR Accumulator with Memory

**ORA**

Bitwise logical OR the data located at the effective address specified by the operand with the contents of the accumulator. Each bit in the accumulator is ORed with the corresponding bit in memory. The result is stored into the same accumulator bit.

The truth table for the logical OR operation is:

		<i>Second Operand</i>	
		0	1
<i>First Operand</i>	0	0	1
	1	1	1

Figure 18-7 Logical OR Truth Table

A 1 or logical true results if either of the two operands of the OR operation is true.

**8-bit accumulator (all processors):** Data ORed from memory is eight-bit.

**16-bit accumulator (65802/65816 only, m=0):** Data ORed from memory is sixteen-bit: the low-order eight bits are located at the effective address; the high-order eight bits are located at the effective address plus one.

**Flags Affected:**      **n - - - - z -**

**n Set if most significant bit of result is set; else cleared.**

**z Set if result is zero; else cleared.**

## The Western Design Center

### Codes:

Addressing Mode <sup>++</sup>	Syntax	Opcode (hex)	Available on:			# of Bytes	# of Cycles
			6502	65C02	65802/816		
Immediate	<b>ORA</b> # <i>const</i>	09	x	x	x	2*	2 <sup>1</sup>
Absolute	<b>ORA</b> <i>addr</i>	0D	x	x	x	3	4 <sup>1</sup>
Absolute Long	<b>ORA</b> <i>long</i>	0F			x	4	5 <sup>1</sup>
Direct Page (also DP)	<b>ORA</b> <i>dp</i>	05	x	x	x	2	3 <sup>1,2</sup>
DP Indirect	<b>ORA</b> ( <i>dp</i> )	12		x	x	2	5 <sup>1,2</sup>
DP Indirect Long	<b>ORA</b> [ <i>dp</i> ]	07			x	2	6 <sup>1,2</sup>
Absolute Indexed, X	<b>ORA</b> <i>addr</i> , <i>X</i>	1D	x	x	x	3	4 <sup>1,3</sup>
Absolute Long Indexed, X	<b>ORA</b> <i>long</i> , <i>X</i>	1F			x	4	5 <sup>1</sup>
Absolute Indexed, Y	<b>ORA</b> , <i>addr</i> , <i>Y</i>	19	x	x	x	3	4 <sup>1,3</sup>
DP Indexed, X	<b>ORA</b> , <i>dp</i> , <i>X</i>	15	x	x	x	2	4 <sup>1,2</sup>
DP Indexed Indirect, X	<b>ORA</b> ( <i>dp</i> , <i>X</i> )	01	x	x	x	2	6 <sup>1,2</sup>
DP Indirect Indexed, Y	<b>ORA</b> , ( <i>dp</i> ), <i>Y</i>	11	x	x	x	2	5 <sup>1,2,3</sup>
DP Indirect Long Indexed, Y	<b>ORA</b> [ <i>dp</i> ], <i>Y</i>	17			x	2	6 <sup>1,2</sup>
Stack Relative (also SR)	<b>ORA</b> <i>sr</i> , <i>S</i>	03			x	2	4 <sup>1</sup>
SR Indirect Indexed, Y	<b>ORA</b> ( <i>sr</i> , <i>S</i> ), <i>Y</i>	13			x	2	7 <sup>1</sup>

<sup>++</sup> ORA, a Primary Group Instruction, has available all of the Primary Group addressing modes and bit patterns

\* Add 1 byte if m = 0 (16-bit memory/accumulator)

1 Add 1 cycle if m = 0 (16-bit memory/accumulator)

2 Add 1 cycle if low byte of Direct Page register is other than zero (DL<>0)

3 Add 1 cycle if adding index crosses a page boundary

**Push Effective Absolute Address**

**PEA**

Push the sixteen-bit operand (typically an absolute address) onto the stack. The stack pointer is decremented twice. This operation always pushes sixteen bits of data, irrespective of the settings of the **m** and **x** mode select flags.

Although the mnemonic suggests that the sixteen-bit value pushed on the stack be considered an address, the instruction may also be considered a “push sixteen-bit immediate data” instruction, although the syntax of immediate addressing is not used. The assembler syntax is that of the absolute addressing mode, that is, a label or sixteen-bit value in the operand field. Unlike all other instructions that use this assembler syntax, the **effective address** itself, rather than the data stored at the effective address, is what is accessed (and in this case, pushed onto the stack).

**Flags Affected:**     - - - - -

**Codes:**

<i>Addressing Mode</i>	<i>Syntax</i>	<i>Opcode (hex)</i>	<i>Available on:</i>			<i># of Bytes</i>	<i># of Cycles</i>
Stack (Absolute)	<b>PEA</b> <i>addr</i>	F4	6502	65C02	65802/816	x 3	5

**Push Effective Indirect Address**

**PEI**

Push the sixteen-bit value located at the address formed by adding the direct page offset specified by the operand to the data page register. The mnemonic implies that the sixteen-bit data pushed is considered an address, although it can be any sixteen-bit data. This operation always pushes sixteen bits of data, irrespective of the settings of the **m** and **x** mode select flags.

The first byte pushed is the byte at the direct page offset plus one (the high byte of the double byte stored at the direct page offset). The byte at the direct page offset itself (the low byte) is pushed next. The stack pointer now points to the next available stack location, directly below the last byte pushed.

The assembler syntax is that of direct page indirect; however, unlike other instructions which use this assembler syntax, the *effective indirect address*, rather than the data stored at that address, is what is accessed and pushed onto the stack.

**Flags Affected:**     - - - - -

**Codes:**

<i>Addressing Mode</i>	<i>Syntax</i>	<i>Opcode (hex)</i>	<i>Available on:</i>			<i># of Bytes</i>	<i># of Cycles</i>
			<i>6502</i>	<i>65C02</i>	<i>65802/81 6</i>		
Stack (Direct Page Indirect)	PEI ( <i>dp</i> )	D4			x	2	6 <sup>1</sup>

1 Add 1 cycle if low byte of Direct Page register is other than zero (DL<>0)

**Push Effective PC Relative Indirect Address**

**PER**

Add the current value of the program counter to the sixteen-bit signed displacement in the operand, and push the result on the stack. This operation always pushes sixteen bits of data, irrespective of the settings of the **m** and **x** mode select flags.

The high byte of the sum is pushed first, then the low byte is pushed. After the instruction is completed, the stack pointer points to the next available stack location, immediately below the last by pushed.

Because **PER**'s operand is a displacement relative to the current value of the program counter (as with the branch instructions), this instruction is helpful in writing self-relocatable code in which an address within the program (typically of a data area) must be accessed. The address pushed onto the stack will be the *run-time* address of the data area, regardless of where the program was loaded in memory; it may be pulled into a register, stored in an indirect pointer, or used on the stack with the stack relative indirect indexed addressing mode to access the data at that location.

As is the case with the branch instructions, the syntax used is to specify as the operand the label of the data area you want to reference. This location must be in the **program bank**, since the displacement is relative to the program counter. The assembler converts the assembly-time label into a displacement from the assembly-time address of the next instruction.

The value of the program counter used in the addition is the address of the *next* instruction, that is, the instruction *following* the **PER** instruction.

**PER** may also be used to push return addresses on the stack, either as part of a simulated branch-to-subroutine or to place the return address beneath the stacked parameters to a subroutine call; always remember that a pushed return address should be the desired return address *minus one*.

**Flags Affected:**     - - - - -

**Codes:**

<i>Addressing Mode</i>	<i>Syntax</i>	<i>Opcode (hex)</i>	<i>Available on:</i>			<i># of Bytes</i>	<i># of Cycle</i>
			6502	65C02	65802/816		
Stack (Program Counter Relative Long)	<b>PER</b> <i>label</i>	62			x	3	6

**Push Accumulator**

**PHA**

Push the accumulator onto the stack. The accumulator itself is uncharged.

**8-bit accumulator (all processors):** The single byte contents of the accumulator are pushed – they are stored to the location pointed to by the stack pointer and the stack pointer is decremented.

**16-bit accumulator (65802/65816 only, m = 0):** Both accumulator bytes are pushed. The high byte is pushed first, then the low byte. The stack point now points to the next available stack location, directly below the last byte pushed.

**Flags Affected:** - - - - -

**Codes:**

<i>Addressing Mode</i>	<i>Syntax</i>	<i>Opcode</i>		<i>Available on:</i>			<i># of Bytes</i>	<i># of Cycles</i>
		<i>(hex)</i>	<i>6502</i>	<i>65C02</i>	<i>65802/816</i>			
Stack (Push)	<b>PHA</b>	48	x	x	x	1	3 <sup>1</sup>	

1 Add 1 cycle if m=0 (16-bit memory/accumulator)

**Push Data Bank Register**

**PHB**

Push the contents of the data bank register onto the stack.

The single-byte contents of the data bank registers are pushed onto the stack; the stack pointer now points to the next available stack location, directly below the byte pushed. The data bank register itself is unchanged. Since the data bank register is an eight-bit register, only one byte is pushed onto the stack, regardless of the settings of the **m** and **x** mode select flags.

While the 65816 always generates 24-bit addresses, most memory references are specified by a sixteen-bit address. These addresses are concatenated with the contents of the data bank register to form a full 24-bit address. This instruction lets the current value of the data bank register be saved prior to loading a new value.

**Flags Affected:**     - - - - -

**Codes:**

<i>Address Mode</i>	<i>Syntax</i>	<i>Opcode</i>	<i>Available on:</i>			<i># of</i>	<i># of</i>
		<i>(hex)</i>	<i>6502</i>	<i>65C02</i>	<i>65802/816</i>	<i>Bytes</i>	<i>Cycles</i>
Stack (Push)	<b>PHB</b>	8B			x	1	3



**Push Direct Page Register**

**PHD**

Push the contents of the direct page register **D** onto the stack.

Since the direct page register is always a sixteen-bit register, this is always a sixteen-bit operation, regardless of the settings of the **m** and **x** mode select flags. The high byte of the direct page register is pushed first, then the low byte. The direct page register itself is unchanged. The stack pointer now points to the next available stack location, directly below the last byte pushed.

By pushing the **D** register onto the stack, the local environment of a calling subroutine may easily be saved a called subroutine before modifying the **D** register to provide itself with its own direct page memory.

**Flags Affected:**     - - - - -

**Codes:**

<i>Address Mode</i>	<i>Syntax</i>	<i>Opcode (hex)</i>	<i>Available on:</i>			<i># of Bytes</i>	<i># of Cycles</i>	
Stack (Push)	<b>PHD</b>	0B	6502	65C02	65802/816	x	1	4

**Push Program Bank Register**

**PHK**

Push the program bank register onto the stack.

The single-byte contents of the program bank register are pushed. The program bank register itself is unchanged. The stack pointer now points to the next available stack location, directly below the byte pushed. Since the program bank register is an eight-bit register, only one byte is pushed onto the stack, regardless of the settings of the **m** and **x** mode select flags.

While the 65816 always generates 24-bit addresses, most jumps and branches specify only a sixteen-bit address. These addresses are concatenated with the contents of the program bank register to form a full 24-bit address. This instruction lets you determine the current value of the program bank register – for example, if you want the data bank to be set to the same value as the program bank.

**Flags Affected:**     - - - - -

**Codes:**

<i>Address Mode</i>	<i>Syntax</i>	<i>Opcode (hex)</i>	<i>Available on:</i>			<i># of Bytes</i>	<i># of Cycles</i>
			<i>6502</i>	<i>65C02</i>	<i>65802/816</i>		
Stack (Push)	<b>PHK</b>	4B			x	1	3

**Push Processor Status Register**

**PHP**

Push the contents of the processor status register **P** onto the stack.

Since the status register is always an eight-bit register, this is always an eight-bit operation, regardless of the settings of the **m** and **x** mode select flags on the 65802/65816. The status register contents are not changed by the operation. The stack pointer now points to the next available stack location, directly below the byte pushed.

This provides the means for saving either the current mode settings or a particular set of status flags so they may be restored or in some other way used later.

Note, however, that the **e** bit (the 6502 emulation mode flag on the 65802/65816) is **not** pushed onto the stack or otherwise accessed or saved. The only access to the **e** flag is via the **XCE** instruction.

**Flags Affected:**     - - - - -

**Codes:**

<i>Address Mode</i>	<i>Syntax</i>	<i>Opcode (hex)</i>	<i>Available on:</i>			<i># of Bytes</i>	<i># of Cycles</i>
			<i>6502</i>	<i>65C02</i>	<i>65802/816</i>		
Stack (Push)	<b>PHP</b>	08	x	x	x	1	3

**Push Index Register**

**PHX**

Push the contents of the **X** index register onto the stack. The register itself is unchanged.

**8-bit index registers (all processors):** The eight-bit contents of the index register are pushed onto the stack. The stack pointer now points to the next available stack location, directly below the byte pushed.

**16-bit index registers (65802/65816 only, x=0):** The sixteen-bit contents of the index register are pushed. The high byte is pushed first, then the low byte. The stack pointer now points to the next available stack location, directly below the last byte pushed.

**Flags Affected:**     - - - - -

**Codes:**

<i>Address Mode</i>	<i>Syntax</i>	<i>Opcode (hex)</i>	<i>Available on:</i>			<i># of Bytes</i>	<i># of Cycles</i>
			<i>6502</i>	<i>65C02</i>	<i>65802/816</i>		
Stack (Push)	PHX	DA		x	x	1	3 <sup>1</sup>

1 Add 1 cycle if x=0 (16-bit index registers)

**Push Index Register**

**PHY**

Push the contents of the **Y** index register onto the stack. The register itself is unchanged.

**8-bit index registers (all processors):** The eight-bit contents of the index register are pushed onto the stack. The stack pointer now points to the next available stack location, directly below the byte pushed.

**16-bit index registers (65802/65816 only, x = 0):** The sixteen-bit contents of the index register are pushed. The high byte is pushed first, then the low byte. The stack pointer now points to the next available stack location, directly below the last byte pushed.

**Flags Affected:**     - - - - -

**Codes:**

<i>Address Mode</i>	<i>Syntax</i>	<i>Opcode (hex)</i>	<i>Available on:</i>		<i># of Bytes</i>	<i># of Cycles</i>	
			<i>6502</i>	<i>65C02</i>			<i>65802/816</i>
Stack (Push)	PHY	5A		x	x	1	3 <sup>1</sup>

1 Add 1 cycle if x=0 (16-bit index registers)

**Pull Accumulator**

**PLA**

Pull the value on the top of the stack into the accumulator. The previous contents of the accumulator are destroyed.

**8-bit accumulator (all processors):** The stack pointer is first incremented. Then the byte pointed to by the stack pointer is loaded into the accumulator.

**16-bit accumulator (65802/65816 only, m = 0):** Both accumulator bytes are pulled. The accumulator's low byte is pulled first, then the high byte is pulled.

Note that unlike some other microprocessors, the 65x pull instructions set the negative and zero flags.

**Flags Affected:**      **n - - - - z -**

**n** Set if most significant bit of pulled value is set; else cleared.

**z** Set if value pulled is zero; else cleared.

**Codes:**

<i>Address Mode</i>	<i>Syntax</i>	<i>Opcode (hex)</i>	<i>Available on:</i>			<i># of Bytes</i>	<i># of Cycles</i>
			<i>6502</i>	<i>65C02</i>	<i>65802/816</i>		
Stack (Pull)	PLA	68	x	x	x	1	4 <sup>1</sup>

a) Add 1 cycle if m=0 (16-bit memory/accumulator)

**Pull Data Bank Register**

**PLB**

Pull the eight-bit value on top of the stack into the data bank register **B**, switching the data bank to that value. All instructions which reference data that specify only sixteen-bit addresses will get their bank address from the value pulled into the data bank register. This is the only instruction that can modify the data bank register.

Since the bank register is an eight-bit register, only one byte is pulled from the stack, regardless of the settings of the **m** and **x** mode select flags. The stack pointer is first incremented. Then the byte pointed to by the stack pointer is loaded into the register.

**Flags Affected:**

**n - - - - z -**

n Set if most significant bit of pulled value is set; else cleared.

z Set if value pulled is zero; else cleared.

**Codes:**

<i>Address Mode</i>	<i>Syntax</i>	<i>Opcode (hex)</i>	<i>Available on:</i>			<i># of Bytes</i>	<i># of Cycles</i>
			<i>6502</i>	<i>65C02</i>	<i>65802/816</i>		
Stack (Pull)	PLB	AB			x	1	4

**Pull Direct Page Register**

**PLD**

Pull the sixteen-bit value on top of the stack into the direct page register **D**, switching the direct page to that value.

**PLD** is typically used to restore the direct page register to a previous value.

Since the direct page register is a sixteen-bit register, two byte are pulled from the stack, regardless of the settings of the **m** and **x** mode select flags. The low byte of the direct page register is pulled first, then the high byte. The stack pointer now points to where the high byte just pulled was stored; this is now the next available stack location.

**Flags Affected:**      **n - - - - z -**

**n** Set if most significant bit of pulled value is set; else cleared.

**z** Set if value pulled is zero; else cleared.

**Codes:**

<i>Addressing Mode</i>	<i>Syntax</i>	<i>Opcode (hex)</i>	<i>Available on:</i>			<i># of Byte</i>	<i># of Cycle s</i>
			<i>6502</i>	<i>65C02</i>	<i>65802/816</i>		
Stack (Pull)	<b>PLD</b>	2B			x	1	5





**Pull Index Register X from Stack**

**PLX**

Pull the value on the top of the stack into the **X** index register. The previous contents of the register are destroyed.

**8-bit index registers (all processors):** The stack pointer is first incremented. Then the byte pointed to by the stack pointer is loaded into the register.

**16-bit index registers (65802/65816 only, x = 0):** Both bytes of the index register are pulled. First the low-order byte of the index register is pulled, then the high-order byte of the index register is pulled.

Unlike some other microprocessors, the 65x instructions to pull an index register affect the negative and zero flags.

**Flags Affected:**      **n - - - - z -**

**n** Set if most significant bit of pulled value is set; else cleared.

**z** Set if value pulled is zero; else cleared.

**Codes:**

<i>Address Mode</i>	<i>Syntax</i>	<i>Opcode (hex)</i>	<i>Available on:</i>			<i># of Bytes</i>	<i># of Cycles</i>
			<i>6502</i>	<i>65C02</i>	<i>65802/816</i>		
Stack (Pull)	PLX	FA		x	x	1	4 <sup>1</sup>

1. Add 1 cycle if x = 0 (16-bit index registers)

**Pull Index Register Y from Stack**

**PLY**

Pull the value on the top of the stack into the **Y** index register. The previous contents of the register are destroyed.

**8-bit index registers (all processors):** The stack pointer is first incremented. Then the byte pointed to by the stack pointer is loaded into the register.

**16-bit index registers (65802/65816 only, x = 0):** Both bytes of the index register are pulled. First the low-order byte of the index register is pulled, then the high-order byte of the index register is pulled.

Unlike some other microprocessors, the 65x instructions to pull an index register affect the negative and zero flags.

**Flags Affected:**

**n - - - - z -**

n Set if most significant bit of pulled value is set; else cleared.

z Set if value pulled is zero; else cleared.

**Codes:**

<i>Addressing Mode</i>	<i>Syntax</i>	<i>Opcode (hex)</i>	<i>Available to:</i>			<i># of Bytes</i>	<i># of Cycles</i>
			<i>6502</i>	<i>65C02</i>	<i>65802/816</i>		
Stack (Pull)	PLY	7A		x	x	1	4 <sup>1</sup>

1. <sub>1</sub> Add 1 cycle if x = 0 (16-bit index registers)

**Reset Status Bits**

**REP**

For each bit set to one in the operand byte, reset the corresponding bit in the status register to zero. For example, if bit three is set in the operand byte, bit three in the status register (the decimal flag) is reset to zero by this instruction. Zeroes in the operand byte cause no change to their corresponding status register bits.

This instruction lets you reset *any* flag or flags in the status register with a single two-byte instruction. Further, it is the only direct means of resetting several of the flags, including the **m** and **x** mode select flags (although instructions that pull the **P** status register affect the **m** and **x** mode select flags).

**6502 emulation mode (65802/65816, e=1):** Neither the break flag nor bit five (the 6502's undefined flag bit) are affected by **REP**.

**Flags Affected:**      **n v - - d i z c**      (65802/65816 emulation mode e=1)

**n v m x d i z c**      (65802/65816 native mode e=0)

All flags for which an operand bit is set are reset to zero.

All other flags are unaffected by the instruction.

**Codes:**

<i>Addressing Mode</i>	<i>Syntax</i>	<i>Opcode (hex)</i>	<i>Available to:</i>			<i># of Bytes</i>	<i># of Cycles</i>
			<i>6502</i>	<i>65C02</i>	<i>65802/816</i>		
Immediate	REP # <i>const</i>	C2			x	2	3

**Rotate Memory or Accumulator Left**

**ROL**

Rotate the contents of the location specified by the operand left one bit. Bit one takes on the value originally found in bit zero, bit two takes the value originally in bit one, and so on; the rightmost bit, bit zero, takes the value in the carry flag; the leftmost bit (bit 7 on the 6502 and 65C02 or if m = 1 on the 65802/65816, or bit 15 if m = 0) is transferred into the carry flag.

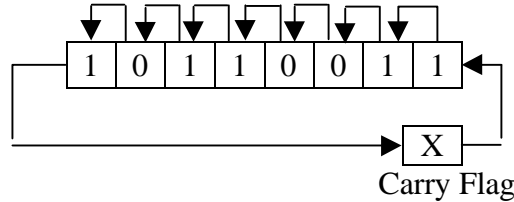

**Figure 18-8 ROL**

**8-bit accumulator/memory (all processors):** Data rotated is eight bits, plus carry.

**16-bit accumulator/memory (65802/65816 only, m=0):** Data rotated is sixteen bits, plus carry: if in memory, the low-order eight bits are located at the effective address; the high eight bits are located at the effective address plus one.

**Flags Affected:**

**n - - - - z c**

n Set if most significant bit of result is set; else cleared.

z Set if result is zero; else cleared.

c High bit becomes carry: set if high bit was set; cleared if high bit was clear.

**Codes:**

Address Mode	Syntax	Opcode (hex)	Available to:			# of Bytes	# of Cycles
			6502	65C02	65802/816		
Accumulator	<b>ROL</b> A	2A	x	x	x	1	2
Absolute	<b>ROL</b> addr	2E	x	x	x	3	6 <sup>1</sup>
Direct Page (also DP)	<b>ROL</b> dp	26	x	x	x	2	5 <sup>1,2</sup>
Absolute Indexed, X	<b>ROL</b> addr, X	3E	x	x	x	3	7 <sup>1,3</sup>
DP Indexed, X	<b>ROL</b> dp, X	36	x	x	x	2	6 <sup>1,2</sup>

1 Add 2 cycles if m=0 (16-bit memory/accumulator)

2 Add 1 cycle if low byte of Direct Page register is other than zero (DL<>0)

3 Subtract 1 cycle if 65C02 and no page boundary crossed

**Rotate Memory or Accumulator Right**

**ROR**

Rotate the contents of the location specified by the operand right one bit. Bit zero takes on the value originally found in bit one, bit one takes the value originally in bit two, and so on; the leftmost bit (bit 7 on the 6502 and 65C02 or if **m = 1** on the 65802/65816, or bit 15 if **m = 0**) takes the value in the carry flag; the rightmost bit, bit zero, is transferred into the carry flag.

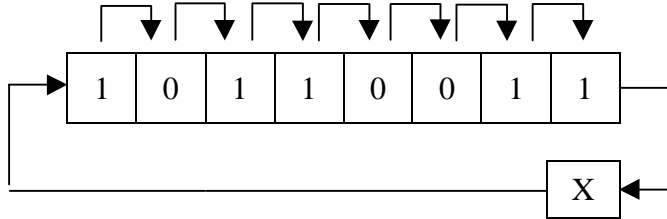

Figure 18-9 ROR

**8-bit accumulator/memory (all processors):** Data rotated is eight bits, plus carry.

**16-bit accumulator/memory (65802/65816 only, m=0):** Data rotated is sixteen bits, plus carry: if in memory, the low-order eight bits are located at the effective address; the high-order eight bits are located at the effective address plus one.

**Flags Affected:**     **n - - - - z c**  
**n** Set if most significant bit of result is set; else cleared.  
**z** Set if result is zero; else cleared.  
**c** Low bit becomes carry: set if low bit was set; cleared if low bit was clear.

**Codes:**

Address Mode	Syntax	Opcode (hex)	Available to:			# of Bytes	# of Cycles
			6502	65C02	65802/816		
Accumulator	<b>ROR</b> A	6A	x	x	x	1	2
Absolute	<b>ROR</b> addr	6E	x	x	x	3	6 <sup>1</sup>
Direct Page (also DP)	<b>ROR</b> dp	66	x	x	x	2	5 <sup>1,2</sup>
Absolute Indexed, X	<b>ROR</b> addr, X	7E	x	x	x	3	7 <sup>1,3</sup>
DP Indexed, X	<b>ROR</b> dp, X	76	x	x	x	2	6 <sup>1,2</sup>

- 1 Add 2 cycles if m = 0 (16-bit memory/accumulator)
- 2 Add 1 cycle if low byte of Direct Page register is other than zero (DL < > 0)
- 3 Subtract 1 cycle if 65C02 and no page boundary crossed

**Return from Interrupt**

**RTI**

Pull the status register and the program counter from the stack. If the 65802/65816 is set to native mode (e = 0), also pull the program bank register from the stack.

**RTI** pulls values off the stack in the reverse order they were pushed onto it by hardware or software interrupts. The **RTI** instruction, however, has no way of knowing whether the values pulled off the stack into the status register and the program counter are valid – or even, for that matter, that an interrupt has ever occurred. It blindly pulls the first three (or four) bytes off the top of the stack and stores them into the various registers.

Unlike the **RTS** instruction, the program counter address pulled off the stack is the exact address to return to; the value on the stack is the value loaded into the program counter. It does not need to be incremented as a subroutine’s return address does.

Pulling the status register gives the status flags the values they had immediately prior to the start of interrupt-processing.

One extra byte is pulled in the 65802/65816 native mode than in emulation mode, the same extra byte that is pushed by interrupts in native mode, the program bank register. It is therefore essential that the return from interrupt be executed in the same mode (emulation or native) as the original interrupt.

**6502, 65C02, and Emulation Mode (e = 1):** The status register is pulled from the stack, then the program counter is pulled from the stack (three bytes are pulled).

**65802/65816 Native Mode (e = 0):** The status register is pulled from the stack, then the program counter is pulled from the stack, then the program bank register is pulled from the stack (four bytes are pulled).

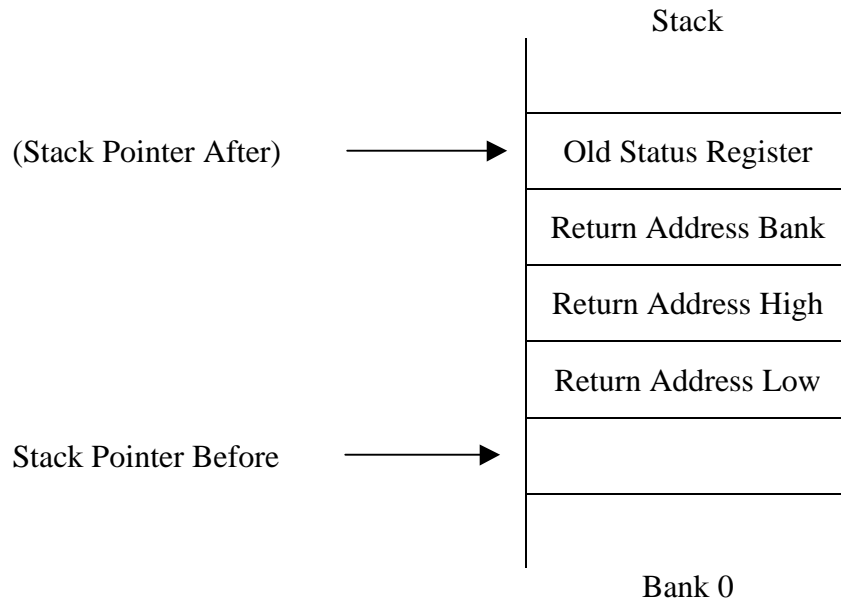

Figure 18-10 Native Mode Stack before RTI.

**Flags Affected:**

**n v - - d i z c** (6502, 65C02,  
65802/65816 emulation mode e = 1)  
**n v m x d i z c** (65802/65816 native mode e = 0)

All flags are restored to their values prior to interrupt (each flag takes the value of its corresponding bit in the stacked status byte, except that the Break flag is ignored).

**The Western Design Center**

**Codes:**

<i>Addressing Mode</i>	<i>Syntax</i>	<i>Opcode (hex)</i>	<i>Available to:</i>			<i># of Bytes</i>	<i># of Cycles</i>
			<i>6502</i>	<i>65C02</i>	<i>65802/816</i>		
Stack (RTI)	RTI	40	x	x	x	1	6 <sup>1</sup>

1 Add 1 cycle for 65802/65816 native mode (e=0)



**Return from Subroutine Long**

**RTL**

Pull the program counter (incrementing the stacked, sixteen-bit value by one before loading the program counter with it), then the program bank register from the stack.

When a subroutine in another bank is called (via a jump to subroutine long instruction), the current bank address is pushed onto the stack along with the return address. To return to the calling bank, a long return instruction must be executed, which first pulls the return address from the stack, increments it, and loads the program counter with it, then pulls the calling bank from the stack and loads the program bank register. This transfers control to the instruction immediately following the original jump to subroutine long.

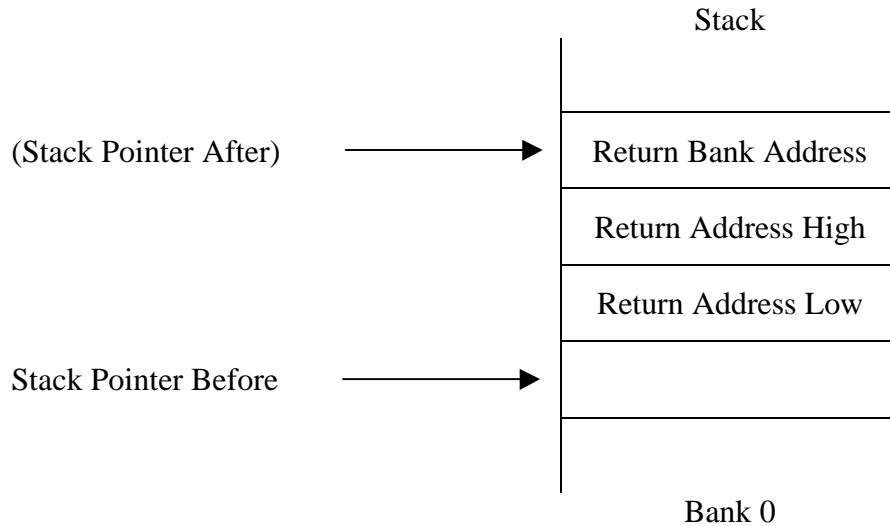

**Figure 18-11 Stack before RTL**

**Flags Affected:** - - - - -

**Codes:**

<i>Address Mode</i>	<i>Syntax</i>	<i>Opcode (hex)</i>	<i>Available to:</i>			<i># of Bytes</i>	<i># of Cycles</i>
			<i>6502</i>	<i>65C02</i>	<i>65802/8 16</i>		
Stack (RTL)	RTL	6B			x	1	6

**Return from Subroutine**

**RTS**

Pull the program counter, incrementing the stacked, sixteen-bit value by one before loading the program counter with it.

When a subroutine is called (via a jump to subroutine instruction), the current return address is pushed onto the stack. To return to the code following the subroutine call, a return instruction must be executed, which pulls the return address from the stack, increments it, and loads the program counter with it, transferring control to the instruction immediately following the jump to subroutine.

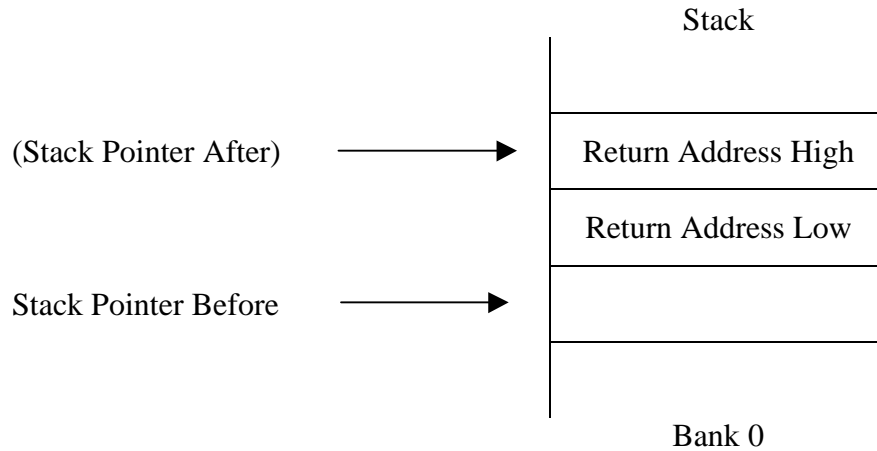

**Figure 18-12 Stack before RTS**

**Flags Affected:** - - - - -

**Codes:**

<i>Addressing Mode</i>	<i>Syntax</i>	<i>Opcode (hex)</i>	<i>Available to:</i>			<i># of Bytes</i>	<i># of Cycles</i>
			<i>6502</i>	<i>65C02</i>	<i>65802/816</i>		
Stack (RTS)	<b>RTS</b>	60	x	x	x	1	6

## Subtract with Borrow from Accumulator

**SBC**

Subtract the data located at the effective address specified by the operand from the contents of the accumulator; subtract one more if the carry flag is clear, and store the result in the accumulator.

The 65x processors have no subtract instruction that does not involve the carry. To avoid subtracting the carry flag from the result, either you must be sure it is set or you must explicitly set it (using **SEC**) prior to executing the **SBC** instruction.

In a multi-precision (multi-word) subtract, you set the carry before the low words are subtracted. The low word subtraction generates a new carry flag value based on the subtraction. The carry is set if no borrow was required and cleared if borrow was required. The complement of the new carry flag (one if the carry is clear) is subtracted during the next subtraction, and so on. Each result thus correctly reflects the borrow from the previous subtraction.

Note that this use of the carry flag is the opposite of the way the borrow flag is used by some other processors, which clear (not set) the carry if no borrow was required.

**d flag clear:** Binary subtraction is performed.

**d flag set:** Binary coded decimal (BCD) subtraction is performed.

**8-bit accumulator (all processors):** Data subtracted from memory is eight-bit.

**16-bit accumulator (65802/65816 only, m=0):** Data subtracted from memory is sixteen-bit: the low eight bits is located at the effective address; the high eight bits is located at the effective address plus one.

### Flags Affected:

**n v - - - z c**

**n** Set if most significant bit of result is set; else cleared.

**v** Set if signed overflow; cleared if valid sign result.

**z** Set if result is zero; else cleared.

**c** Set if unsigned borrow not required; cleared if unsigned borrow.

## The Western Design Center

### Codes:

<i>Addressing Mode</i> <sup>++</sup>	<i>Syntax</i>	<i>Opcode (hex)</i>	<i>Available to:</i>			<i># of Bytes</i>	<i># of Cycles</i>
			<i>6502</i>	<i>65C02</i>	<i>65802/816</i>		
Immediate	<b>SBC</b> # <i>const</i>	E9	x	x	x	2*	2 <sup>1,4</sup>
Absolute	<b>SBC</b> <i>addr</i>	ED	x	x	x	3	4 <sup>1,4</sup>
Absolute Long	<b>SBC</b> <i>long</i>	EF			x	4	5 <sup>1,4</sup>
Direct Page (also DP)	<b>SBC</b> <i>dp</i>	E5	x	x	x	2	3 <sup>1,2,4</sup>
DP Indirect	<b>SBC</b> ( <i>dp</i> )	F2		x	x	2	5 <sup>1,2,4</sup>
DP Indirect Long	<b>SBC</b> [ <i>dp</i> ]	E7			x	2	6 <sup>1,2,4</sup>
Absolute Indexed, X	<b>SBC</b> <i>addr</i> , <i>X</i>	FD	x	x	x	3	4 <sup>1,3,4</sup>
Absolute Long Indexed, X	<b>SBC</b> <i>long</i> , <i>X</i>	FF			x	4	5 <sup>1,4</sup>
Absolute Indexed, Y	<b>SBC</b> <i>addr</i> , <i>Y</i>	F9	x	x	x	3	4 <sup>1,3,4</sup>
DP Indexed, X	<b>SBC</b> <i>dp</i> , <i>X</i>	F5	x	x	x	2	4 <sup>1,2,3,4</sup>
DP Indexed Indirect, X	<b>SBC</b> ( <i>dp</i> , <i>X</i> )	E1	x	x	x	2	6 <sup>1,2,4</sup>
DP Indirect Indexed, Y	<b>SBC</b> ( <i>dp</i> ), <i>Y</i>	F1	x	x	x	2	5 <sup>1,2,3,4</sup>
DP Indirect Long Indexed, Y	<b>SBC</b> [ <i>dp</i> ], <i>Y</i>	F7			x	2	6 <sup>1,2,4</sup>
Stack Relative (also SR)	<b>SBC</b> <i>sr</i> , <i>S</i>	E3			x	2	4 <sup>1,4</sup>
SR Indirect Indexed, Y	<b>SBC</b> ( <i>sr</i> , <i>S</i> ), <i>Y</i>	F3			x	2	7 <sup>1,4</sup>

++ SBC, a Primary Group Instruction, has available all of the Primary Group addressing modes and bit patterns

\* Add 1 byte if m=0 (16-bit memory/accumulator)

1 Add 1 cycle if m=0 (16-bit memory/accumulator)

2 Add 1 cycle if low byte of Direct Page register is other than zero (DL<>0)

3 Add 1 cycle if adding index crosses a page boundary

4 Add 1 cycle if 65C02 and d=1 (decimal mode, 65C02)

**Set Carry Flag**

**SEC**

Set the carry flag in the status register.

**SEC** is used prior to subtraction (using the 65x's **SBC** instruction) to keep the carry flag from affecting the result, and prior to an **XCE** (exchange carry flag with emulation bit) instruction to put the 65802 or 65816 into 6502 emulation mode.

**Flags Affected:**     - - - - - c  
                           c Carry flag set always.

**Codes:**

<i>Addressing Mode</i>	<i>Syntax</i>	<i>Opcode</i>	<i>Available to:</i>			<i># of</i>	<i># of</i>
		<i>(hex)</i>	<i>6502</i>	<i>65C02</i>	<i>65802/816</i>	<i>Bytes</i>	<i>Cycles</i>
Implied	SEC	38	x	x	x	1	2

**Set Decimal Mode Flag**

**SED**

Set the decimal mode flag in the status register.

**SED** is used to shift 65x processors into decimal mode from binary mode, so that the **ADC** and **SBC** instructions will operate correctly on the BCD data, performing automatic decimal adjustment.

**Flags Affected:**     - - - - **d** - - -  
                           d Decimal mode flag set always.

**Codes:**

<i>Addressing Mode</i>	<i>Syntax</i>	<i>Opcode</i>	<i>Available to:</i>			<i># of</i>	<i># of</i>
		<i>(hex)</i>	<i>6502</i>	<i>65C02</i>	<i>65802/816</i>	<i>Bytes</i>	<i>Cycles</i>
Implied	<b>SED</b>	F8	x	x	x	1	2

**Set Interrupt Disable Flag**

**SEI**

Set the interrupt disable flag in the status register.

**SEI** is used to disable hardware interrupt processing. When the **i** bit is set, maskable hardware interrupts (**IRQ'**) are ignored. The processor itself sets the **i** flag when it begins servicing an interrupt, so interrupt handling routines that are intended to be interruptable must reenable interrupts with **CLI**. If interrupts are to remain blocked during the interrupt service, exiting the routine via **RTI** will automatically restore the status register with the **i** flag clear, re-enabling interrupts.

**Flags Affected:**     - - - - - **i** - -  
                           i Interrupt disable flag set always.

**Codes:**

<i>Addressing Mode</i>	<i>Syntax</i>	<i>Opcode</i>	<i>Available to:</i>			<i># of</i>	<i># of</i>
		<i>(hex)</i>	<i>6502</i>	<i>65C02</i>	<i>65802/816</i>	<i>Bytes</i>	<i>Cycles</i>
Implied	SEI	78	x	x	x	1	2

**Set Status Bits**

**SEP**

For each one-bit in the operand byte, set the corresponding bit in the status register to one. For example, if bit three is set in the operand byte, bit three in the status register (the decimal flag) is set to one by this instruction. Zeroes in the operand byte cause no change to their corresponding status register bits.

This instruction lets you set *any* flag or flags in the status register with a single two-byte instruction. Furthermore, it is the only direct means of setting the **m** and **x** mode select flags. (Instructions that pull the **P** status register indirectly affect the **m** and **x** mode select flags).

**6502 emulation mode (65802/65816, e=1):** Neither the break flag nor bit five (the 6502's non-flag bit) is affected by **SEP**.

**Flags Affected:**      **n v - - d i z c**      (65802/65816 emulation e=1)  
                           **n v m x d i z c**      (65802/65816 native mode e=0)  
 All flags for which an operand bit is set are set to one.  
 All other flags are unaffected by the instruction.

**Codes:**

<i>Addressing Mode</i>	<i>Syntax</i>	<i>Opcode</i>	<i>Available to:</i>			<i># of</i>	<i># of</i>
		<i>(hex)</i>	<i>6502</i>	<i>65C02</i>	<i>65802/816</i>	<i>Bytes</i>	<i>Cycles</i>
Immediate	<b>SEP # const</b>	E2			x	2	3



## Store Accumulator to Memory

STA

Store the value in the accumulator to the effective address specified by the operand.

**8-bit accumulator (all processors):** Value is eight-bit.

**16-bit accumulator (65802/65816 only, m=0):** Value is sixteen-bit: the low-order eight bits are stored to the effective address; the high-order eight bits are stored to the effective address plus one.

The 65x flags are unaffected by store instructions.

**Flags Affected:** - - - - -

**Codes:**

Addressing Mode <sup>++</sup>	Syntax	Opcode (hex)	Available on::			# of Bytes	# of Cycles
			6502	65C02	65802/816		
Absolute	STA addr	8D	x	x	x	3	4 <sup>1</sup>
Absolute Long	STA long	8F			x	4	5 <sup>1</sup>
Direct Page (also DP)	STA dp	85	x	x	x	2	3 <sup>1,2</sup>
DP Indirect	STA (dp)	92		x	x	2	5 <sup>1,2</sup>
DP Indirect Long	STA [dp]	87			x	2	6 <sup>1,2</sup>
Absolute Indexed, X	STA addr, X	9D	x	x	x	3	5 <sup>1</sup>
Absolute Long Indexed, X	STA long, X	9F			x	4	5 <sup>1</sup>
Absolute Indexed, Y	STA addr, Y	99	x	x	x	3	5 <sup>1</sup>
DP Indexed, X	STA dp, X	95	x	x	x	2	4 <sup>1,2</sup>
DP Indexed Indirect, X	STA (dp, X)	81	x	x	x	2	6 <sup>1,2</sup>
DP Indirect Indexed, Y	STA (dp), Y	91	x	x	x	2	6 <sup>1,2</sup>
DP Indirect Long Indexed, Y	STA [dp], Y	97			x	2	6 <sup>1,2</sup>
Stack Relative (also SR)	STA sr, S	83			x	2	4 <sup>1</sup>
SR Indirect Indexed, Y	STA (sr, S), Y	93			x	2	7 <sup>1</sup>

<sup>++</sup> STA, a Primary Group Instruction, has available all of the Primary Group addressing modes and bit patterns

1 Add 1 cycle if m=0 (16-bit memory/accumulator)

2 Add 1 cycle if low byte of Direct Page register is other than zero (DL<>0)

**Stop the Processor**

**STP**

During the processor's next phase 2 clock cycle, stop the processor's oscillator input; the processor is effectively shut down until a reset occurs (until the **RES'** pin is pulled low).

**STP** is designed to put the processor to sleep while it's not (actively) in use in order to reduce power consumption. Since power consumption is a function of frequency with CMOS circuits, stopping the clock cuts power to almost nil.

Your reset handling routine (pointed to by the reset vector, \$00:FFFC-FD) should be designed to either reinitialize the system or resume control through a previously-installed reset handler.

Remember that reset is an interrupt-like signal that causes the emulation bit to be set to one. It also causes the direct page register to be reset to zero; stack high to be set to one (forcing the stack pointer to page one); and the mode select flags to be set to one (eight-bit registers; a side effect is that the high bytes of the index registers are zeroed). **STP** is useful only in hardware systems (such as battery-powered systems) specifically designed to support a low-power mode.

**Flags Affected:**     - - - - -

**Codes:**

<i>Addressing Mode</i>	<i>Syntax</i>	<i>Opcode</i>	<i>Available on:</i>			<i># of</i>	<i># of</i>
		<i>(hex)</i>	<i>6502</i>	<i>65C02</i>	<i>65802/816</i>	<i>Bytes</i>	<i>Cycles</i>
Implied	STP	DB			x	1	3 <sup>1</sup>

<sup>1</sup> Uses 3 cycles to shut the processor down; additional cycles are required by reset to restart it

**Store Index Register X to Memory**

**STX**

Store the value in index register **X** to the effective address specified by the operand.

**8-bit index registers (all processors):** Value is eight-bit.

**16-bit index registers (65802/65816 only, x = 0):** Value is sixteen-bit: the low-order eight bits are stored to the effective address; the high-order eight bits are stored to the effective address plus one.

The 65x flags are unaffected by store instructions.

**Flags Affected:**     - - - - -

**Codes:**

<i>Addressing Mode</i>	<i>Syntax</i>	<i>Opcode (hex)</i>	<i>Available on:</i>			<i># of Bytes</i>	<i># of Cycles</i>
			<i>6502</i>	<i>65C02</i>	<i>65802/81 6</i>		
Absolute	<b>STX</b> <i>addr</i>	8E	x	x	x	3	4 <sup>1</sup>
Direct page	<b>STX</b> <i>dp</i>	86	x	x	x	2	3 <sup>1,2</sup>
Direct Indexed, Y	Page <b>STX</b> <i>dp,</i> <i>Y</i>	96	x	x	x	2	4 <sup>1,2</sup>

1 Add 1 cycle if x=0 (16-bit index registers)

2 Add 1 cycle if low byte of Direct Page register is other than zero (DL< >0)

**Store Index Register Y to Memory**

**STY**

Store the value in index register **Y** to the effective address specified by the operand.

**8-bit index registers (all processors):** Value is eight-bit.

**16-bit index registers (65802/65816 only, x = 0):** Value is sixteen-bit: the low-order eight bits are stored to the effective address; the high-order eight bits are stored to the effective address plus one.

The 65x flags are unaffected by store instructions.

**Flags Affected:**     - - - - -

**Codes:**

<i>Addressing Mode</i>	<i>Syntax</i>	<i>Opcode (hex)</i>	<i>Available on:</i>			<i># of Bytes</i>	<i># of Cycles</i>
			<i>6502</i>	<i>65C02</i>	<i>65802/816</i>		
Absolute	<b>STX</b> <i>addr</i>	8C	x	x	x	3	4 <sup>1</sup>
Direct page	<b>STX</b> <i>dp</i>	84	x	x	x	2	3 <sup>1,2</sup>
Direct Page Indexed, X	<b>STX</b> <i>dp,</i> <i>X</i>	94	x	x	x	2	4 <sup>1,2</sup>

1 Add 1 cycle if x=0 (16-bit index registers)

2 Add 1 cycle if low byte of Direct Page register is other than zero (DL< >0)

**Store Zero to Memory**

**STZ**

Store zero to the effective address specified by the operand.

**8-bit accumulator (all processors):** Zero is stored at the effective address.

**16-bit accumulator/memory (65802/65816 only, m = 0):** Zero is stored at the effective address and at the effective address plus one.

The 65x store zero instruction does not affect the flags.

**Flags Affected:** - - - - -

**Codes:**

<i>Addressing Mode</i>	<i>Syntax</i>	<i>Opcode (hex)</i>	<i>Available on:</i>			<i># of Bytes</i>	<i># of Cycles</i>
			<i>6502</i>	<i>65C02</i>	<i>65802/816</i>		
Absolute	<b>STZ</b> <i>addr</i>	9C		x	x	3	4 <sup>1</sup>
Direct Page	<b>STZ</b> <i>dp</i>	64		x	x	2	3 <sup>1,2</sup>
Absolute Indexed, X	<b>STZ</b> <i>addr</i> , X	9E		x	x	3	5 <sup>1</sup>
Direct Page Indexed, X	<b>STZ</b> <i>dp, X</i>	74		x	x	2	4 <sup>1,2</sup>

1 Add 1 cycle if m=0 (16-bit memory/accumulator)

2 Add 1 cycle if low byte of Direct Page register is other than zero (DL< >0)

**Transfer Accumulator to Index Register X**

**TAX**

Transfer the value in the accumulator to index register **X**. If the registers are different sizes, the nature of the transfer is determined by the destination register. The value in the accumulator is not changed by the operation.

**8-bit accumulator, 8-bit index registers (all processors):** Value transferred is eight-bit.

**8-bit accumulator, 16-bit index registers (65802/65816 only, m = 1, x = 0):** Value transferred is sixteen-bit; the eight-bit **A** accumulator becomes the low byte of the index register; the hidden eight-bit **B** accumulator becomes the high byte of the index register.

**16-bit accumulator, 8-bit index registers (65802/65816 only, m=0, x=1):** Value transferred to the eight-bit index register is eight-bit, the low byte of the accumulator.

**16-bit accumulator, 16-bit index registers (65802/65816 only, m=0, x=0):** Value transferred to the sixteen-bit index register is sixteen-bit, the full sixteen-bit accumulator.

**Flags Affected:**

**n - - - - z -**

n Set if most significant bit of transferred value is set; else cleared.

z Set if value transferred is zero; else cleared.

**Codes:**

<i>Addressing Mode</i>	<i>Syntax</i>	<i>Opcode</i>		<i>Available to:</i>			<i># of</i>	<i># of</i>
		<i>(hex)</i>	<i>6502</i>	<i>65C02</i>	<i>65802/816</i>	<i>Bytes</i>	<i>Cycles</i>	
Implied	<b>TAX</b>	AA	x	x	x	1	2	

**Transfer Accumulator to Index Register Y**

**TAY**

Transfer the value in the accumulator to index register **Y**. If the registers are different sizes, the nature of the transfer is determined by the destination register. The value in the accumulator is not changed by the operation.

**8-bit accumulator, 8-bit index registers (all processors):** Value transferred is eight-bit.

**8-bit accumulator, 16-bit index registers (65802/65816 only, m = 1, x = 0):** Value transferred is sixteen-bit; the eight-bit **A** accumulator becomes the low byte of the index register; the hidden eight-bit **B** accumulator becomes the high byte of the index register.

**16-bit accumulator, 8-bit index registers (65802/65816 only, m=0, x=1):** Value transferred to the eight-bit index register is eight-bit, the low byte of the accumulator.

**16-bit accumulator, 16-bit index registers (65802/65816 only, m=0, x=0):** Value transferred to the sixteen-bit index register is sixteen-bit, the full sixteen-bit accumulator.

**Flags Affected:**

**n - - - - z -**

n Set if most significant bit of transferred value is set; else cleared.

z Set if value transferred is zero; else cleared.

**Codes:**

<i>Addressing Mode</i>	<i>Syntax</i>	<i>Opcode (hex)</i>	<i>Available to:</i>			<i># of Bytes</i>	<i># of Cycles</i>
			<i>6502</i>	<i>65C02</i>	<i>65802/816</i>		
Implied	<b>TAX</b>	AA	x	x	x	1	2

**Transfer 16-Bit Accumulator to Direct Page Register**

**TCD**

Transfer the value in the sixteen-bit accumulator **C** to the direct page register **D**, regardless of the setting of the accumulator/memory mode flag.

An alternate mnemonic is **TAD**, (transfer the value in the **A** accumulator to the direct page register).

In **TCD**, the “**C**” is used to indicate that sixteen bits are transferred regardless of the **m** flag. If the **A** accumulator is set to just eight bits (whether because the **m** flag is set, or because the processor is in 6502 emulation mode), then its value becomes the low byte of the direct page register and the value in the hidden **B** accumulator becomes the high byte of the direct page register.

The accumulator’s sixteen-bit value is unchanged by the operation.

**Flags Affected:**

**n - - - - z -**

**n** Set if most significant bit of transferred value is set; else cleared.

**z** Set if value transferred is zero; else cleared.

**Codes:**

<i>Addressing Mode</i>	<i>Syntax</i>	<i>Opcode</i>	<i>Available to:</i>			<i># of</i>	<i># of</i>
		<i>(hex)</i>	<i>6502</i>	<i>65C02</i>	<i>65802/816</i>	<i>Bytes</i>	<i>Cycles</i>
Implied	TCD (or TAD)	5B			x	1	2



**Transfer Accumulator to Stack Pointer**

**TCS**

Transfer the value in the accumulator to the stack pointer **S**. The accumulator's value is unchanged by the operation.

An alternate mnemonic is **TAS** (transfer the value in the **A** accumulator to the stack pointer).

In **TCS**, the "C" is used to indicate that, in native mode, sixteen bits are transferred regardless of the **m** flag. If the **A** accumulator is set to just eight bits (because the **m** flag is set), then its value is transferred to the low byte of the stack pointer and the value in the hidden **B** accumulator is transferred to the high byte of the stack pointer. In emulation mode, only the eight-bit **A** accumulator is transferred, since the high stack pointer byte is forced to one (the stack is confined to page one).

**TCS**, along with **TXS**, are the only two instructions for changing the value in the stack pointer. The two are also the only two transfer instructions not to alter the flags.

**Flags Affected:**     - - - - -

**Codes:**

<i>Addressing Mode</i>	<i>Syntax</i>	<i>Opcode</i>	<i>Available to:</i>			<i># of</i>	<i># of</i>
		<i>(hex)</i>	<i>6502</i>	<i>65C02</i>	<i>65802/816</i>	<i>Bytes</i>	<i>Cycles</i>
Implied	TCS (or TAS)	1B			x	1	2

**Transfer Direct Page Register to 16-Bit Accumulator**

**TDC**

Transfer the value in the sixteen-bit direct page register **D** to the sixteen-bit accumulator **C**, regardless of the setting of the accumulator/memory mode flag.

An alternate mnemonic is **TDA** (transfer the value in the direct page register to the **A** accumulator).

In **TDC**, the “**C**” is used to indicate that sixteen bits are transferred regardless of the **m** flag. If the **A** accumulator is set to just eight bits (whether because the **m** flag is set, or because the processor is in 6502 emulation mode), then it takes the value of the low byte of the direct page register and the hidden **B** accumulator takes the value of the high byte of the direct page register.

The direct page register’s sixteen-bit value is unchanged by the operation.

**Flags Affected:**      **n - - - - z -**

n Set if most significant bit of transferred value is set; else cleared.

z Set if value transferred is zero; else cleared.

**Codes:**

<i>Addressing Mode</i>	<i>Syntax</i>	<i>Opcode</i>		<i>Available to:</i>			<i># of</i>	<i># of</i>
		<i>(hex)</i>	<i>6502</i>	<i>65C02</i>	<i>65802/816</i>	<i>Bytes</i>	<i>Cycles</i>	
Implied	TDC (or TDA)	7B			x	1	2	

**Test and Reset Memory Bits Against Accumulator**

**TRB**

Logically AND together the *complement* of the value in the accumulator with the data at the effective address specified by the operand. Store the result at the memory location.

This has the effect of clearing each memory bit for which the corresponding accumulator bit is set, while leaving unchanged all memory bits in which the corresponding accumulator bits are zeroes.

Unlike the **BIT** instruction, **TRB** is a read-modify-write instruction, not only calculating a result and modifying a flag, but also storing the result to memory as well.

The **z** zero flag is set based on a second and *different* operation the ANDing of the accumulator value (not its complement) with the memory value (the same way the **BIT** instruction affects the zero flag). The result of this second operation is not saved; only the zero flag is affected by it.

**8-bit accumulator/memory (65C02;65802/65816, m=1):** Values in accumulator and memory are eight-bit.

**16-bit accumulator/memory(65C02;65802/65816, m=1):** Values in accumulator and memory are sixteen-bit: the low-order eight bits are located at the effective address; the high-order eight bits are at the effective address plus one.

**Flags Affected:**

- - - - - **z** -

**z** Set if memory value AND'ed with accumulator value is zero; else cleared.

**Codes:**

Addressing Mode	Syntax	Opcode	Available on:			# of Bytes	# of Cycles
		(hex)	6502	65C02	65802/816		
Absolute	<b>TRB</b> <i>addr</i>	1C		x	x	3	6 <sup>1</sup>
Direct Page	<b>TRB</b> <i>dp</i>	14		x	x	2	5 <sup>1,2</sup>

1 Add 2 cycles if m = 0 (16-bit memory/accumulator)

2 Add 1 cycle if low byte of Direct Page register is other than zero (DL<>0)

**Test and Set Memory Bits Against Accumulator**

**TSB**

Logically OR together the value in the accumulator with the data at the effective address specified by the operand. Store the result at the memory location.

This has the effect of setting each memory bit for which the corresponding accumulator bit is set, while leaving unchanged all memory bits in which the corresponding accumulator bits are zeroes.

Unlike the **BIT** instruction, **TSB** is a read-modify-write instruction, not only calculating a result and modifying a flag, but storing the result to memory as well.

The **z** zero flag is set based on a second *different* operation, the *ANDing* of the accumulator value with the memory value (the same way the **BIT** instruction affects the zero flag). The result of this second operation is not saved; only the zero flag is affected by it.

**8-bit accumulator/memory(65C02;65802/65816, m = 1):** Values in accumulator and memory are eight-bit.

**16-bit accumulator/memory (65802/65816 only, m = 0):** Values in accumulator and memory are sixteen-bit: the low-order eight bits are located at the effective address; the high-order eight bits are at the effective address plus one.

**Flags Affected:**

- - - - - **z** -

z Set if memory value AND'ed with accumulator value is zero; else cleared.

**Codes:**

Addressing Mode	Syntax	Opcode	Available on:			# of	# of
		(hex)	6502	65C02	65802/816	Bytes	Cycles
Absolute	TSB <i>addr</i>	0C		x	x	3	6 <sup>1</sup>
Direct Page	TSB <i>dp</i>	04		x	x	2	5 <sup>1,2</sup>

1 Add 2 cycles if m = 0 (16-bit memory/accumulator)

2 Add 1 cycle if low byte of Direct Page register is other than zero (DL<>0)

**Transfer Stack Pointer to 16-Bit Accumulator**

**TSC**

Transfer the value in the sixteen-bit stack pointer **S** to the sixteen-bit accumulator **C**, regardless of the setting of the accumulator/memory mode flag.

An alternate mnemonic is **TSA** (transfer the value in the stack pointer to the **A** accumulator).

In **TSC**, the “**C**” is used to indicate that sixteen bits are transferred regardless of the **m** flag. If the **A** accumulator is set to just eight bits (whether because the **m** flag is set, or because the processor is in 6502 emulation mode), then it takes the value of the low byte of the stack pointer and the hidden **B** accumulator takes the value of the high byte of the stack pointer. (In emulation mode, **B** will always take a value of one, since the stack is confined to page one.)

The stack pointer’s value is unchanged by the operation.

**Flags Affected:**      **n - - - - z -**  
                           **n** Set if most significant bit of transferred value is set; else cleared.  
                           **z** Set if value transferred is zero; else cleared.

**Codes:**

<i>Addressing Mode</i>	<i>Syntax</i>	<i>Opcode</i>	<i>Available to:</i>			<i># of</i>	<i># of</i>
		<i>(hex)</i>	<i>6502</i>	<i>65C02</i>	<i>65802/816</i>	<i>Bytes</i>	<i>Cycles</i>
Implied	TSC (or TSA)	3B			x	1	2

**Transfer Stack Pointer to Index Register X**

**TSX**

Transfer the value in the stack pointer **S** to index register **X**. The stack pointer's value is not changed by the operation.

**8-bit index registers (all processors):** Only the low byte of the value in the stack pointer is transferred to the **X** register. In the 6502, the 65C02, and the 6502 emulation mode, the stack pointer and the index registers are only a single byte each, so the byte in the stack pointer is transferred to the eight-bit **X** register. In 65802/65816 native mode, the stack pointer is sixteen bits, so its most significant byte is not transferred if the index registers are in eight-bit mode.

**16-bit index registers (65802/65816 only, x=0):** The full sixteen-bit value in the stack pointer is transferred to the **X** register.

**Flags Affected:**

**n - - - - z -**

n Set if most significant bit of transferred value is set; else cleared.

z Set if value transferred is zero; else cleared.

**Codes:**

Addressing Mode	Syntax	Opcode	Available to:			# of	# of
		(hex)	6502	65C02	65802/816	Bytes	Cycles
Implied	TSX	BA	x	x	x	1	2

**Transfer Index Register X to Accumulator**

**TXA**

Transfer the value in index register **X** to the accumulator. If the registers are different sizes, the nature of the transfer is determined by the destination (the accumulator). The value in the index register is not changed by the operation.

**8-bit index registers, 8-bit accumulator (all processors):** Value transferred is eight-bit.

**16-bit index registers, 8-bit accumulator (65802/65816 only, x=0, m=1):** Value transferred to the eight-bit accumulator is eight-bit, the low byte of the index register; the hidden eight-bit accumulator **B** is not affected by the transfer.

**8-bit index registers, 16-bit accumulator (65802/65816 only, x=1, m=0):** The eight-bit index register becomes of the low byte of the accumulator; the high accumulator byte is zeroed.

**16-bit index registers, 16-bit accumulator (65802/65816 only, x=0, m=0):** Value transferred to the sixteen-bit accumulator is sixteen-bit, the full sixteen-bit index register.

**Flags Affected:**

**n - - - - z -**

n Set if most significant bit of transferred value is set; else cleared.

z Set if value transferred is zero; else cleared.

**Codes:**

<i>Addressing Mode</i>	<i>Syntax</i>	<i>Opcode</i>		<i>Available to:</i>			<i># of</i>	<i># of</i>
		<i>(hex)</i>	<i>6502</i>	<i>65C02</i>	<i>65802/816</i>	<i>Bytes</i>	<i>Cycles</i>	
Implied	TXA	8A	x	x	x	1	2	

**Transfer Index Register X to Stack Pointer**

**TXS**

Transfer the value in index register **X** to the stack pointer, **S**. The index register's value is not changed by the operation.

**TXS**, along with **TCS**, are the only two instructions for changing the value in the stack pointer. The two are also the only two transfer instructions that do not alter the flags.

**6502, 65C02, and 6502 emulation mode (65802/65816, e=1):** The stack pointer is only eight bits (it is concatenated to a high byte of one, confining the stack to page one), and the index registers are only eight bits. The byte in **X** is transferred to the eight-bit stack pointer.

**8-bit index registers (65802/65816 native mode, x=1):** The stack pointer is sixteen bits but the index registers are only eight bits. A copy of the byte in **X** is transferred to the low stack pointer byte and the high stack pointer byte is zeroed.

**16-bit index registers (65802/65816 native mode, x=0):** The full sixteen-bit value in **X** is transferred to the sixteen-bit stack pointer.

**Flags Affected:**     - - - - -

**Codes:**

<i>Addressing Mode</i>	<i>Syntax</i>	<i>Opcode</i>	<i>Available to:</i>			<i># of</i>	<i># of</i>
		<i>(hex)</i>	<i>6502</i>	<i>65C02</i>	<i>65802/816</i>	<i>Bytes</i>	<i>Cycles</i>
Implied	TXS	9A	x	x	x	1	2



**Transfer Index Register X to Y**

**TXY**

Transfer the value in index register **X** to index register **Y**. The value in index register **X** is not changed by the operation. Note that the two registers are never different sizes.

**8-bit index registers (x=1):** Value transferred is eight-bit.

**16-bit index registers (x=0):** Value transferred is sixteen-bit.

**Flags Affected:**

**n** - - - - **z** -

n Set if most significant bit of transferred value is set; else cleared.

z Set if value transferred is zero; else cleared.

**Codes:**

<i>Addressing Mode</i>	<i>Syntax</i>	<i>Opcode</i>		<i>Available to:</i>		<i># of</i>	<i># of</i>
		<i>(hex)</i>	<i>6502</i>	<i>65C02</i>	<i>65802/816</i>	<i>Bytes</i>	<i>Cycles</i>
Implied	TXY	9B			x	1	2

**Transfer Index Register Y to Accumulator**

**TYA**

Transfer the value in index register **Y** to the accumulator. If the registers are different sizes, the nature of the transfer is determined by the destination (the accumulator). The value in the index register is not changed by the operation.

**8-bit index registers, 8-bit accumulator (all processors):** Value transferred is eight-bit.

**16-bit index registers, 8-bit accumulator (65802/65816 only, x=0, m=1):** Value transferred to the eight-bit accumulator is eight-bit, the low byte of the index register; the hidden eight-bit accumulator **B** is not affected by the transfer.

**8-bit index registers, 16-bit accumulator (65802/65816 only, x=1, m=0):** The eight-bit index register becomes of the low byte of the accumulator; the high accumulator byte is zeroed.

**16-bit index registers, 16-bit accumulator (65802/65816 only, x=0, m=0):** Value transferred to the sixteen-bit accumulator is sixteen-bit, the full sixteen-bit index register.

**Flags Affected:**

**n - - - - z -**

n Set if most significant bit of transferred value is set; else cleared.

z Set if value transferred is zero; else cleared.

**Codes:**

<i>Addressing Mode</i>	<i>Syntax</i>	<i>Opcod</i>	<i>Available to:</i>			<i># of</i>	<i># of</i>
		<i>e</i>				<i>Bytes</i>	<i>Cycles</i>
		<i>(hex)</i>	<i>6502</i>	<i>65C02</i>	<i>65802/816</i>		
Implied	TYA	98	x	x	x	1	2

**Transfer Index register Y to X**

**TYX**

Transfer the value in index register **Y** to index register **X**. The value in index register **Y** is not changed by the operation. Note that the two registers are never different sizes.

**8-bit index registers (x=1):** Value transferred is eight-bit.

**16-bit index registers (x=0):** Value transferred is sixteen-bit.

**Flags Affected:**     **n - - - - z -**

n Set if most significant bit of transferred value is set; else cleared.

z Set if value transferred is zero; else cleared.

**Codes:**

<i>Addressing Mode</i>	<i>Syntax</i>	<i>Opcode</i>		<i>Available to:</i>			<i># of</i>	<i># of</i>
		<i>(hex)</i>	<i>6502</i>	<i>65C02</i>	<i>65802/816</i>	<i>Bytes</i>	<i>Cycles</i>	
Implied	TYX	BB			x	1	2	

**Wait for Interrupt**

**WAI**

Pull the **RDY** pin low. Power consumption is reduced and **RDY** remains low until an external hardware interrupt (**NMI**, **IRQ**, **ABORT**, or **RESET**) is received.

**WAI** is designed to put the processor to sleep during an external event to reduce its power consumption, to allow it to be synchronized with an external event, and/or to reduce interrupt latency (an interrupt occurring *during* execution of an instruction is not acted upon until execution of the instruction is complete, perhaps many cycles later; **WAI** ensures that an interrupt is recognized immediately).

Once an interrupt is received, control is vectored through one of the hardware interrupt vectors; an **RTI** from the interrupt handling routine will return control to the instruction following the original **WAI**. However, if by setting the **i** flag, interrupt have been disabled prior to the execution of the **WAI** instruction, and **IRQ'** is asserted, the “wait” condition is terminated and control resumes with the next instruction, rather than through the interrupt vectors. This provides the quickest response to an interrupt, allowing synchronization with external events. **WAI** also frees up the bus; since **RDY** is pulled low in the third instruction cycle, the processor may be disconnected from the bus if **BE** is also pulled low.

**Flags Affected:**     - - - - -

**Codes:**

<i>Addressing Mode</i>	<i>Syntax</i>	<i>Opcode</i>		<i>Available to:</i>			<i># of</i>	<i># of</i>
		<i>(hex)</i>	<i>6502</i>	<i>65C02</i>	<i>65802/816</i>	<i>Bytes</i>	<i>Cycles</i>	
Implied	<b>WAI</b>	CB			x	1	3 <sup>1</sup>	

1 Uses 3 cycles to shut the processor down; additional cycles are required by interrupt to restart it

**Reserved for Future Expansion**

**WDM**

The 65802 and 65816 use 255 of the 256 possible eight-bit opcodes. One was reserved; it provides an “escape hatch” for future 65x processors to expand their instruction set to sixteen bit opcodes; this opcode would signal that the next byte is an opcode in the expanded instruction set. This reserved byte for future two-byte opcodes was given a temporary mnemonic, **WDM**, which happen to be the initials of the processors’ designer – William D. Mensch, Jr.

**WDM** should never be used in a program, since it would render the object program incompatible with any future 65x processors.

If the 65802/65816 **WDM** instruction is accidentally executed, it will act like a two-byte **NOP** instruction.

**Flags Affected\*:**     - - - - -

\* Flags will be affected variously by future two-byte instructions.

**Codes:**

<i>Addressing Mode</i>	<i>Syntax</i>	<i>Opcode</i>		<i>Available to:</i>		<i># of</i>	<i># of</i>
		<i>(hex)</i>	<i>6502</i>	<i>65C02</i>	<i>65802/816</i>	<i>Bytes</i>	<i>Cycles</i>
	<b>WDM</b>	42			x	2*	*

\* Byte and cycle counts subject to change in future processors which expand WDM into 2-byte opcode portions of instructions of varying lengths

**Exchange the B and A Accumulators**

**XBA**

**B** represents the high-order byte of the sixteen-bit **C** accumulator, and **A** in this case represents the low-order byte. **XBA** swaps the contents of the low-order and high-order bytes of **C**.

An alternate mnemonic is **SWA** (swap the high and low bytes of the sixteen-bit **A** accumulator).

**XBA** can be used to invert the low-order, high-order arrangement of a sixteen-bit value, or to temporarily store an eight-bit value from the **A** accumulator into **B**. Since it is an exchange, the previous contents of both accumulators are changed, replaced by the previous contents of the other.

Neither the mode select flags nor the emulation mode flag affects this operation.

The flags are changed based on the new value of the low byte, the **A** accumulator (that is, on the former value of the high byte, the **B** accumulator), even in sixteen-bit accumulator mode.

**Flags Affected:**

**n** - - - - **z** -

**n** Set if most significant bit of new 8-bit value A accumulator is set; else cleared.

**z** Set if new 8-bit value in A accumulator is zero; else cleared.

**Codes:**

<i>Addressing Mode</i>	<i>Syntax</i>	<i>Opcode</i>	<i>Available to:</i>			<i># of</i>	<i># of</i>
		<i>(hex)</i>	<i>6502</i>	<i>65C02</i>	<i>65802/816</i>	<i>Bytes</i>	<i>Cycles</i>
Implied	XBA (or SWA)	EB			x	1	3

**Exchange Carry and Emulation Bits**

**XCE**

This instruction is the only means provided by the 65802 and 65816 to shift between 6502 emulation mode and the full, sixteen-bit native mode.

The emulation mode is used to provide hardware and software compatibility between the 6502 and 65802/65816.

If the processor is in emulation mode, then to switch to native mode, first clear the carry bit, then execute an **XCE**. Since it is an exchange operation, the carry flag will reflect the previous state of the emulation bit. Switching to native mode causes bit five to stop functioning as the break flag, and function instead as the **x** mode select flag. A second mode select flag, **m**, uses bit six, which was unused in emulation mode. Both mode select flags are initially set to one (eight-bit modes). There are also other differences described in the text.

If the processor is in native mode, then to switch to emulation mode, you first set the carry bit, then execute an **XCE**. Switching to emulation mode causes the mode select flags (**m** and **x**) to be lost from the status register, with **x** replaced by the **b** break flag. This forces the accumulator to eight bits, but the high accumulator byte is preserved in the hidden **B** accumulator. It also forces the index registers to eight bits, causing the loss of values in their high bytes, and the stack to page one, causing the loss of the high byte of the previous stack address. There are also other differences described in the text.

- Flags Affected:**
- - **m** **b/x** - - - **c** **e**
  - e Takes carry's previous value: set if carry was set; else cleared.
  - c Takes emulation's pervious value: set if previous mode was emulation; else cleared.
  - m m is a native mode flag only; switching to native mode sets it to 1.
  - x x is a native mode flag only; it becomes the b flag in emulation.
  - b b is an emulation mode flag only; it is set to 1 to become the x flag in native.

**Codes:**

<i>Addressing Mode</i>	<i>Syntax</i>	<i>Opcode (hex)</i>	<i>Available to:</i>			<i># of Bytes</i>	<i># of Cycles</i>
			<i>6502</i>	<i>65C02</i>	<i>65802/816</i>		
Implied	XCE	FB			x	1	2

# 19) Chapter Nineteen

## Instruction Lists

<i>Opcode</i>			<i>Available on:</i>			<i># of</i>	<i># of</i>
<i>Hex</i>	<i>Mnemonic</i>	<i>Addressing Mode</i>	<i>6502</i>	<i>65C02</i>	<i>65802/816</i>	<i>Bytes</i>	<i>Cycles</i>
00	BRK	Stack/Interrupt	x	x	x	2**	7 <sup>9</sup>
01	ORA	DP Indexed Indirect, X	x	x	x	2	6 <sup>1,2</sup>
02	COP	Stack/Interrupt			x	2**	7 <sup>9</sup>
03	ORA	Stack Relative			x	2	4 <sup>1</sup>
04	TSB	Direct Page		x	x	2	5 <sup>2,5</sup>
05	ORA	Direct Page	x	x	x	2	3 <sup>1,2</sup>
06	ASL	Direct Page	x	x	x	2	5 <sup>2,5</sup>
07	ORA	DP Indirect Long			x	2	6 <sup>1,2</sup>
08	PHP	Stack (Push)	x	x	x	1	3
09	ORA	Immediate	x	x	x	2*	2 <sup>1</sup>
0A	ASL	Accumulator	x	x	x	1	2
0B	PHD	Stack (Push)			x	1	4
0C	TSB	Absolute		x	x	3	6 <sup>5</sup>
0D	ORA	Absolute	x	x	x	3	4 <sup>1</sup>
0E	ASL	Absolute	x	x	x	3	6 <sup>5</sup>
0F	ORA	Absolute Long			x	4	5 <sup>1</sup>
10	BLP	Program Counter Relative	x	x	x	2	2 <sup>7,8</sup>
11	ORA	DP Indirect Indexed, Y	x	x	x	2	5 <sup>1,2,3</sup>
12	ORA	DP Indirect		x	x	2	5 <sup>1,2</sup>
13	ORA	SR Indirect Indexed, Y			x	2	7 <sup>1</sup>
14	TRB	Direct Page		x	x	2	5 <sup>2,5</sup>
15	ORA	DP Indexed, X	x	x	x	2	4 <sup>1,2</sup>
16	ASL	DP Indexed, X	x	x	x	2	6 <sup>2,5</sup>
17	ORA	DP Indirect Long Indexed, Y			x	2	6 <sup>1,2</sup>
18	CLC	Implied	x	x	x	1	2
19	ORA	Absolute Indexed, Y	x	x	x	3	4 <sup>1,3</sup>
1A	INC	Accumulator		x	x	1	2
1B	TCS	Implied			x	1	2
1C	TRB	Absolute		x	x	3	6 <sup>5</sup>
1D	ORA	Absolute Indexed, X	x	x	x	3	4 <sup>1,3</sup>
1E	ASL	Absolute Indexed, X	x	x	x	3	7 <sup>5,6</sup>
1F	ORA	Absolute Long Indexed, X			x	4	5 <sup>1</sup>
20	JSR	Absolute	x	x	x	3	6
21	AND	DP Indexed Indirect, X	x	x	x	2	6 <sup>1,2</sup>
22	JSR	Absolute Long			x	4	8
23	AND	Stack Relative			x	2	4 <sup>1</sup>
24	BIT	Direct Page	x	x	x	2	3 <sup>1,2</sup>
25	AND	Direct Page	x	x	x	2	3 <sup>1,2</sup>
26	ROL	Direct Page	x	x	x	2	5 <sup>2,5</sup>
27	AND	DP Indirect Long			x	2	6 <sup>1,2</sup>
28	PLP	Stack (Pull)	x	x	x	1	4
29	AND	Immediate	x	x	x	2*	2 <sup>1</sup>
2A	ROL	Accumulator	x	x	x	1	2
2B	PLD	Stack (Pull)			x	1	5
2C	BIT	Absolute	x	x	x	3	4 <sup>1</sup>
2D	AND	Absolute	x	x	x	3	4 <sup>1</sup>

*Continued.*



## The Western Design Center

<i>Opcode</i>			<i>Available on:</i>			<i># of</i>	<i># of</i>
<i>Hex</i>	<i>Mnemonic</i>	<i>Addressing Mode</i>	<i>6502</i>	<i>65C02</i>	<i>65802/816</i>	<i>Bytes</i>	<i>Cycles</i>
2E	ROL	Absolute	x	x	x	3	6 <sup>5</sup>
2F	AND	Absolute Long			x	4	5 <sup>1</sup>
30	BMI	Program Counter Relative	x	x	x	2	2 <sup>7,8</sup>
31	AND	DP Indirect Indexed, Y	x	x	x	2	5 <sup>1,2,3</sup>
32	AND	DP Indirect		x	x	2	5 <sup>1,2</sup>
33	AND	SR Indirect Indexed, Y			x	2	7 <sup>1</sup>
34	BIT	DP Indexed, X		x	x	2	4 <sup>1,2</sup>
35	AND	DP Indexed, X	x	x	x	2	4 <sup>1,2</sup>
36	ROL	DP Indexed, X	x	x	x	2	6 <sup>2,5</sup>
37	AND	DP Indirect Long Indexed, Y			x	2	6 <sup>1,2</sup>
38	SEC	Implied	x	x	x	1	2
39	AND	Absolute Indexed, Y	x	x	x	3	4 <sup>1,3</sup>
3A	DEC	Accumulator		x	x	1	2
3B	TSC	Implied			x	1	2
3C	BIT	Absolute Indexed, X		x	x	3	4 <sup>1,3</sup>
3D	AND	Absolute Indexed, X	x	x	x	3	4 <sup>1,3</sup>
3E	ROL	Absolute Indexed, x	x	x	x	3	7 <sup>5,6</sup>
3F	AND	Absolute Long Indexed, X			x	4	5 <sup>1</sup>
40	RTI	Stack/RTI	x	x	x	1	6 <sup>9</sup>
41	EOR	DP Indexed Indirect, X	x	x	x	2	6 <sup>1,2</sup>
42	WDM				x	2 <sup>16</sup>	16
43	EOR	Stack Relative			x	2	4 <sup>1</sup>
44	MVP	Block Move			x	3	13
45	EOR	Direct Page	x	x	x	2	3 <sup>1,2</sup>
46	LSR	Direct Page	x	x	x	2	5 <sup>2,5</sup>
47	EOR	DP Indirect Long			x	2	6 <sup>1,2</sup>
48	PHA	Stack (Push)	x	x	x	1	3 <sup>1</sup>
49	EOR	Immediate	x	x	x	2*	2 <sup>1</sup>
4A	LSR	Accumulator	x	x	x	1	2
4B	PHK	Stack (Push)			x	1	3
4C	JMP	Absolute	x	x	x	3	3
4D	EOR	Absolute	x	x	x	3	4 <sup>1</sup>
4E	LSR	Absolute	x	x	x	3	6 <sup>5</sup>
4F	EOR	Absolute Long			x	4	5 <sup>1</sup>
50	BVC	Program Counter Relative	x	x	x	2	2 <sup>7,8</sup>
51	EOR	DP Indirect Indexed, Y	x	x	x	2	5 <sup>1,2,3</sup>
52	EOR	DP Indirect		x	x	2	5 <sup>1,2</sup>
53	EOR	SR Indirect Indexed, Y			x	2	7 <sup>1</sup>
54	MVN	Block Move			x	3	13
55	EOR	DP Indexed, X	x	x	x	2	4 <sup>1,2</sup>
56	LSR	DP Indexed, X	x	x	x	2	6 <sup>2,5</sup>
57	EOR	DP Indirect Long Indexed, Y			x	2	6 <sup>1,2</sup>
58	CLI	Implied	x	x	x	1	2
59	EOR	Absolute Indexed, Y	x	x	x	3	4 <sup>1,3</sup>
5A	PHY	Stack (Push)		x	x	1	3 <sup>10</sup>
5B	TCD	Implied			x	1	2
5C	JMP	Absolute Long			x	4	4
5D	EOR	Absolute Indexed, X	x	x	x	3	4 <sup>1,3</sup>
5E	LSR	Absolute Indexed, X	x	x	x	3	7 <sup>5,6</sup>
5F	EOR	Absolute Long Indexed, X			x	4	5 <sup>1</sup>

*Continued.*

## The Western Design Center

<i>Opcode</i>			<i>Available on:</i>			<i># of Bytes</i>	<i># of Cycles</i>
<i>Hex</i>	<i>Mnemonic</i>	<i>Addressing Mode</i>	<i>6502</i>	<i>65C02</i>	<i>65802/816</i>		
60	RTS	Stack (RTS)	x	x	x	1	6
61	ADC	DP Indexed Indirect, X	x	x	x	2	6 <sup>1,2,4</sup>
62	PER	Stack (PC Relative Long)			x	3	6
63	ADC	Stack Relative			x	2	4 <sup>1,4</sup>
64	STZ	Direct Page		x	x	2	3 <sup>1,2</sup>
65	ADC	Direct Page	x	x	x	2	3 <sup>1,2,4</sup>
66	ROR	Direct Page	x	x	x	2	5 <sup>2,5</sup>
67	ADC	DP Indirect Long			x	2	6 <sup>1,2,4</sup>
68	PLA	Stack (Pull)	x	x	x	1	4 <sup>1</sup>
69	ADC	Immediate	x	x	x	2*	2 <sup>1,4</sup>
6A	ROR	Accumulator	x	x	x	1	2
6B	RTL	Stack (RTL)			x	1	6
6C	JMP	Absolute Indirect	x	x	x	3	5 <sup>11,12</sup>
6D	ADC	Absolute	x	x	x	3	4 <sup>1,4</sup>
6E	ROR	Absolute	x	x	x	3	6 <sup>5</sup>
6F	ADC	Absolute Long			x	4	5 <sup>1,4</sup>
70	BVS	Program Counter Relative	x	x	x	2	2 <sup>7,8</sup>
71	ADC	DP Indirect Indexed, Y	x	x	x	2	5 <sup>1,2,3,4</sup>
72	ADC	DP Indirect		x	x	2	5 <sup>1,2,4</sup>
73	ADC	SR Indirect Indexed, Y			x	2	7 <sup>1,4</sup>
74	STZ	Direct Page Indexed, X		x	x	2	4 <sup>1,2</sup>
75	ADC	DP Indexed, X	x	x	x	2	4 <sup>1,2,4</sup>
76	ROR	DP Indexed, X	x	x	x	2	6 <sup>2,5</sup>
77	ADC	DP Indirect Long Indexed, Y			x	2	6 <sup>1,2,4</sup>
78	SEI	Implied	x	x	x	1	2
79	ADC	Absolute Indexed, Y	x	x	x	3	4 <sup>1,3,4</sup>
7A	PLY	Stack/Pull		x	x	1	4 <sup>10</sup>
7B	TDC	Implied			x	1	2
7C	JMP	Absolute Indexed Indirect		x	x	3	6
7D	ADC	Absolute Indexed, X	x	x	x	3	4 <sup>1,3,4</sup>
7E	ROR	Absolute Indexed, X	x	x	x	3	7 <sup>5,6</sup>
7F	ADC	Absolute Long Indexed, X			x	4	5 <sup>1,4</sup>
80	BRA	Program Counter Relative		x	x	2	3 <sup>8</sup>
81	STA	DP Indexed Indirect, X	x	x	x	2	6 <sup>1,2</sup>
82	BRL	Program Counter Relative Long			x	3	4
83	STA	Stack Relative			x	2	4 <sup>1</sup>
84	STY	Direct Page	x	x	x	2	3 <sup>2,10</sup>
85	STA	Direct Page	x	x	x	2	3 <sup>1,2</sup>
86	STX	Direct Page	x	x	x	2	3 <sup>2,10</sup>
87	STA	DP Indirect Long			x	2	6 <sup>1,2</sup>
88	DEY	Implied	x	x	x	1	2
89	BIT	Immediate		x	x	2*	2 <sup>1</sup>
8A	TXA	Implied	x	x	x	1	2
8B	PHB	Stack (Push)			x	1	3
8C	STY	Absolute	x	x	x	3	4 <sup>10</sup>
8D	STA	Absolute	x	x	x	3	4 <sup>1</sup>
8E	STX	Absolute	x	x	x	3	4 <sup>10</sup>
8F	STA	Absolute Long			x	4	5 <sup>1</sup>
90	BCC	Program Counter Relative	x	x	x	2	2 <sup>7,8</sup>
91	STA	DP Indirect Indexed, Y	x	x	x	2	6 <sup>1,2</sup>

*Continued.*

## The Western Design Center

<i>Opcode</i>			<i>Available on:</i>			<i># of</i>	<i># of</i>
<i>Hex</i>	<i>Mnemonic</i>	<i>Addressing Mode</i>	<i>6502</i>	<i>65C02</i>	<i>65802/816</i>	<i>Bytes</i>	<i>Cycles</i>
92	STA	DP Indirect		x	x	2	5 <sup>1,2</sup>
93	STA	SR Indirect Indexed, Y			x	2	7 <sup>1</sup>
94	STY	Direct Page Indexed, X	x	x	x	2	4 <sup>2,10</sup>
95	STA	DP Indexed, X	x	x	x	2	4 <sup>1,2</sup>
96	STX	Direct Page Indexed, Y	x	x	x	2	4 <sup>2,10</sup>
97	STA	DP Indirect Long Indexed, Y			x	2	6 <sup>1,2</sup>
98	TYA	Implied	x	x	x	1	2
99	STA	Absolute Indexed, Y	x	x	x	3	5 <sup>1</sup>
9A	TXS	Implied	x	x	x	1	2
9B	TXY	Implied			x	1	2
9C	STZ	Absolute		x	x	3	4 <sup>1</sup>
9D	STA	Absolute Indexed, X	x	x	x	3	5 <sup>1</sup>
9E	STZ	Absolute Indexed, X		x	x	3	5 <sup>1</sup>
9F	STA	Absolute Long Indexed, X			x	4	5 <sup>1</sup>
A0	LDY	Immediate	x	x	x	2+	2 <sup>10</sup>
A1	LDA	DP Indexed Indirect, X	x	x	x	2	6 <sup>1,2</sup>
A2	LDX	Immediate	x	x	x	2+	2 <sup>10</sup>
A3	LDA	Stack Relative			x	2	4 <sup>1</sup>
A4	LDY	Direct Page	x	x	x	2	3 <sup>2,10</sup>
A5	LDA	Direct Page	x	x	x	2	3 <sup>1,2</sup>
A6	LDX	Direct Page	x	x	x	2	3 <sup>2,10</sup>
A7	LDA	DP Indirect Long			x	2	6 <sup>1,2</sup>
A8	TAY	Implied	x	x	x	1	2
A9	LDA	Immediate	x	x	x	2*	2 <sup>1</sup>
AA	TAX	Implied	x	x	x	1	2
AB	PLB	Stack (Pull)			x	1	4
AC	LDY	Absolute	x	x	x	3	4 <sup>10</sup>
AD	LDA	Absolute	x	x	x	3	4 <sup>1</sup>
AE	LDX	Absolute	x	x	x	3	4 <sup>10</sup>
AF	LDA	Absolute Long			x	4	5 <sup>1</sup>
B0	BCS	Program Counter Relative	x	x	x	2	2 <sup>7,8</sup>
B1	LDA	DP Indirect Indexed, Y	x	x	x	2	5 <sup>1,2,3</sup>
B2	LDA	DP Indirect		x	x	2	5 <sup>1,2</sup>
B3	LDA	SR Indirect Indexed, Y			x	2	7 <sup>1</sup>
B4	LDY	DP Indexed, X	x	x	x	2	4 <sup>2,10</sup>
B5	LDA	DP Indexed, X	x	x	x	2	4 <sup>1,2</sup>
B6	LDX	DP Indexed, Y	x	x	x	2	4 <sup>2,10</sup>
B7	LDA	DP Indirect Long Indexed, Y			x	2	6 <sup>1,2</sup>
B8	CLV	Implied	x	x	x	1	2
B9	LDA	Absolute Indexed, Y	x	x	x	3	4 <sup>1,3</sup>
BA	TSX	Implied	x	x	x	1	2
BB	TYX	Implied			x	1	2
BC	LDY	Absolute Indexed, X	x	x	x	3	4 <sup>3,10</sup>
BD	LDA	Absolute Indexed, X	x	x	x	3	4 <sup>1,3</sup>
BE	LDX	Absolute Indexed, Y	x	x	x	3	4 <sup>3,10</sup>
BF	LDA	Absolute Long Indexed, X			x	4	5 <sup>1</sup>
C0	CPY	Immediate	x	x	x	2+	2 <sup>10</sup>
C1	CMP	DP Indexed Indirect, X	x	x	x	2	6 <sup>1,2</sup>
C2	REP	Immediate			x	2	3
C3	CMP	Stack Relative			x	2	4 <sup>1</sup>

*Continued.*

## The Western Design Center

<i>Opcode</i>			<i>Available on:</i>			<i># of</i>	<i># of</i>
<i>Hex</i>	<i>Mnemonic</i>	<i>Addressing Mode</i>	<i>6502</i>	<i>65C02</i>	<i>65802/816</i>	<i>Bytes</i>	<i>Cycles</i>
C4	CPY	Direct Page	x	x	x	2	3 <sup>2,10</sup>
C5	CMP	Direct Page	x	x	x	2	3 <sup>1,2</sup>
C6	DEC	Direct Page	x	x	x	2	5 <sup>2,5</sup>
C7	CMP	DP Indirect Long			x	2	6 <sup>1,2</sup>
C8	INY	Implied	x	x	x	1	2
C9	CMP	Immediate	x	x	x	2*	2 <sup>1</sup>
CA	DEX	Implied	x	x	x	1	2
CB	WAI	Implied			x	1	3 <sup>15</sup>
CC	CPY	Absolute	x	x	x	3	4 <sup>10</sup>
CD	CMP	Absolute	x	x	x	3	4 <sup>1</sup>
CE	DEC	Absolute	x	x	x	3	6 <sup>5</sup>
CF	CMP	Absolute Long			x	4	5 <sup>1</sup>
D0	BNE	Program Counter Relative	x	x	x	2	2 <sup>7,8</sup>
D1	CMP	DP Indirect Indexed, Y	x	x	x	2	5 <sup>1,2,3</sup>
D2	CMP	DP Indirect		x	x	2	5 <sup>1,2</sup>
D3	CMP	SR Indirect Indexed, Y			x	2	7 <sup>1</sup>
D4	PEI	Stack (Direct Page Indirect)			x	2	6 <sup>2</sup>
D5	CMP	DP Indexed, X	x	x	x	2	4 <sup>1,2</sup>
D6	DEC	DP Indexed, X	x	x	x	2	6 <sup>2,5</sup>
D7	CMP	DP Indirect Long Indexed, Y			x	2	6 <sup>1,2</sup>
D8	CLD	Implied	x	x	x	1	2
D9	CMP	Absolute Indexed, Y	x	x	x	3	4 <sup>1,3</sup>
DA	PHX	Stack (Push)		x	x	1	3 <sup>10</sup>
DB	STP	Implied			x	1	3 <sup>14</sup>
DC	JMP	Absolute Indirect Long			x	3	6
DD	CMP	Absolute Indexed, X	x	x	x	3	41,3
DE	DEC	Absolute Indexed, X	x	x	x	3	7 <sup>5,6</sup>
DF	CMP	Absolute Long Indexed, X			x	4	5 <sup>1</sup>
E0	CPX	Immediate	x	x	x	2+	2 <sup>10</sup>
E1	SBC	DP Indexed Indirect, X	x	x	x	2	6 <sup>1,2,4</sup>
E2	CPX	Immediate			x	2	3 <sup>1</sup>
E3	SBC	Stack Relative			x	2	4 <sup>1,4</sup>
E4	INX	Direct Page	x	x	x	2	3 <sup>2,10</sup>
E5	SBC	Direct Page	x	x	x	2	3 <sup>1,2,4</sup>
E6	INC	Direct Page	x	x	x	2	5 <sup>2,5</sup>
E7	SBC	DP Indirect Long			x	2	6 <sup>1,2,4</sup>
E8	INX	Implied	x	x	x	1	2
E9	SBC	Immediate	x	x	x	2*	2 <sup>1,4</sup>
EA	NOP	Implied	x	x	x	1	2
EB	XBA	Implied			x	1	3
EC	CPX	Absolute	x	x	x	3	4 <sup>10</sup>
ED	SBC	Absolute	x	x	x	3	4 <sup>1,4</sup>
EE	INC	Absolute	x	x	x	3	6 <sup>5</sup>
EF	SBC	Absolute Long			x	4	5 <sup>1,4</sup>
F0	BEQ	Program Counter Relative	x	x	x	2	2 <sup>7,8</sup>
F1	SBC	DP Indirect Indexed, Y	x	x	x	2	5 <sup>1,2,3,4</sup>
F2	SBC	DP Indirect		x	x	2	5 <sup>1,2,4</sup>
F3	SBC	SR Indirect Indexed, Y			x	2	7 <sup>1,4</sup>
F4	PEA	Stack (absolute)			x	3	5
F5	SBC	DP Indexed, X	x	x	x	2	4 <sup>1,2,4</sup>

*Continued.*

## The Western Design Center

<i>Opcode</i>			<i>Available on:</i>			<i># of</i>	<i># of</i>
<i>Hex</i>	<i>Mnemonic</i>	<i>Addressing Mode</i>	<i>6502</i>	<i>65C02</i>	<i>65802/816</i>	<i>Bytes</i>	<i>Cycles</i>
F6	INC	DP Indexed, X	x	x	x	2	6 <sup>2,5</sup>
F7	SBC	DP Indirect Long Indexed, Y			x	2	6 <sup>1,2,4</sup>
F8	SED	Implied	x	x	x	1	2
F9	SBC	Absolute Indexed, Y	x	x	x	3	4 <sup>1,3,4</sup>
FA	PLX	Stack /Pull		x	x	1	4 <sup>10</sup>
FB	XCE	Implied			x	1	2
FC	JSR	Absolute Indexed Indirect			x	3	8
FD	SBC	Absolute Indexed, X	x	x	x	3	4 <sup>1,3,4</sup>
FE	INC	Absolute Indexed, X	x	x	x	3	7 <sup>5,6</sup>
FF	SBC	Absolute Long Indexed, X			x	4	5 <sup>1,4</sup>

+ Add 1 byte if m=0 (16-bit memory/accumulator)

++ opcode is 1 byte, but program counter value pushed onto stack is incremented by 2 allowing for optional signature byte

+ Add 1 byte if x=0 (16-bit index register)

1. Add 1 cycle if m=0 (16-bit memory/accumulator)

2. Add 1 cycle if low byte of Direct Page register is other than zero (DL<>0)

3. Add 1 cycle if adding index crosses a page boundary

4. Add 1 cycle if 65C02 and d=1 (decimal mode, 65C02)

5. Add 2 cycles if m=0 (16-bit memory/accumulator)

6. Subtract 1 cycle if 65C02 and no page boundary crossed

7. Add 1 cycle if branch is taken

8. Add 1 more cycle if branch taken crosses page boundary on 6502, 65C02, or 65816/65802's 6502 emulation mode (e=1)

9. Add 1 cycle for 65802/65816 native mode (e=0)

10. Add 1 cycle if x=0 (16-bit index register)

11. Add 1 cycle if 65C02

12. 6502: If low byte of operand is \$FF (i.e., operand is \$xxFF): yields incorrect result

13. 7 cycles per byte moved

14. Uses 3 cycles to shut the processor down; additional cycles are required by reset to restart it

15. Uses 3 cycles to shut the processor down; additional cycles are required by interrupt to restart it

16. Bytes and cycle counts subject to change in future processors which expand WDM into 2-byte opcode portions of instructions of varying lengths.

# The Western Design Center

Mnemonic	Operation	#	a	d	s	A	-	(d),y	(d),y	(d,x)	d,x	d,y	d,x	Processor Status Code										
														7	6	5	4	3	2	1	0			
														N	V	M	X	D	I	Z	C			
		1	2	3	4	5	6	7	8	9	10	11	12	N	V	I	B	D	I	Z	C			
ADC	A + M + C → A	69	6D	6F	65			71	77	61	75		7D	N	V	.	.	.	.	.	Z	C		
AND	A ∧ M → A	29	2D	2F	25			31	37	21	35		3D	N	.	.	.	.	.	.	Z	.		
ASL	C - [15/7 0] ← 0		0E		06	0A					16		1E	N	.	.	.	.	.	.	Z	C		
BCC	Branch if C=0														.	.	.	.	.	.	.	.		
BCS	Branch if C=1														.	.	.	.	.	.	.	.		
BEQ	Branch if Z=1														.	.	.	.	.	.	.	.		
BIT	A ∧ M (Note 1)	89	2C		24						34		3C	M7	M6	.	.	.	.	.	Z	.		
BMI	Branch if N=1														.	.	.	.	.	.	.	.		
BNE	Branch if Z=0														.	.	.	.	.	.	.	.		
BPL	Branch if N=0														.	.	.	.	.	.	.	.		
BRA	Branch Always														.	.	.	.	.	.	.	.		
BRK	Break (Note 2)														.	.	.	.	.	.	.	.		
BRL	Branch Long Always														.	.	.	.	.	.	.	.		
BVC	Branch if V=0														.	.	.	.	.	.	.	.		
BVS	Branch if V=1														.	.	.	.	.	.	.	.		
CLC	0 ← C						18								.	.	.	.	.	.	.	0		
CLD	0 ← D						D8								.	.	.	.	.	.	.	0		
CLI	0 ← I						58								.	.	.	.	.	.	.	0		
CLV	0 ← V						B8								0	.	.	.	.	.	.	.		
CMP	A - M	C9	CD	CF	C5			D1	D7	C1	D5		DD	N	.	.	.	.	.	.	.	Z	C	
COP	Co-Processor														.	.	.	.	.	.	.	0	I	.
CPX	X - M	E0	EC		E4										N	.	.	.	.	.	.	Z	C	
CPY	Y - M	C0	CC		C4										N	.	.	.	.	.	.	Z	C	
DEC	Decrement		CE		C6	3A					D6		DE	N	.	.	.	.	.	.	.	Z	.	
DEX	X - 1 → X						CA								N	.	.	.	.	.	.	Z	.	
DEY	Y - 1 → Y						88								N	.	.	.	.	.	.	Z	.	
EOR	A ⊕ M → A	49	4D	4F	45	1A		51	57	41	55		5D	N	.	.	.	.	.	.	.	Z	.	
INC	Increments		EE		E6						F6		FE	N	.	.	.	.	.	.	.	Z	.	
INX	X + 1 → X						E8								N	.	.	.	.	.	.	Z	.	
INY	Y + 1 → Y						C8								N	.	.	.	.	.	.	Z	.	
JML	Jump Long to new Location														.	.	.	.	.	.	.	.	.	
JMP	Jump to New Location		4C	5C											.	.	.	.	.	.	.	.	.	
JSL	Jump Long to Subroutine			22											.	.	.	.	.	.	.	.	.	
JSR	Jump to Subroutine		20												.	.	.	.	.	.	.	.	.	
LDA	M → A	A9	AD	AF	A5			B1	B7	A1	B5		BD	N	.	.	.	.	.	.	.	Z	.	
LDX	M → X	A2	AE		A6							B6		N	.	.	.	.	.	.	.	Z	.	
LDY	M → Y	A0	AC		A4							B4		N	.	.	.	.	.	.	.	Z	.	
LSR	0 → [15/7 0] ← C		4E		46	4A					56		5E	0	.	.	.	.	.	.	.	Z	C	
MVM	M - M Negative														.	.	.	.	.	.	.	.	.	
MVP	M - M Positive														.	.	.	.	.	.	.	.	.	
NOP	No Operation						EA								.	.	.	.	.	.	.	.	.	
ORA	A ∨ M → A	09	0D	0F	05			11	17	01	15		1D	N	.	.	.	.	.	.	.	Z	.	
PEA	Mpc+1, Mpc+2 - Ms-1, Ms S-2 - S														.	.	.	.	.	.	.	.	.	
PEI	M(d), M(d+1) - Ms-1, Ms S-2 - S														.	.	.	.	.	.	.	.	.	
PER	Mpc+rl, Mpc+rl+1 - Ms-1 MsS-2 - S														.	.	.	.	.	.	.	.	.	

The Western Design Center

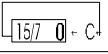
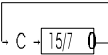
Mnemonic	Operation	#	a	a1	a	A	-	(a)1y	(a)1y	(a)1x	a1x	a1y	a1x	Processor Status Code											
														7	6	5	4	3	2	1	0				
														N	V	M	X	D	I	Z	C				
		1	2	3	4	5	6	7	8	9	10	11	12	N	V	I	B	D	I	Z	C				
PHA	A-Ms, S-1-S													.	.	.	.	.	.	.	.	.	.	.	.
PHB	DBR-Ms, S-1-S													.	.	.	.	.	.	.	.	.	.	.	.
PHD	D-Ms, Ms-1, S-2-S													.	.	.	.	.	.	.	.	.	.	.	.
PHK	FBR-Ms, S-1-S													.	.	.	.	.	.	.	.	.	.	.	.
PHP	P-Ms, S-1-S													.	.	.	.	.	.	.	.	.	.	.	.
PHX	X-Ms, S-1-S													.	.	.	.	.	.	.	.	.	.	.	.
PHY	Y-Ms, S-1-S													.	.	.	.	.	.	.	.	.	.	.	.
PLA	S + 1-S, Ms-A													N	.	.	.	.	.	.	.	.	Z	.	.
PLB	S + 1-S, Ms-DBR													N	.	.	.	.	.	.	.	.	Z	.	.
PDL	S + 2-S, Ms-1, Ms-D													N	.	.	.	.	.	.	.	.	Z	.	.
PLP	S - 1-S, Ms-P													N	V	M	X	D	I	Z	C	.	.	.	.
PLX	S - 1-S, Ms-X													N	.	.	.	.	.	.	.	.	Z	.	.
PLY	S - 1-S, Ms-Y													N	.	.	.	.	.	.	.	.	Z	.	.
REP	M/P-P	C2												N	V	M	X	D	I	Z	C	.	.	.	.
ROL	 - C		2E		26	2A							36	3E	N	.	.	.	.	.	.	.	Z	C	.
ROR	 - C														N	.	.	.	.	.	.	.	Z	C	.
RTI	Return from Interrupt		6E		66	6A							76	7E	N	V	M	X	D	I	Z	C	.	.	
RTL	Return from Subroutine Long														.	.	.	.	.	.	.	.	.	.	.
RTS	Return Subroutine														.	.	.	.	.	.	.	.	.	.	.
SBC	A-M-C-A	E9	ED	EF	E5			F1	F6	E1	F5		FD	N	V	.	.	.	.	.	.	.	Z	C	.
SEC	16C							38						.	.	.	.	.	.	.	.	.	.	.	.
SED	16D							FB						.	.	.	.	.	.	.	.	.	.	.	.
SEI	16I							78						.	.	.	.	.	.	.	.	.	.	.	.
SEP	M/P-P	E2												N	V	M	X	D	I	Z	C	.	.	.	.
STA	A-M		8D	8F	85			91	97	81	95		9D	.	.	.	.	.	.	.	.	.	.	.	.
STP	STOP(1-Ph2)						DB							.	.	.	.	.	.	.	.	.	.	.	.
STX	X-M		8E		86								96	.	.	.	.	.	.	.	.	.	.	.	.
STY	Y-M		8C		84							94		.	.	.	.	.	.	.	.	.	.	.	.
STZ	00-M		9C		64							74	9E	.	.	.	.	.	.	.	.	.	.	.	.
TAX	A-X													N	.	.	.	.	.	.	.	.	Z	.	.
TAY	A-Y					A8								N	.	.	.	.	.	.	.	.	Z	.	.
TCD	C-D					5B								N	.	.	.	.	.	.	.	.	Z	.	.
TCS	C-S					1B								.	.	.	.	.	.	.	.	.	.	.	.
TDC	D-C					7B								N	.	.	.	.	.	.	.	.	Z	.	.
TRB	A/M-M		1C		14									.	.	.	.	.	.	.	.	.	Z	.	.
TSB	A/M-M		0C		04									.	.	.	.	.	.	.	.	.	Z	.	.
TSC	S-C							3B						N	.	.	.	.	.	.	.	.	Z	.	.
TSX	S-X							BA						N	.	.	.	.	.	.	.	.	Z	.	.
TSA	X-A							SA						N	.	.	.	.	.	.	.	.	Z	.	.
TXS	X-S							9A						.	.	.	.	.	.	.	.	.	.	.	.
TXY	X-Y							9B						N	.	.	.	.	.	.	.	.	Z	.	.
TYA	Y-A							9B						N	.	.	.	.	.	.	.	.	Z	.	.
TYX	Y-X							BB						N	.	.	.	.	.	.	.	.	Z	.	.
WAI	0-RDY							CB						.	.	.	.	.	.	.	.	.	.	.	.
WDM	No Operation (Reserved)							42						.	.	.	.	.	.	.	.	.	.	.	.
XBA	B-A							EB						N	.	.	.	.	.	.	.	.	Z	.	.
XCE	C-E							FB						.	.	.	.	.	.	.	.	.	.	.	E

# The Western Design Center

Mnemonic	Operation	a1,x	a,y	r1	r1	(a)	(d)	(b)	(a,x)	s	d,s	(d,s)y	a,x	Processor Status Code								
														7	6	5	4	3	2	1	0	
														N	V	M	X	D	I	Z	C	
ADC	A + M + C - A	7F	79				72	67			63	73		N	V	.	.	.	.	Z	C	
AND	A ^ M - A	3F	39				32	27			23	33		N	.	.	.	.	.	Z	.	
ASL	C - [15/7 0] - 0													N	V	.	.	.	.	Z	C	
BCC	Branch if C=0			90										.	.	.	.	.	.	.	.	
BCS	Branch if C=1			80										.	.	.	.	.	.	.	.	
BEQ	Branch if Z=1			F0										.	.	.	.	.	.	.	.	
BIT	A ^ M (Note 1)													M7	M6	.	.	.	.	Z	.	
BMI	Branch if N=1			30										.	.	.	.	.	.	.	.	
BNE	Branch if Z=0			D0										.	.	.	.	.	.	.	.	
BPL	Branch if N=0			10										.	.	.	.	.	.	.	.	
BRA	Branch Always			80										.	.	.	.	.	.	.	.	
BRK	Break (Note 2)													.	.	.	.	.	.	.	.	
BRL	Branch Long Always				82									.	.	.	.	.	.	.	.	
BVC	Branch if V=0			50										.	.	.	.	.	.	.	.	
BVS	Branch if V=1			70										.	.	.	.	.	.	.	.	
CLC	0-C													.	.	.	.	.	.	.	0	
CLD	0-D													.	.	.	.	.	.	.	.	
CLI	0-1													.	.	.	.	.	.	.	.	
CLV	0-V													.	.	.	.	.	.	.	.	
CMP	A-M	DF	D9				D2	C7			C3	D3		N	.	.	.	.	.	.	Z	C
COP	Co-Processor										02			.	.	.	.	.	.	.	.	
CPX	X-M													.	.	.	.	.	.	.	.	
CPY	Y-M													N	.	.	.	.	.	.	Z	C
DEC	Decrement													N	.	.	.	.	.	.	Z	.
DEX	X-1-X													N	.	.	.	.	.	.	Z	.
DEY	Y-1-Y													N	.	.	.	.	.	.	Z	.
EOR	A ^ M - A	5F	59				52	47			43	53		N	.	.	.	.	.	.	Z	.
INC	Increments													N	.	.	.	.	.	.	Z	.
INX	X+1-X													N	.	.	.	.	.	.	Z	.
INY	Y+1-Y													N	.	.	.	.	.	.	Z	.
JML	Jump Long to new Location					DC								.	.	.	.	.	.	.	.	.
JMP	Jump to New Location					6C				7C				.	.	.	.	.	.	.	.	.
JSL	Jump Long to Subroutine													.	.	.	.	.	.	.	.	.
JSR	Jump to Subroutine									FC				.	.	.	.	.	.	.	.	.
LDA	M-A	BF	B9				B2	A7			A3	B3		N	.	.	.	.	.	.	Z	.
LDX	M-X		BE											N	.	.	.	.	.	.	Z	.
LDY	M-Y													N	.	.	.	.	.	.	Z	.
LSR	0 - [15/7 0] - C													0	.	.	.	.	.	.	Z	C
MVM	M-M Negative												54	.	.	.	.	.	.	.	.	.
MVP	M-M Positive												44	.	.	.	.	.	.	.	.	.
NOP	No Operation													.	.	.	.	.	.	.	.	.
ORA	A ^ M - A	1F	19				12	07			03			N	.	.	.	.	.	.	Z	.
PEA	Mpc+1, Mpc+2 - Ms-1, Ms S-2 - S													.	.	.	.	.	.	.	.	.
PEI	M(d), M(d+1) - Ms-1, Ms S-2 - S													.	.	.	.	.	.	.	.	.
PER	Mpc+r1, Mpc+r1+1 - Ms-1 Ms S-2 - S													.	.	.	.	.	.	.	.	.



# The Western Design Center

Mnemonic	Operation	a,x	a,y	r1	r1	(a)	(d)	(d)	(a,x)	s	d,s	(d,s),y	a,x	Processor Status Code							
														7	6	5	4	3	2	1	0
														N	V	M	X	D	I	Z	C
	^ AND v OR v Exclusive OR	13	14	15	16	17	18	19	20	21	22	23	24	N	V	I	B	D	I	Z	C
PHA	A-Ms, S-1-S									48				.	.	.	.	.	.	.	.
PHB	DBR-Ms, S-1-S									8B				.	.	.	.	.	.	.	.
PHD	D-Ms, Ms-1, S-2-S									0B				.	.	.	.	.	.	.	.
PHK	PBR-Ms, S-1-S									4B				.	.	.	.	.	.	.	.
PHP	P-Ms, S-1-S									08				.	.	.	.	.	.	.	.
PHX	X-Ms, S-1-S									DA				.	.	.	.	.	.	.	.
PHY	Y-Ms, S-1-S									5A				.	.	.	.	.	.	.	.
PLA	S + 1-S, Ms-A									68				N	.	.	.	.	.	Z	.
PLB	S + 1-S, Ms-DBR									AB				N	.	.	.	.	.	Z	.
PLDL	S + 2-S, Ms-1, Ms-D									2B				N	.	.	.	.	.	Z	.
PLP	S + 1-S, MS-P									28				N	V	M	X	D	I	Z	C
PLX	S + 1-S, MS-X									FA				N	.	.	.	.	.	Z	.
PLY	S + 1-S, MS-Y									7A				N	.	.	.	.	.	Z	.
REP	M-/P-P													N	V	M	X	D	I	Z	C
ROL														N	.	.	.	.	.	Z	C
ROR														N	.	.	.	.	.	Z	C
RTI	Return from Interrupt									40				N	V	M	X	D	I	Z	C
RTL	Return from Subroutine Long									6B				.	.	.	.	.	.	.	.
RTS	Return Subroutine									60				.	.	.	.	.	.	.	.
SBC	A-M-C-A	FF	F9				F2	E7			E3	F3		N	V	.	.	.	.	Z	C
SEC	1-C													.	.	.	.	.	.	.	1
SED	1-D													.	.	.	.	1	.	.	.
SEI	1-I													.	.	.	.	1	.	.	.
SEP	M-P-P													N	V	M	X	D	I	Z	C
STA	A-M	9F	99				92	87						.	.	.	.	.	.	.	.
STP	STOP(1-PH2)													.	.	.	.	.	.	.	.
STX	X-M													.	.	.	.	.	.	.	.
STY	Y-M													.	.	.	.	.	.	.	.
STZ	00-M													.	.	.	.	.	.	.	.
TAX	A-X													N	.	.	.	.	.	Z	.
TAY	A-Y													N	.	.	.	.	.	Z	.
TCD	C-D													N	.	.	.	.	.	Z	.
TCS	C-S													.	.	.	.	.	.	.	.
TDC	D-C													N	.	.	.	.	.	Z	.
TRB	A-/M-M													N	.	.	.	.	.	Z	.
TSB	A/M-M													.	.	.	.	.	.	Z	.
TSC	S-C													N	.	.	.	.	.	Z	.
TSX	S-X													N	.	.	.	.	.	Z	.
TSA	X-A													N	.	.	.	.	.	Z	.
TXS	X-S													.	.	.	.	.	.	.	.
TXY	X-Y													N	.	.	.	.	.	Z	.
TYA	Y-A													N	.	.	.	.	.	Z	.
TYX	Y-X													N	.	.	.	.	.	Z	.
WAI	0-RDY													.	.	.	.	.	.	.	.
WDM	No Operation (Reserved)													.	.	.	.	.	.	.	.
XBA	B-A													N	.	.	.	.	.	Z	.
XCE	C-E													.	.	.	.	.	.	.	E

## The Western Design Center

### Processor

- Opcode or instruction first introduced on the 65C02
- ★ Opcode or instruction first introduced on the 65816/65802  
(not marked: first introduced on the NMOS 6502)

### Addressing mode box:

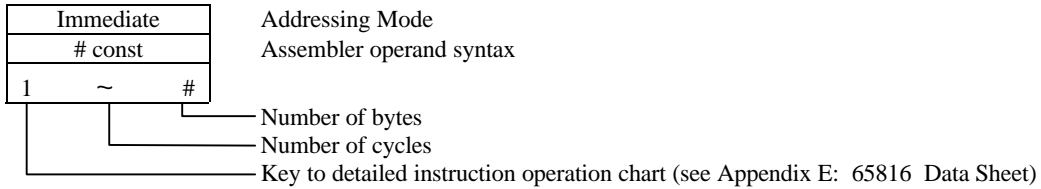

### Operation column:

- A Accumulator
- X Index register X
- Y Index register Y
- M Contents of memory location specified by effective address
- M(d) Contents of direct page memory location pointed to by operand
- M(s) Contents of memory location pointed to by stack pointer
- M(pc) Current opcode pointed to by the program counter
- PC Memory location of current opcode pointed to by the program counter
- r1 Two-byte operand of relative long addressing mode instruction
- + Add
- Subtract
- ^ And
- ∨ Or
- ⊕ Exclusive Or
- Logical complement of a value or status bit ( $\overline{A}$  indicates the complement of the value in the accumulator)
- ∅2 Phase 2 clock (hardware signal)
- RDY Ready (hardware signal)

## The Western Design Center

### *Bytes, cycles, and status codes:*

- \* Add 1 byte if M = 0 (16-bit memory/accumulator)
- \*\* opcode is one byte, but program counter value pushed onto stack is incremented by 2 allowing for optional signature byte
- + Add 1 byte if x = 0 (16-bit index registers)
- n number of bytes moved
- 1 Add 1 cycle if m = 0 (16-bit memory/accumulator)
- 2 Add 1 cycle if low byte of Direct Page register is other than zero (DL < > 0)
- 3 Add 1 cycle if adding index crosses a page boundary
- 4 Add 1 cycle if 65C02 and d = 1 (decimal mode, 65C02)
- 5 Add 2 cycles if m = 0 (16-bit memory/accumulator)
- 6 Subtract 1 cycle if 65C02 and no page boundary crossed
- 7 Add 1 cycle if branch is taken
- 8 Add 1 more cycle if branch taken crosses page boundary on 6502, 655C02, or 65816/65802's 6502 emulation mode (e = 1)
- 9 Add 1 cycle for 65802/65816 native mode (e = 0)
- 10 Add 1 cycle if x = 0 (16-bit index registers)
- 11 Add 1 cycle if 65C02
- 12 6502: If low byte of *addr* is \$FF (i.e., *addr* is \$xxFF): yields incorrect result
- 13 7 cycles per byte moved
- 14 Uses 3 cycles to shut the processor down; additional cycles are required by reset to restart it
- 15 Uses 3 cycles to shut the processor down; additional cycles are required by interrupt to restart it
- 16 Bytes and cycle counts subject to change in future processors which expand WDM into 2-byte opcode portions of instructions of varying lengths
- 17 BIT: immediate n and v flags not affected; if m = 0, m(15) → n and M(14) → V; if m = 1, m(7) → n and M(6) → v
- 18 BRK: if b = 1 in pushed status register (6502, 65C02 and emulation mode e = 1), then interrupt was caused by software BRK:  
if 6502, d is unaffected by BRK; if 65C02 or 65816/65802, d is 0 after BRK

MSD		LSD														MSD	
0	1	2	3	4	5	6	7	8	9	A	B	C	D	E	F	0	
BRK	ORA(dx)	COP	ORA(ds)	TSB	ORA(d)	ASL(d)	ORA(dj)	PIP	ORA(#)	ASLA	PHD	TSB	ORA(a)	ASLA	ORA(d)		
BRL	ORA(dly)	ORA(d)	ORA(dsly)	TRB	ORA(dx)	ASL(dx)	ORA(dly)	CLC	ORA(ay)	INCA	TCS	TRB	ORA(ax)	ASL(ax)	ORA(dx)		
JRQ	AND(ay)	LSL	AND(ds)	BIT	AND(d)	ROL(d)	AND(dj)	RLP	AND(#)	ROLA	RLD	BIT	AND(a)	ROLA	AND(d)		
BML	AND(dly)	AND(d)	AND(dsly)	BIT(dx)	AND(dx)	ROL(dx)	AND(dly)	SEC	AND(ay)	DECA	TSC	BIT	AND(ax)	ROL(ax)	AND(dx)		
RTS	EOR(dx)	WDM	EOR(ds)	MPXVC	EOR(d)	LSR(d)	EOR(dj)	PHS	EOR(#)	LSRA	PHS	JMP	EOR(a)	LSRA	EOR(d)		
BVC	EOR(dly)	EOR(d)	EOR(dsly)	MNVC	EOR(dx)	LSR(dx)	EOR(dly)	CH	EOR(ay)	PHS	TCD	JMP(d)	EOR(ax)	LSR(ax)	EOR(dx)		
RTS	ADC(dx)	PER	ADC(ds)	SIZ	ADC(d)	ROR(d)	ADC(dj)	PLA	ADC(#)	RORA	RTS	JMP(i)	ADC(a)	ROR(a)	ADC(d)		
BVS	ADC(dly)	ADC(d)	ADC(dsly)	SIZ(dx)	ADC(dx)	ROR(dx)	ADC(dly)	SEL	ADC(ay)	PLS	TDC	JMP(ax)	ADC(ax)	ROR(ax)	ADC(dx)		
BRA	STA(dx)	BRL	STA(ds)	STY	STA(d)	STX	STA(dj)	DEF	BIT(#)	TXAI	PHB	STY	STA(a)	STX	STA(d)		
BCC	STA(dly)	STA(d)	STA(dsly)	STY(dx)	STA(dx)	STX	STA(dly)	TXI	STA(ay)	TXS	TXY	STZ	STA(ax)	STZ	STA(dx)		
LDY	LDA(dx)	LDX	LDA(ds)	LDY	LDA(d)	LDX	LDA(dj)	TAY	LDA(#)	TAX	PLB	LDY	LDA(a)	LDX	LDA(d)		
BCL	LDA(dly)	LDA(d)	LDA(dsly)	LDY(dx)	LDA(dx)	LDX	LDA(dly)	CLV	LDA(ay)	TSX	TXI	LDY	LDA(ax)	LDX	LDA(dx)		
CPY	CMP(dx)	REP	CMP(ds)	CPY	CMP(d)	DEC	CMP(dj)	INV	CMP(#)	DEX	WAI	CPY	CMP(a)	DEC	CMP(d)		
BNE	CMP(dly)	CMP(d)	CMP(dsly)	PEL	CMP(dx)	DEC	CMP(dly)	GLD	CMP(ay)	PHS	STP	JML	CMP(ax)	DEC	CMP(dx)		
CPX	SBC(dx)	SEP	SBC(ds)	CPX	SBC(d)	INC	SBC(dj)	INX	SBC(#)	NOPI	XBA	CPX	SBC(a)	INC	SBC(d)		
BEQ	SBC(dly)	SBC(d)	SBC(dsly)	PEA	SBC(dx)	INC	SBC(dly)	SED	SBC(ay)	PLS	XCE	JSR	SBC(ax)	INC	SBC(dx)		
0	1	2	3	4	5	6	7	8	9	A	B	C	D	E	F		

**Op Code Matrix Legend**

INSTRUCTION MNEMONIC	★ = New W65C816/802 Opcodes ● = New W65C02 Opcodes Blank = NMOS 6502 Opcodes	ADDRESSING MODE
BASE NO. BYTES		BASE NO CYCLES

symbol	addressing mode	symbol	addressing mode
#	immediate	[d]	direct indirect long
A	accumulator	[d],y	direct indirect long indexed
r	program counter relative	a	absolute
rl	program counter relative long	a,x	absolute indexed (with x)
i	implied	a,y	absolute indexed (with y)
s	stack	al	absolute long
d	direct	al,x	absolute long indexed
d,x	direct indexed (with x)	d,s	stack relative
d,y	direct indexed (with y)	(d,s),y	stack relative indirect indexed
(d)	direct indirect	(a)	absolute indirect
(d,x)	direct indexed indirect	(a,x)	absolute indexed indirect
(d),y	direct indirect indexed	xyz	block move

## The Western Design Center

accumulators, 19

**address**, 12

**AND**, 15

arithmetic., 19

    multiple-precision, 19

**ASCII**, 11, 14

assembler, 19

assembler **directives**, 21

**Assembly Language**, 21

**back space**, 14

**BASIC**, 19

Binary arithmetic, 19

**binary digit**, 11

**binary-coded decimal**, 11, 18

**bit**, 11

**bitwise**, 15

**branch**, 23

    conditional, 23

**macro assemblers**, 21

number systems, 11

## *Table of Contents*

### *Appendices*

<b>A. 65x Signal Description .....</b>	<b>4</b>
6502 Signals .....	6
Address Bus .....	6
Clock Signals .....	6
Data Bus .....	6
Data Bus Enable .....	6
Read/Write .....	6
Ready .....	6
Interrupt Request .....	6
Sync .....	7
Reset .....	7
65C02 Signals .....	7
Memory Lock .....	7
Notes .....	7
65802 Signals .....	7
65816 Signals .....	7
Bank Address .....	8
Vector Pull .....	8
Abort .....	8
Valid Program Address and Valid Data Address .....	8
Memory and Index .....	8
Emulation .....	9
Bus Enable .....	9
<b>B. 65x Series Support Chips .....</b>	<b>10</b>
The 6551 Serial Chip .....	10
STATUS .....	11
COMMAND REGISTER .....	12
BIT .....	12
OPERATION .....	12
The 6521 Parallel Chip .....	15
<b>C. The Rockwell 65C02 .....</b>	<b>18</b>
BBR .....	19
Branch on Bit Reset .....	19
BBS .....	20
Branch on Bit Set .....	20
RMB .....	21
Reset Memory Bit .....	21
SMB .....	22
Set Memory Bit .....	22
<b>D. Instruction Groups .....</b>	<b>23</b>
Group I Instructions .....	23
Group II Instructions .....	24
Loading the Index Registers .....	25
Index Register Compares .....	25
Test-and-Change-Bits Instructions .....	25
<b>E. The ASCII Character Set .....</b>	<b>26</b>

### *Table of Figures*

Figure A-1 65x Pinouts .....	5
Figure B-1. 6551 Status Register .....	11
Figure B-2. 6551 Control Register .....	12
Figure B-3Control Register .....	13

## *Table of Tables*

Table D-1 Group I Instructions Opcode Patterns .....	23
Table D-2 Address Mode Patterns for Group I Instructions .....	23
Table D-3 65802/65816 Group I Addressing Mode Patterns.....	23
Table D-4 Group II Opcode Patterns.....	24
Table D-5 Address Mode Patterns for Group II Instruction .....	24
Table D-6 Address Mode Patterns for Load Index Register Instruction.....	25
Table D-7 Address Mode Patterns for Compare Index Register Instructions .....	25



# Appendices

## A. 65x Signal Description

The four standard 65x parts considered in this book – the 6502, 65C02, 65802, and 65816 – are each housed in a 40-pin dual in-line package. There are also a number of special versions of the basic parts, versions with external clocks, fewer address pins, one-chip computers with on-board RAM and ROM, and with quadrature clocks. These are not considered here; refer to the appropriate manufacturer's literature for details about these special chips.

This appendix describes the pin signals found on the four standard parts – the pins that connect the processor to the external system. Many of them are common to all processors, some are unique to each.

The descriptions are meant to satisfy the programmer with a general interest in the system implementation; the engineer implementing a 65x system should consult the manufacturer's data sheets for more detailed information.

To begin with, refer to Figure A.1, which illustrates the pin configurations of the four different processors.

# Western Design Center

VSS	1		40	RESB	VSS	1		40	RESB
RDY	2		39	PHI2O	RDY	2		39	PHI2O
PHI1O	3		38	SOB	PHI1O	3		38	SOB
IRQB	4		37	PHI2I	IRQB	4		37	PHI2I
NC	5		36	NC	MLB	5		36	NC
NMIB	6		35	NC	NMIB	6		35	NC
SYNC	7		34	RWB	SYNC	7		34	RWB
VDD	8		33	D0	VDD	8		33	D0
A0	9		32	D1	A0	9		32	D1
A1	10		31	D2	A1	10		31	D2
A2	11		30	D3	A2	11		30	D3
A3	12	6502	29	D4	A3	12	65C02	29	D4
A4	13		28	D5	A4	13		28	D5
A5	14		27	D6	A5	14		27	D6
A6	15		26	D7	A6	15		26	D7
A7	16		25	A15	A7	16		25	A15
A8	17		24	A14	A8	17		24	A14
A9	18		23	A13	A9	18		23	A13
A10	19		22	A12	A10	19		22	A12
A11	20		21	VSS	A11	20		21	VSS

VPB	1		40	RESB	VSS	1		40	RESB
RDY	2		39	VDA	RDY	2		39	PHI2O
ABORTB	3		38	M/X	PHI1O	3		38	SOB
IRQB	4		37	PHI2I	IRQB	4		37	PHI2I
MLB	5		36	BE	NC	5		36	NC
NMIB	6		35	E	NMIB	6		35	NC
VPA	7		34	RWB	SYNC	7		34	RWB
VDD	8	W65C816	33	D0/BA0	VDD	8	W65C802	33	D0
A0	9		32	D1/BA1	A0	9		32	D1
A1	10		31	D2/BA2	A1	10		31	D2
A2	11		30	D3/BA3	A2	11		30	D3
A3	12		29	D4/BA4	A3	12		29	D4
A4	13		28	D5/BA5	A4	13		28	D5
A5	14		27	D6/BA6	A5	14		27	D6
A6	15		26	D7/BA7	A6	15		26	D7
A7	16		25	A15	A7	16		25	A15
A8	17		24	A14	A8	17		24	A14
A9	18		23	A13	A9	18		23	A13
A10	19		22	A12	A10	19		22	A12
A11	20		21	VSS	A11	20		21	VSS

Figure A-1 65x Pinouts

## Western Design Center

### 6502 Signals

The 6502 defines the basic set of signals.

#### Address Bus

Pins A0 – A15 are the address lines. Every time an address is generated – opcodes fetch, operand read, intermediate address, or effective address of a read or write operation – the binary value of the address appears on these pins, **A0** representing the low-order bit of the address, and **A15** representing the high-order bit. These outputs are TTL compatible.

#### Clock Signals

All of the 65x series processors operate on a two-phase external cycle; a 65, processor's frequency, expressed in Megahertz, or millions of cycles per second, is also its memory-access cycle time. The 6502 has an internal clock generator based on the **phase zero** input signal, a time base typically provided by a crystal oscillator. The two output signals, **phase one** and **phase two**, are derived from this signal. Phase one goes high when phase zero is low; phase two goes low on the rising edge of phase one.

#### Data Bus

Pins **D0-D7** are the **data lines**; these eight pins form a bi-directional data bus to read and write data between the processor and memory and the peripheral devices. Like the address lines, the outputs can drive one standard TTL load.

#### Data Bus Enable

This controls the three-state output buffers of the processors; it normally is enabled by the phase two output, effectively disabling the output buffers during phase one; this frees the bus for access by other devices during phase one. By pulling **DBE** low, the buffers may be disabled externally.

#### Read/Write

**R/W'** is high when data is being read from memory or peripherals into the processor, low when the processor is writing data. When in the low state, data and address lines have valid data and addresses.

#### Ready

The **RDY** signal enables the processor to be single-stepped on all cycles except write cycles. When enabled during phase one, the processor is halted and the address lines maintain the current address; this lets the processor interface with lower-speed read-only memory devices, and can also be used in direct memory access implementations.

#### Interrupt Request

The **IRQ'** signal requests that an interrupt-service cycle be initiated. This signal is connected to peripheral devices that are designed to be interrupt-driven. This is the maskable interrupt signal, so the interrupt disable flag in the status register must be zero for the interrupt to be effective. The **RDY** signal must be high for an interrupt to be recognized. **IRQ'** is sampled during phase 2.

#### Non-maskable Interrupt

**NMI'** is basically identical to **IRQ'**, except that it causes an unconditional interrupt when it is asserted, and control vectors through the **NMI'** vector rather than **IRQ'**.

## Western Design Center

### Set Overflow

When this line goes low on the trailing edge of phase one, the overflow flag in the processor status register is set.

### Sync

This line goes high during phase one of those cycles that are opcode fetches. When used with the **RDY** signal, this allows hardware implementation of a single-step debugging capability.

### Reset

**RESET'** reinitializes the processor, either at power-up or to restart the system from a known state. **RESET'** must be held low for at least two cycles after a power down. When it is asserted, an interrupt-like service routine begins (although the status and program counter are not stacked), with the result that control is transferred through the **RESET'** vector.

## 65C02 Signals

The 65C02 pinout is identical to the 6502, with the exception of memory lock and notes described below.

### Memory Lock

The **ML'** output signal assures the integrity of read-modify-write instructions by signaling other devices, for example, other processors in a multiprocessor environment, that the bus may not be claimed until completion of the read-modify-write operation. This signal goes low during the execution of the memory-referencing (non-register operand) **ASL**, **DEC**, **INC**, **LSR**, **ROL**, **ROR**, **TRB**, and **TSB** instructions.

### Notes

The 65C02, unlike the 6502, responds to **RDY** during a write cycle as well as a read, halting the processor.

Response of the 65C02 to a reset is different from the 6502 in that the 65C02's program counter and status register are written to the stack. Additionally, the 65C02 decimal flag is cleared after reset or interrupt; its value is indeterminate after reset and not modified after interrupt on the 6502.

When an interrupt occurs immediately after the fetch of a **BRK** instruction on the 6502, the **BRK** is ignored; on the 65C02, the **BRK** is executed, then the interrupt is executed.

Finally, the 65C02 R/W' line is high during the modify (internal operation) cycle of the read-modify-write operations; on the 6502, it is low.

## 65802 Signals

The 65802 signals are by definition 6502 pin-compatible. The 65C02 **ML'** (memory lock) signal is not on the standard pin-out, although it is available as a special-order mask option. Like the 6502, and unlike the 65C02, the 65802 does not write to the stack during a reset.

Some of the enhancement of the 65C02 are available on the 65802 in the native mode, while in emulation mode the system behaves as a 6502. R/W' is low during the modify cycle of read-modify-write cycles in the emulation mode; high in the native mode.

## 65816 Signals

Most of the signals behave as on the 65802, with the following additions and changes:

## Western Design Center

### Bank Address

The most important difference on the 65816 is the multiplexing of the bank address (**BA0-BA7**) with the data pins (**D0-D7**). During phase two low, the bank address is valid; during phase two high, data is read or written on the same pins. The bank address must be latched during phase one to provide a valid twenty-four bit address when concatenated with **A0-A15**.

### Vector Pull

The **VP** signal is asserted whenever any of the vector addresses (\$00:FFE4-FFEF, \$00:FFF4-FFFF) are being accessed as part of an interrupt-type service cycle. This lets external hardware modify the interrupt vector, eliminating the need for software polling for interrupt sources.

### Abort

The **ABORT** input pin, when it is asserted, causes the current instruction to be aborted. Unlike an interrupt, none of the registers are updated and the instruction quits execution from the cycle where the **ABORT** signal was received. No registers are modified. In other words, the processor is left in the state it was in before the instruction that was aborted. Control is shifted to the **ABORT** vector after an interrupt-like context-saving cycle.

The **ABORT** signal lets external hardware abort instructions on the basis of undesirable address bus conditions; memory protection and page virtual memory systems can be fully implemented using this signal.

**ABORT** should be held low for only one cycle; if held low during the **ABORT** interrupt sequence, the **ABORT** interrupt will be aborted.

### Valid Program Address and Valid Data Address

The **VPA** and **VDA** signals extend the concept of the **SYNC** signal. Together, these two pins encode one of four possible internal processor states, based on the type of memory being accessed:

VPA	VDA	
0	0	-Internal operation
0	1	-Valid program address
1	0	-Valid data address
1	1	-Opcode fetch

During internal operations, the output buffers may be disabled by external logic, making address bus available for transparent direct memory access. Also, since the 65816 sometimes generates a false read during instructions that cross page boundaries, these may be trapped via these two signals if this is desirable. Note, however, that addresses should not be qualified in emulation mode if hardware such as the Apple II disk controller is used, which requires false read to operate.

The other states may be used for virtual memory implementation and high-speed data or instruction cache control. **VPA** and **VDA** high together are equivalent to the 6502 **SYNC** output.

### Memory and Index

These two signals are multiplexed on pin 38. **M** is available during phase zero, **X** during phase one. These signals reflect the contents of the status register **m** and **x** flags, allowing (along with **E** described below) external logic to fully decode opcode fetches.

As a mask option, the 65816 may be specified with the 6502 **SET OVERFLOW** signal instead of the **M/X** signal.

**M** and **X** are invalid for the instruction cycle following the **REP**, **SEP**, and **PLP** instruction execution; this cycle is the opcode fetch cycle of the next instruction.

## Western Design Center

### **Emulation**

The **E** signal reflects the state of the processor's **e** flag; depending on whether or not the processor is in emulation mode or not, external system compatibility feature (such as memory mapping or system speed) could be enabled or disabled.

### **Bus Enable**

This signal replaces the data bus enable signal of the 6502; when asserted, it disables the address buffers and R/W' as well as the data buffers

## B. 65x Series Support Chips

There are a plethora of companion chips for the 65x processors. The ones every assembly language programmer runs into eventually are serial and parallel input/output (I/O) chips. The 65x family serial I/O controller is the 6551 Asynchronous Communication Interface Adapter (ACIA), while the simplest parallel I/O controller is the 6521 Peripheral Interface Adapter (PIA).

As the architecture section of this book has already noted, the 65x microprocessors have memory-mapped I/O, not special I/O opcodes. That is, they assign each input and each output device one or more memory locations. An output device's status registers can be tested to determine if the device is ready to send a unit of data. Conversely, an input device's status registers can be tested to determine if a unit of data has arrived and can be read. Writing data is accomplished by storing it to one of the output device's memory locations; reading it is accomplished with a load-register instruction, with its operand one of the input device's memory locations.

One caution: Don't attempt to use *any* peripheral chips without calling or writing the chip's manufacturer for a data sheet, usually provided for little or no charge. While data sheets are no joy to read, they contain enough information to sooner or later explain the programming problems you will run into, if not on your current project, then on the next one.

### The 6551 Serial Chip

You may already be familiar with the 6551 ACIA. There is one controlling the serial port on every Apple II c, and one on the plug-in Apple II e Super Serial Card.

The 6551 features an on-chip baud-rate generator, which lets your program set any of fifteen baud rates from 50 to 19,200. Like most other serial chips, word length, number of stop bits, and parity bit generation and detection can also be set under program control.

As an example, if the Super Serial Card were located, as it commonly is, in the Apple IIe's port two, four consecutive memory locations are allocated to the 6551 beginning at \$C0A8. The 6551's Transmit/Receive Data Register is located at \$C0A8. The current status of the chip (for example, indicating it has received a byte of data) is indicated in the Status Register, located at \$C0A9 (*see* Figure B.1). Two registers are used to initialize the chip. The Command Register, located at \$C0AA, is used to set up parity and several other parameters. As Figure B.2 indicates, writing \$0B to the Command Register sets up a commonly used set of parameters – no parity, and both the **RTS** and the **DTR** lines enabled. The Control Register, located at \$C0AB, is used to set up stop bits, word length, and baud rate; as Figure B.3 indicates, writing \$1E to the Control Register sets up a commonly used set of parameters – one stop bit, eight-bit data, and communications running at 9600 baud.

So the 6551 is initialized by the 65816 code shown in Fragment B.1.

0000	COMPORT	GEQU	\$C0A8	6551 located at \$C0A8, 9, A, B
0000				
0000	E220	SEP	#\$20	use 8-bit accumulator
0002		LONGA	OFF	
0002				
0002	A900	LDA	#0	
0004	8DA9C0	STA	COMPORT+1	StatusReg: programmed reset first
0007	A91E	LDA	#\$1E	
0009	8DABC0	STA	COMPORT+3	CtrlReg: 1 stop bit/8-bit data/960
000C	A90B	LDA	#\$0B	
000E	8DAAC0	STA	COMPORT+2	CmdReg: no parity/RTS, DTR enabled
0011	60	RTS		

**Fragment B.1**

Actually, *any* value can be written to the status register to cause a programmed reset; this operation is done to reinitialize the I/O registers – the three figures each show the effects on the non-data registers on each of their status bits.



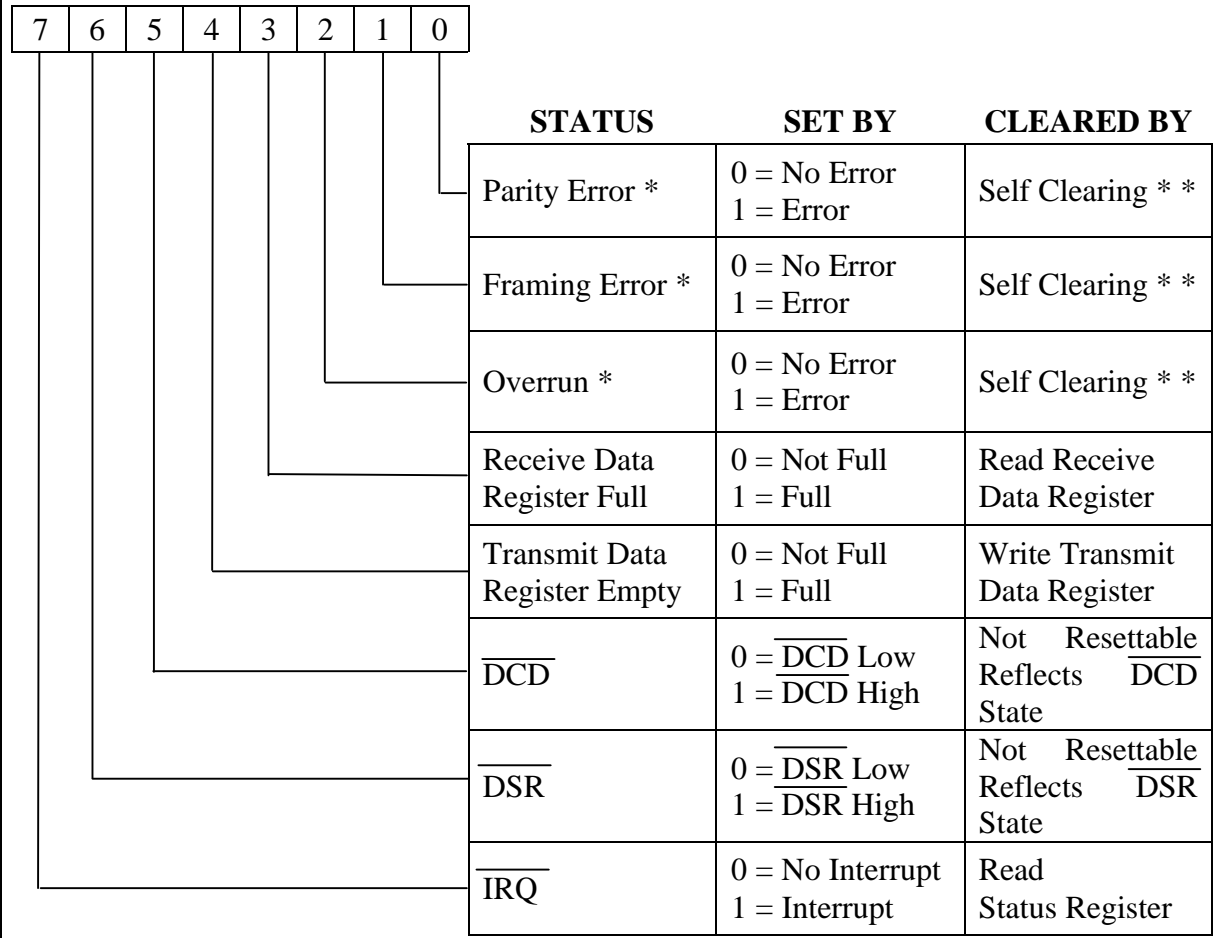

\*NO INTERRUPT GENERATED FOR THESE CONDITIONS

\*\*CLEARED AUTOMATICALLY AFTER A READ OF RDR AND THE NEXT ERROR-FREE RECEIPT OF DATA

	7	6	5	4	3	2	1	0
HARDWARE RESET	0	-	-	1	0	0	0	0
PROGRAM RESET	-	-	-	-	-	0	-	-

Figure B-1. 6551 Status Register

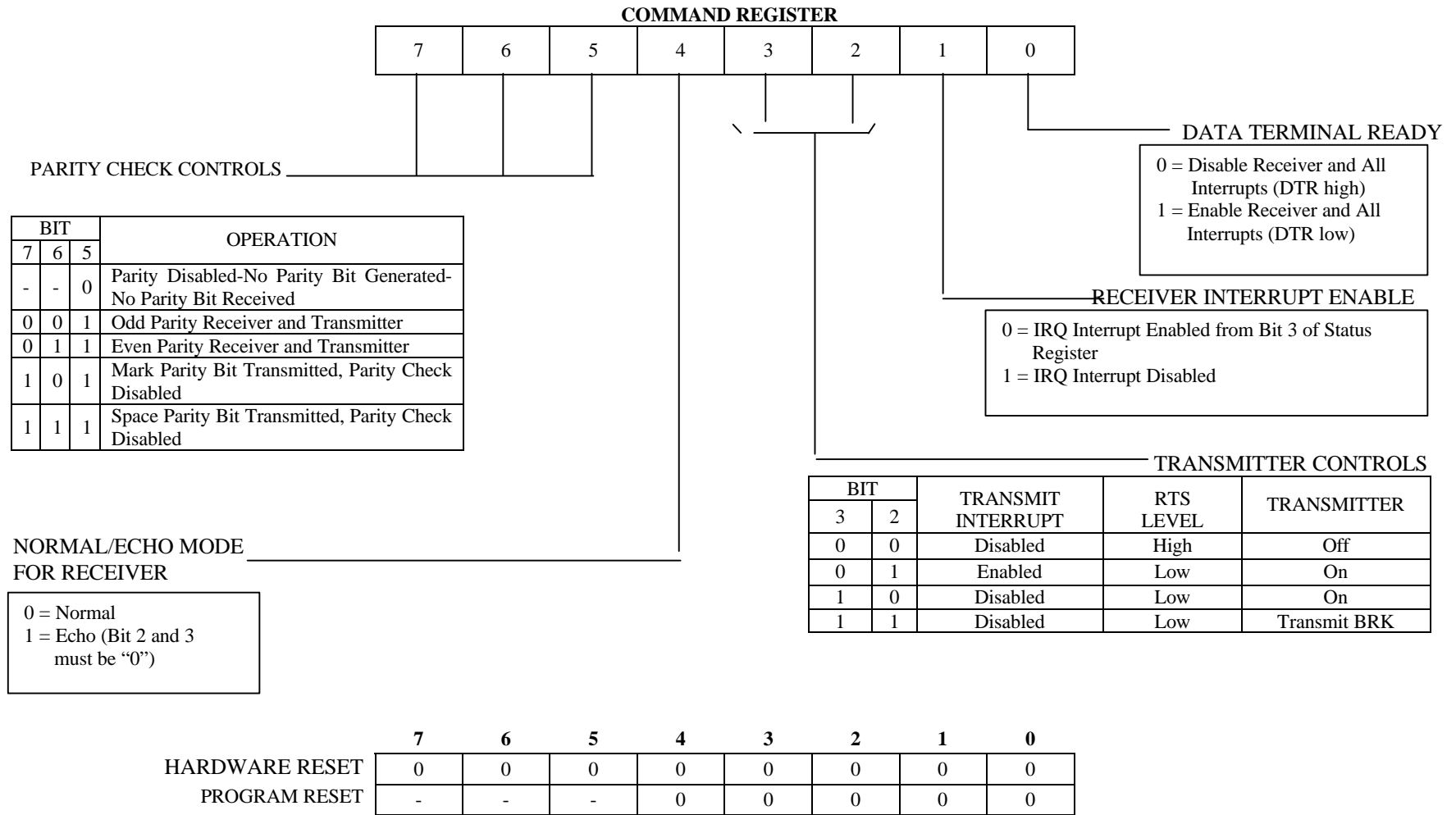

Figure B-2. 6551 Control Register

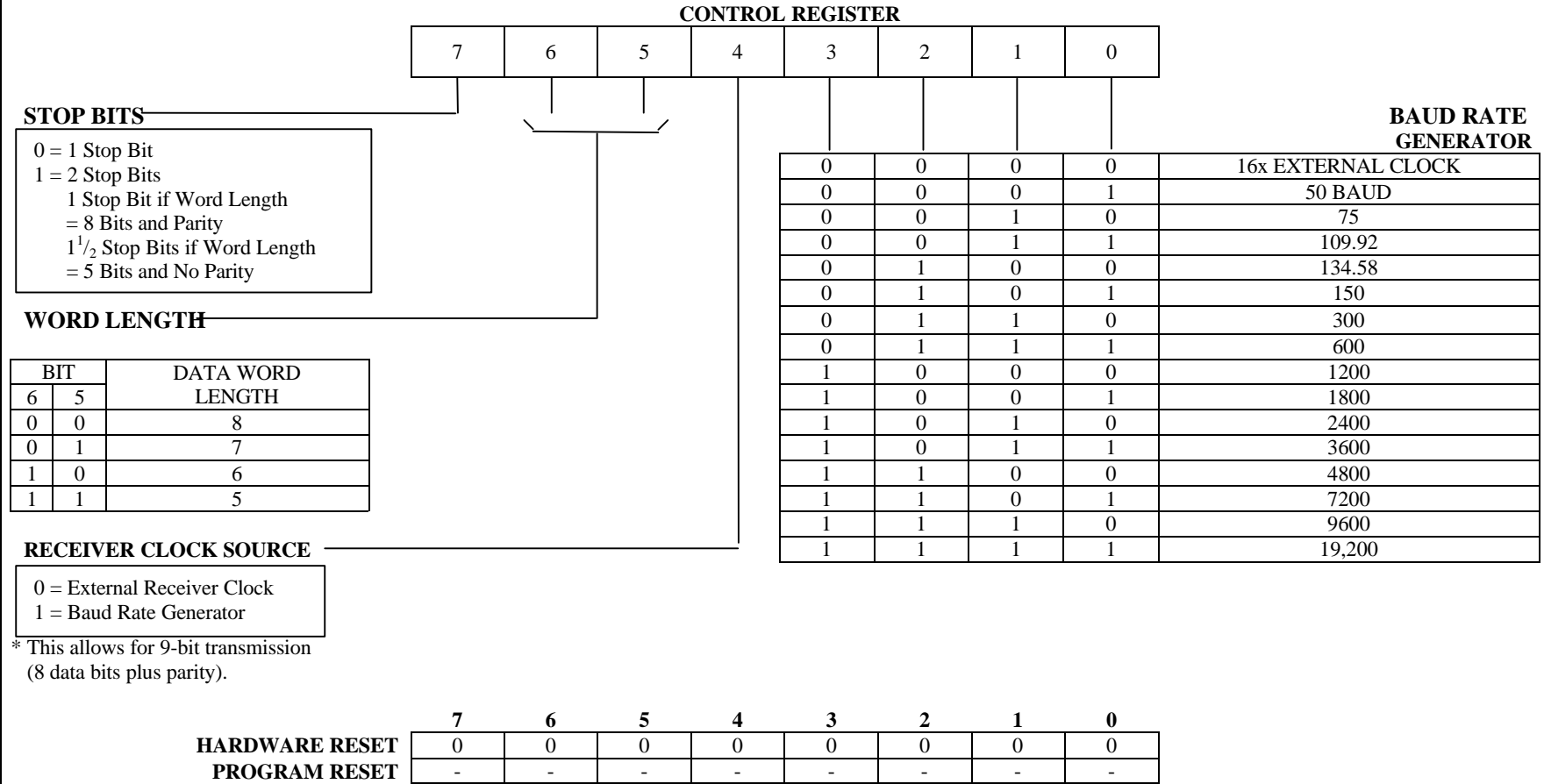

Figure B-3Control Register



## Western Design Center

When the 6551 connects a computer to a communications line—whether twisted-pair wire at 9600 baud or a modem at 300-baud—reading a byte from the communications line is a matter of (once the 6551 has initialized waiting until the status register bit three (receiver data register full) is set, then reading the byte from the data register, as shown in Fragment B.2.

0000					; code to read a byte from the communications line (6551)
0000					; returns byte in 8-bit A
0000					
0000		COMPORT	GEQU	\$C0A8	6551 located at \$C0A8,9,A,B
0000					
0000	E220		SEP	#\$20	use 8-bit accumulator
0002			LONGA	OFF	
0002					
0002	ADA9C0	AWAITCH	LDA	COMPORT+1	read Status Reg
0005	2908		AND	#8	single out bit 3 (revr data reg full)
0007	F0F9		BEQ	AWAITCH	loop until bit 3 set
0009					
0009	ADA8C0		LDA	COMPORT	read the byte from Receive Data Reg
000C	60		RTS		and return with it

**Fragment B.2**

Similarly, as Fragment B.3 shows, writing a byte out to the communications line is a matter of (once the 6551 has been initialized) waiting until the status register bit four (transmitter data register empty) is set, then writing the byte to the data register.

Neither routine does any error checking using the other status register bits.

## The 6521 Parallel Chip

The 6521 parallel I/O peripheral interface adapter is used to interface 65x microprocessors with printers, matrix-type keyboards, and other devices. It features two programmable eight-bit bidirectional parallel I/O ports (Ports A and B), any lines of which can be individually set for either reading or writing via a Data Direction Register. Provided all eight lines are set one way, you can either read or write a byte at a time (as opposed to a bit at a time via a serial chip) through the port. For fancy I/O, the 6521 has several “handshake” lines for greater control of I/O.

Like the 6551, the 6521 occupies four address locations (those dependent on the hardwiring of the two Register Select lines). But it has six registers, three for each port: a control register, a data register, and a data direct register. Each port’s data register and data direction register are addressed at the same location. Bit two of the port’s control register determines which register is connected to that address at any one time: if control register bit two is set, the data register is connected; if control register bit two is clear, the data direction register is connected.

0000					; routine to write a byte to the communications line (6551)
0000					; enter with byte in 8-bit A
0000					
0000		COMPORT	GEQU	\$C0A8	6551 located at \$C0A8,9,A,B
0000					
0000	48		PHA		save byte to write; free accum
0001					
0001	ADA9C0	WAITRDY	LDA	COMPORT+1	read Status Reg
0004	291000		AND	#\$10	get bit 4 (trnsmt data reg empty)
0007	F0F8		BEQ	WAITRDY	loop until bit 4 set
0009					
0009	68		PLA		retrieve byte to write
000A	8DA8C0		STA	COMPORT	write the byte to Transmit Data Reg
000D	60		RTS		

**Fragment B.3**

The data direction register is generally initialized for an application just once; then the data register is selected. Each data direction register bit controls the same-numbered bit in the data register: if a data direction register bit is set, the corresponding data register bit becomes an output line; if a data direction register bit is clear, the corresponding data register bit becomes an input line.

## Western Design Center

Imagine an application in which a printer is wired through a Centronics-compatible printer port to a 6521's port A: the 6521's eight Port A bits are connected to Centronics pins two through none. Port B is used to control the interface between computer and printer: the 6521's Port B bit zero is connected to the printer's Data Strobe (Centronics pin one); the 6521's Port B bit seven is connected to the printer Busy Line (Centronics pin 11).

The 6521 PIA is automatically initialed on power-up and reset to all be inputs (all registers are cleared). So every program should initialize all the lines it will use, either as inputs or as outputs, every time it is run. In the case, setting up output to the printer means al of Port A needs to be set up as inputs, while Port B bit zero must be initialized as an output and bit seven as an input. Setting up the rest of Port B as inputs is a good habit to protect peripherals, as seen in Fragment B.4.

0000	E220	SEP	#\$20	use 8-bit accumulator
0002		LONGA	OFF	
0002				
0002				; set up Port A as entirely output
0002				
0002	AD0080	LDA	PORTACTRL	get byte in Port A Control Reg
0005	29FB	AND	##%11111011	clear bit 2: select Data Direction Reg
0007	8D0080	STA	PORTACTRL	and store it back
000A				
000A	A9FF	LDA	#\$FF	
000C	8D0080	STA	PORTA	store all 1's to make Port A an output
000F				
000F	AD0080	LDA	PORTACTRL	get byte in Port A Control Reg
0012	0904	ORA	##%00000100	set bit 2: select Data Reg
0014	8D0080	STA	PORTACTRL	and store it back
0017				
0017				; set up Port B: bit 0 as output; bit 7 as input
0017				
0017	AD0080	LDA	PORTBCTRL	get byte in Port B Control Reg
001A	29FB	AND	##%11111011	clear bit 2: select Data Direction Reg
001C	8D0080	STA	PORTBCTRL	and store it back
001F				
001F	A901	LDA	#1	
0021	8D0080	STA	PORTB	store 1 to bit 0 (output); 0 to bit 7
0024				
0024	AD0080	LDA	PORTBCTRL	get byte in Port B Control Reg
0027	0904	ORA	##%00000100	set bit 2: select Data Reg
0029	8D0080	STA	PORTBCTRL	and store it back
002C				
002C	A901	LDA	#1	write 1 to printer's Data Strobe
002E	8D0080	STA	PORTB	to initialize Data Strobe to 1 (high)
0031				
0031	60	RTS		

### Fragment B.4

**PORTACTRL**, **PORTA**, **PORTBCTRL**, and **PORTB** must be elsewhere equated to the addresses at which each is located. The value in the control register is loaded and bit two is ANDed out with the mask, then stored back to choose the data direction register as the chosen register in each port. All ones are stored to Port A's data direction register, selecting all eight lines as outputs. One is stored to Port B's data direction register, selecting bit zero as an output and the rest of the port as inputs. Then the control registers are loaded again, this time ORing bit two back on before re-storing them, to choose the data register as the chosen register in each port. Finally, one is written out Port B to the printer's Data Strobe to initialize the line.

Now bytes can be written to the printer by waiting for a zero on the Printer Busy Line (bit seven of Port B was chosen so that a positive/negative test could be made to test the nit), then storing the byte to be written to Port A, and finally toggling the Data Strobe to zero and then back to one to inform the printer that a new character is ready to be printed.

## Western Design Center

0000					; write character in eight-bit accumulator to the printer
0000					
0000	2C0080	POUT	BIT	PORTB	move Port B bit 7 (Busy Line) to n flag
0003	30FB		BMI	POUT	wait until printer is not busy
0005					
0005	8D0080		STA	PORTA	write char in accum to printer
0008					
0008	A90000		LDA	#0	tell the printer to get and print it:
000B	8D0080		STA	PORTB	strobe the printer: write a 0 to bit 0
000E	EA		NOP		allow a wait cycle
000F	A90100		LDA	#1	
0012	8D0080		STA	PORTB	then toggle Strobe back to high (normal)
0015					
0015	60		RTS		

### Fragment B.5

You must be sure, in toggling the Strobe by writing to it, that the zero written to bit seven (zeroes are written to bits one through seven during both writes to Port B) not be read back as though it is a value being sent by the printer's Busy Line indicating the printer is not busy.

Remember that it is always important to have a data sheet for each peripheral support chip you attempt to write code for.

## C. The Rockwell 65C02

Rockwell International Corporation has a family of CPUs which it calls the R65C00 family. It includes their R65C02; while the designation would lead you to believe it is the 65C02 to which a part of this book is devoted, in fact its instruction set is a superset of the 65C02 instruction set discussed earlier. It is the 65C02 described earlier, not the Rockwell part, which Apple employed in its IIc computer and the 1985 upgrade to its IIe computer.

Furthermore, the R65C02's superset adds 32 instructions with opcodes that are the same as 32 very different instructions on the 65816, making the Rockwell R65C02 incompatible with the 65802 and 65816. For this reason, the R65C02 has been regulated to this appendix. If these additional instructions are disregarded and left unused, the remaining available instructions correspond to the standard 65C02 instruction set.

This is not to say the additional instructions are without merit. Rockwell's R65C02 has two additional operations for manipulating a single zero page bit at a time, Reset Memory Bit (**RMB**) and Set Memory Bit (**SMB**), and two additional operations for testing a single zero page bit and branching if it is clear or set, Branch on Bit Reset (**BBR**) and Branch on Bit Set (**BBS**). All four have eight versions – one for each bit – which are specified by adding a bit number (0 through 7) to the mnemonic. So there are 32 total additional instructions.

The operand to the bit-manipulating instructions is a zero page address (specified as **dp**, for “direct page”, in the following pages to be consistent with the instructions chapter, although the direct page is actually limited to the zero page). The operand to the bit-testing instructions is a compound operand: a zero page address to test, a comma, and a nearby label to which to branch (which an assembler turns into a program counter relative offset).

While incompatible with the 65802/65816 family expansion, the Rockwell 65C02's bit manipulation and testing instructions can be valuable for control applications, in which single bits are used to store boolean true/false values and to send signals to external devices.



**BBR****Branch on Bit Reset**

The specified bit in the zero page location specified in the operand is tested. If it is clear (reset), a branch is taken; if it is set, the instruction immediately following the two-byte **BBRx** instruction is executed. The bit is specified by a number (0 through 7) concatenated to the end of the mnemonic.

If the branch is performed, the third byte of the instruction is used as a signed displacement from the program counter; that is, it is added to the program counter: a positive value (numbers less than or equal to \$80; that is, numbers with the high-order bit clear) results in a branch to a higher location; a negative value (greater than \$80, with the high-order bit set) results in a branch to a lower location. Once the branch address is calculated, the result is loaded into the program counter, transferring control to that location.

Most assemblers calculate the displacement for you: you must specify as the operand, not the displacement but rather the label to which you wish to branch. The assembler then calculates the correct offset.

Flags Affected: - - - - -

**Codes:**

<i>Addressing Modes:</i>	<i>Syntax</i>	<b>Opcode</b> <i>(hex)</i>	<i>Available to:</i>				<i># of</i> Bytes	<i># of</i> Cycles
			<i>6502</i>	<i>65C02</i>	<i>R65C02</i>	<i>65802</i>		
Direct Page / Program Counter Relative	BBR0 <i>dp, nearlabel</i>	0F			x		3	5
Direct Page / Program Counter Relative	BBR1 <i>dp, nearlabel</i>	1F			x		3	5
Direct Page / Program Counter Relative	BBR2 <i>dp, nearlabel</i>	2F			x		3	5
Direct Page / Program Counter Relative	BBR3 <i>dp, nearlabel</i>	3F			x		3	5
Direct Page / Program Counter Relative	BBR4 <i>dp, nearlabel</i>	4F			x		3	5
Direct Page / Program Counter Relative	BBR5 <i>dp, nearlabel</i>	5F			x		3	5
Direct Page / Program Counter Relative	BBR6 <i>dp, nearlabel</i>	6F			x		3	5
Direct Page / Program Counter Relative	BBR7 <i>dp, nearlabel</i>	7F			x		3	5

**BBS****Branch on Bit Set**

The specified bit in the zero page location specified in the operand is tested. If it is set, a branch is taken; if it is clear (reset), the instructions immediately following the two-byte **BBSx** instruction is executed. The bit is specified by a number (0 through 7) concatenated to the end of the mnemonic.

If the branch is performed, the third byte of the instruction is used as a signed displacement from the program counter; that is, it is added to the program counter: a positive value (numbers less than or equal to \$80; that is, numbers with the high order bit clear) results in a branch to a higher location; a negative value (greater than \$80, with the high-order bit set) results in a branch to a lower location. Once the branch address is calculated, the result is loaded into the program counter, transferring control to that location.

Most assemblers calculate the displacement for you: you must specify as the operand, not the displacement but rather the label to which you wish to branch. The assembler then calculates the correct offset.

Flags Affected: d - - - - -

**Codes:**

Addressing Mode	Syntax	Opcode (hex)	Available to :				# of Bytes	# of cycles
			6502	65C02	R65C02	65802		
Direct Page / Program Counter Relative	BBS0 <i>dp, nearlabel</i>	8F			x		3	5
Direct Page / Program Counter Relative	BBS1 <i>dp, nearlabel</i>	9F			x		3	5
Direct Page / Program Counter Relative	BBS2 <i>dp, nearlabel</i>	AF			x		3	5
Direct Page / Program Counter Relative	BBS3 <i>dp, nearlabel</i>	BF			x		3	5
Direct Page / Program Counter Relative	BBS4 <i>dp, nearlabel</i>	CF			x		3	5
Direct Page / Program Counter Relative	BBS5 <i>dp, nearlabel</i>	DF			x		3	5
Direct Page / Program Counter Relative	BBS6 <i>dp, nearlabel</i>	EF			x		3	5
Direct Page / Program Counter Relative	BBS7 <i>dp, nearlabel</i>	FF			x		3	5

## Western Design Center

### RMB

### Reset Memory Bit

Clear the specified bit in the zero page memory location specified in the operand. The bit to clear is specified by a number (0 through 7) concatenated to the end of the mnemonic.

**Flags Affected:** - - - - -

### Codes:

<i>Addressing Mode</i>	<i>Syntax</i>	Opcode ( <i>hex</i> )	<i>Available to:</i>				<i># of Bytes</i>	<i># of Cycles</i>
			<i>6502</i>	<i>65C02</i>	<i>R65C02</i>	<i>65802</i>		
Direct Page	RMB0 <i>dp</i>	07			x		2	5
Direct Page	RMB1 <i>dp</i>	17			x		2	5
Direct Page	RMB2 <i>dp</i>	27			x		2	5
Direct Page	RMB3 <i>dp</i>	37			x		2	5
Direct Page	RMB4 <i>dp</i>	47			x		2	5
Direct Page	RMB5 <i>dp</i>	57			x		2	5
Direct Page	RMB6 <i>dp</i>	67			x		2	5
Direct Page	RMB7 <i>dp</i>	77			x		2	5

**SMB**

**Set Memory Bit**

Set the specified bit in the zero page memory location specified in the operand. The bit to set is specified by a number (0 through 7) concatenated to the end of the mnemonic.

**Flags Affected:** - - - - -

**Codes:**

<i>Addressing Mode</i>	<i>Syntax</i>	<i>Opcode (hex)</i>	<i>Available to:</i>				<i># of Bytes</i>	<i># of Cycles</i>
			<i>6502</i>	<i>65C02</i>	<i>R65C02</i>	<i>65802</i>		
Direct Page	SMB0 <i>dp</i>	87			x		2	5
Direct Page	SMB1 <i>dp</i>	97			x		2	5
Direct Page	SMB2 <i>dp</i>	A7			x		2	5
Direct Page	SMB3 <i>dp</i>	B7			x		2	5
Direct Page	SMB4 <i>dp</i>	C7			x		2	5
Direct Page	SMB5 <i>dp</i>	D7			x		2	5
Direct Page	SMB6 <i>dp</i>	E7			x		2	5
Direct Page	SMB7 <i>dp</i>	F7			x		2	5

## D. Instruction Groups

The 65x instructions can be divided into three groups, on the basis of both the types of actions of each instruction and the addressing modes each can use. The opcodes in the first group and some in the second have similar bit patterns, the same addressing modes available, and regularity which can make remembering the capabilities of a particular instruction – or creating a compiler generator – much easier.

Group I instructions are the most commonly used load, store, logic, and arithmetic instructions, and have by far the most addressing modes available to them. Group II instructions are mostly **read-modify-write** instructions, such as increment, decrement, shift, and rotate, which both access and change one and only one register or memory location.

Group III is a catch-all for the remaining instructions, such as index register comparisons and stack operations.

### Group I Instructions

The 65x Group I instructions, with their opcode's bit patterns, are shown in Table D.1. The 'aaaa's are filled with addressing mode bit patterns – there is one pattern for each addressing mode available to Group I instruction.

Add with Carry to the Accumulator (ADC)	011a	aaaa
And the Accumulator (AND)	001a	aaaa
Compare the Accumulator (CMP)	110a	aaaa
Exclusive Or the Accumulator (EOR)	010a	aaaa
Load the Accumulator (LDA)	101a	aaaa
Or the Accumulator (ORA)	000a	aaaa
Subtract with Borrow from the Accumulator (SBC)	111a	aaaa
Store the Accumulator (STA)	100a	aaaa

**Table D-1 Group I Instructions Opcode Patterns**

The 6502 addressing modes available to the Group I instructions have bit patterns that all end in '01'. These bit patterns are found in Table D.2. The exception to this scheme is **STA** immediate; since it is not possible to use immediate addressing with a store instruction, its logical opcode 1000 1001 is used by a non-Group-I instruction.

Immediate	0	1001
Direct (Zero) Page	0	0101
Absolute	0	1101
Direct (Zero) Page Indexed by X	1	0101
Absolute Indexed by X	1	1101
Absolute Indexed by Y	1	1001
Direct (Zero) Page Indexed Indirect with X (pre-indexed)	0	0001
Direct (Zero) Page Indirect Indexed with Y (post-indexed)	1	0001

**Table D-2 Address Mode Patterns for Group I Instructions**

The 65C02 adds one more addressing mode for Group I instructions; it has the only Group I addressing mode bit pattern to end in a zero:

Direct (Zero) Page Indirect 10010

The 65802 and 65816 add the six addressing modes for Group I instructions found in Table D.3.

Direct Page Indirect Long Indexed with Y (post-indexed long)	1	0111
Direct Page Indirect Long	0	0111
Absolute Long	0	1111
Absolute Long Indexed with X	1	1111
Stack Relative	0	0011
Stack Relative Indirect Indexed with Y	1	0011

**Table D-3 65802/65816 Group I Addressing Mode Patterns**

## Group II Instructions

Group II instructions are an amalgam of mostly read-modify-write instructions with very similar addressing modes (differing only whether they have accumulator addressing to them on the 6502). The instructions, with their opcode bit patterns, are listing in Table D.4.

There are either four or five addressing modes available to these instructions on the 6502 – five if the missing bits are ‘bbc’ rather than just ‘bb’, the fifth addressing mode being accumulator addressing.

Table D.5 shows the five addressing modes with their bit patterns. All three bits in this table are filled into the ‘bbc’ missing bits in Table D.4; only the first two bits of each Table D.5 set are filled into ‘bb’ missing bits in Table D.4.

Arithmetic Shift Left (ASL)	000b	bc10
Decrement (DEC)	110b	b110
Increment (INC)	111b	b110
Logical Shift Right (LSR)	010b	bc10
Rotate Left through Carry (ROL)	001b	bc10
Rotate Right through Carry (ROR)	011b	bc10
Store Index Register X (STX)	100b	b110
Store Index Register Y (STY)	100b	b100

**Table D-4 Group II Opcode Patterns**

Accumulator	0	10
Direct (Zero) Page	0	01
Absolute	0	11
Direct (Zero) Page Indexed by X	1	01
Absolute Indexed by X	1	11

**Table D-5 Address Mode Patterns for Group II Instruction**

Notice how the four ‘bb1’ addressing modes have the same bit patterns as the first three bits of their corresponding bit patterns for the Group I instruction addressing mode.

There are a few exceptions.

Absolute indexing is not available for storing either index register. Furthermore, since the register cannot use itself, the **STX** instruction can’t use direct page, X; instead, direct page, Y substitutes for this instruction’s direct page, indexed store.

The two 65C02 instructions to increment and decrement the accumulator do not follow this scheme at all; giving these instructions that addressing mode clearly was not planned when the 6502 was designed, since their opcodes were assigned to other instructions. Nor does the 65C02’s **STZ** (store zero memory) instruction, which uses the main four addressing modes, follow the scheme, even though it seems clearly to be a Group II instruction of this type. But four of the five addressing modes of the **BIT** instruction on the 65C02, 65802, and 65816 (the 6502 has only two addressing modes for this instruction)-the four ‘bb1’ addressing modes above-follow this scheme (its bit pattern is 001b b100). It also has an immediate addressing mode, however, which is in no way regular.

## Western Design Center

### Loading the Index Registers

The two index registers can be loaded with regular opcodes:

Load Index Register X (LDX)	101d	dd10
Load Index Register Y (LDY)	101d	dd00

Available to them are the five addressing modes in table D.6.

Immediate	0	00
Direct Page	0	01
Absolute	0	11
Direct Page Indexed	1	01
Absolute Indexed	1	11

**Table D-6 Address Mode Patterns for Load Index Register Instruction**

The two indexed modes use the Y index register for indexing when loading the X register and vice versa.

### Index Register Compares

The two instructions to compare an index register to memory have three addressing modes available to them. The instructions are:

Compare Index Register X with Memory (CPX)	1110	ee00
Compare Index Register Y with Memory (CPY)	1100	ee00

Table D.7 lists the three addressing modes available.

Immediate	00
Direct Page	01
Absolute	11

**Table D-7 Address Mode Patterns for Compare Index Register Instructions**

### Test-and-Change-Bits Instructions

The two test-and-change-bits instructions each have two addressing modes that they use in a regular manner. The two instructions are:

Test and Reset Memory Bits (TRB)	0001	x100
Test and Set Memory Bits (TSB)	0000	x100

The two addressing modes are:

Direct Page	x = 0
Absolute	x = 1

# E. The ASCII Character Set

Low Bit Set:		High Bit Set:		Character	Names
Decimal	Hex	Decimal	Hex		
0	00	128	80	Control-@	NUL, null
1	01	129	81	Control-A	
2	02	130	82	Control-B	
3	03	131	83	Control-C	Break
4	04	132	84	Control-D	
5	05	133	85	Control-E	
6	06	134	86	Control-F	
7	07	135	87	Control-G	BEL, bell
8	08	136	88	Control-H	BS, backspace
9	09	137	89	Control-I	HT, horizontal tab
10	0A	138	8A	Control-J	LF, line feed
11	0B	139	8B	Control-K	VT, vertical tab
12	0C	140	8C	Control-L	FF, form feed, Page
13	0D	141	8D	Control-M	CR, carriage return
14	0E	142	8E	Control-N	
15	0F	143	8F	Control-O	
16	10	144	90	Control-P	
17	11	145	91	Control-Q	XON, resume
18	12	146	92	Control-R	
19	13	147	93	Control-S	XOFF, screen pause
20	14	148	94	Control-T	
21	15	149	95	Control-U	
22	16	150	96	Control-V	
23	17	151	97	Control-W	
24	18	152	98	Control-X	CAN, cancel line
25	19	153	99	Control-Y	
26	1A	154	9A	Control-Z	End of file
27	1B	155	9B	Control-[	ESC, escape
28	1C	156	9C	Control-\	
29	1D	157	9D	Control-]	
30	1E	158	9E	Control-^	
31	1F	159	9F	Control-_	
32	20	160	A0		Space
33	21	161	A1	!	Exclamation point
34	22	162	A2	"	Quote
35	23	163	A3	#	Pound sign
36	24	164	A4	\$	Dollar sign
37	25	165	A5	%	Percent sign
38	26	166	A6	&	Ampersand
39	27	167	A7	'	Apostrophe
40	28	168	A8	(	Left parenthesis
41	29	169	A9	)	Right parenthesis
42	2A	170	AA	*	Asterisk
43	2B	171	AB	+	Plus sign
44	2C	172	AC	,	Comma
45	2D	173	AD	-	Minus sign, dash
46	2E	174	AE	.	Period
47	2F	175	AF	\	Backlash
48	30	176	B0	0	
49	31	177	B1	1	
50	32	178	B2	2	
51	33	179	B3	3	
52	34	180	B4	4	
53	35	181	B5	5	
54	36	182	B6	6	



## Western Design Center

Low Bit Set:		High Bit Set:		Character	Names
Decimal	Hex	Decimal	Hex		
55	37	183	B7	7	
56	38	184	B8	8	
57	39	185	B9	9	
58	3A	186	BA	:	Colon
59	3B	187	BB	;	Semicolon
60	3C	188	BC	<	Less than
61	3D	189	BD	=	Equal
62	3E	190	BE	>	Greater than
63	3F	191	BF	?	Question mark
64	40	192	C0	@	At sign
65	41	193	C1	A	
66	42	194	C2	B	
67	43	195	C3	C	
68	44	196	C4	D	
69	45	197	C5	E	
70	46	198	C6	F	
71	47	199	C7	G	
72	48	200	C8	H	
73	49	201	C9	I	
74	4A	202	CA	J	
75	4B	203	CB	K	
76	4C	204	CC	L	
77	4D	205	CD	M	
78	4E	206	CE	N	
79	4F	207	CF	O	
80	50	208	D0	P	
81	51	209	D1	Q	
82	52	210	D2	R	
83	53	211	D3	S	
84	54	212	D4	T	
85	55	213	D5	U	
86	56	214	D6	V	
87	57	215	D7	W	
88	58	216	D8	X	
89	59	217	D9	Y	
90	5A	218	DA	Z	
91	5B	219	DB	[	Left bracket
92	5C	220	DC	\	Backlash
93	5D	221	DD	]	Right bracket
94	5E	222	DE	^	Caret
95	5F	223	DF	_	Underscore
96	60	224	E0	`	Accent grave
97	61	225	E1	a	
98	62	226	E2	b	
99	63	227	E3	c	
100	64	228	E4	d	
101	65	229	E5	e	
102	66	230	E6	f	
103	67	231	E7	g	
104	68	232	E8	h	
105	69	233	E9	i	
106	6A	234	EA	j	
107	6B	235	EB	k	
108	6C	236	EC	l	
109	6D	237	ED	m	

## Western Design Center

Low Bit Set:		High Bit Set:		Character	Names
Decimal	Hex	Decimal	Hex		
110	6E	238	EE	n	
111	6F	239	EF	o	
112	70	240	F0	p	
113	71	241	F1	q	
114	72	242	F2	r	
115	73	243	F3	s	
116	74	244	F4	t	
117	75	245	F5	u	
118	76	246	F6	v	
119	77	247	F7	w	
120	78	248	F8	x	
121	79	249	F9	y	
122	7A	250	FA	z	
123	7B	251	FB	{	Left brace
124	7C	252	FC		Vertical line
125	7D	253	FD	}	Right brace
126	7E	254	FE	~	Tilde
127	7F	255	FF	DEL	delete, rubout

## Western Design Center

Low Bit Set:		High Bit Set:			
Decimal	Hex	Decimal	Hex	Character	Names
0	00	128	80	Control-@	NUL, null
1	01	129	81	Control-A	
2	02	130	82	Control-B	
3	03	131	83	Control-C	Break
4	04	132	84	Control-D	
5	05	133	85	Control-E	
6	06	134	86	Control-F	
7	07	135	87	Control-G	BEL, bell
8	08	136	88	Control-H	BS, backspace
9	09	137	89	Control-I	HT, horizontal tab
10	0A	138	8A	Control-J	LF, line feed
11	0B	139	8B	Control-K	VT, vertical tab
12	0C	140	8C	Control-L	FF, form feed, Page
13	0D	141	8D	Control-M	CR, carriage return
14	0E	142	8E	Control-N	
15	0F	143	8F	Control-O	
16	10	144	90	Control-P	
17	11	145	91	Control-Q	XON, resume
18	12	146	92	Control-R	
19	13	147	93	Control-S	XOFF, screen pause
20	14	148	94	Control-T	
21	15	149	95	Control-U	
22	16	150	96	Control-V	
23	17	151	97	Control-W	
24	18	152	98	Control-X	CAN, cancel line
25	19	153	99	Control-Y	
26	1A	154	9A	Control-Z	End of file
27	1B	155	9B	Control-[	ESC, escape
28	1C	156	9C	Control-\	
29	1D	157	9D	Control-]	
30	1E	158	9E	Control-^	
31	1F	159	9F	Control-_	
32	20	160	A0		Space
33	21	161	A1	!	Exclamation point
34	22	162	A2	"	Quote
35	23	163	A3	#	Pound sign
36	24	164	A4	\$	Dollar sign
37	25	165	A5	%	Percent sign
38	26	166	A6	&	Ampersand
39	27	167	A7	'	Apostrophe
40	28	168	A8	(	Left parenthesis
41	29	169	A9	)	Right parenthesis
42	2A	170	AA	*	Asterisk
43	2B	171	AB	+	Plus sign
44	2C	172	AC	,	Comma
45	2D	173	AD	-	Minus sign, dash
46	2E	174	AE	.	Period
47	2F	175	AF	\	Backlash
48	30	176	B0	0	
49	31	177	B1	1	
50	32	178	B2	2	
51	33	179	B3	3	
52	34	180	B4	4	
53	35	181	B5	5	
54	36	182	B6	6	

## Western Design Center

Low Bit Set:		High Bit Set:		Character	Names
Decimal	Hex	Decimal	Hex		
55	37	183	B7	7	
56	38	184	B8	8	
57	39	185	B9	9	
58	3A	186	BA	:	Colon
59	3B	187	BB	;	Semicolon
60	3C	188	BC	<	Less than
61	3D	189	BD	=	Equal
62	3E	190	BE	>	Greater than
63	3F	191	BF	?	Question mark
64	40	192	C0	@	At sign
65	41	193	C1	A	
66	42	194	C2	B	
67	43	195	C3	C	
68	44	196	C4	D	
69	45	197	C5	E	
70	46	198	C6	F	
71	47	199	C7	G	
72	48	200	C8	H	
73	49	201	C9	I	
74	4A	202	CA	J	
75	4B	203	CB	K	
76	4C	204	CC	L	
77	4D	205	CD	M	
78	4E	206	CE	N	
79	4F	207	CF	O	
80	50	208	D0	P	
81	51	209	D1	Q	
82	52	210	D2	R	
83	53	211	D3	S	
84	54	212	D4	T	
85	55	213	D5	U	
86	56	214	D6	V	
87	57	215	D7	W	
88	58	216	D8	X	
89	59	217	D9	Y	
90	5A	218	DA	Z	
91	5B	219	DB	[	Left bracket
92	5C	220	DC	\	Backlash
93	5D	221	DD	]	Right bracket
94	5E	222	DE	^	Caret
95	5F	223	DF	_	Underscore
96	60	224	E0	`	Accent grave
97	61	225	E1	a	
98	62	226	E2	b	
99	63	227	E3	c	
100	64	228	E4	d	
101	65	229	E5	e	
102	66	230	E6	f	
103	67	231	E7	g	
104	68	232	E8	h	
105	69	233	E9	i	
106	6A	234	EA	j	
107	6B	235	EB	k	
108	6C	236	EC	l	
109	6D	237	ED	m	

## Western Design Center

Low Bit Set:		High Bit Set:		Character	Names
Decimal	Hex	Decimal	Hex		
110	6E	238	EE	n	
111	6F	239	EF	o	
112	70	240	F0	p	
113	71	241	F1	q	
114	72	242	F2	r	
115	73	243	F3	s	
116	74	244	F4	t	
117	75	245	F5	u	
118	76	246	F6	v	
119	77	247	F7	w	
120	78	248	F8	x	
121	79	249	F9	y	
122	7A	250	FA	z	
123	7B	251	FB	{	Left brace
124	7C	252	FC		Vertical line
125	7D	253	FD	}	Right brace
126	7E	254	FE	~	Tilde
127	7F	255	FF	DEL	delete, rubout